	E480232
---	----------------

Features

- Glass Passivated Chip
- Low Leakage
- Uni and Bidirectional Unit
- Excellent Clamping Capability
- Halogen Free Available Upon Request By Adding Suffix "-HF"
- Epoxy Meets UL 94 V-0 Flammability Rating
- For Bidirectional Devices Add "C" To The Suffix of The Part Number: i.e.P5KE5.0CA for 5% Tolerance

Mechanical Data

- Weight: 0.4 grams
- Case: Molded Plastic

Maximum Ratings

- For Capacitive Load, Derate Current by 20%
- Operating Junction Temperature Range: -65°C to +175°C
- Storage Temperature Range: -65°C to +175°C

Electrical Characteristics @ 25°C Unless Otherwise Specified

Peak Pulse Power Dissipation	P_{PPM}	500W	$T_A=25^{\circ}C$
Steady State Power Dissipation	$P_{M(AV)}$	1.0 W	$T_J=75^{\circ}C$

Device Marking:

Unidirectional - Type Number and Cathode Band
Bidirectional - Type Number Only

Pin Configuration



**500WATTS TVS
5.0 to 200 VOLTS**

DO-15

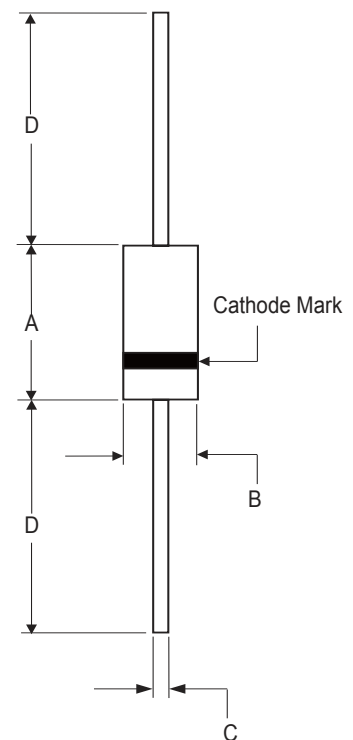

DIM	DIMENSIONS				NOTE
	INCHES		MM		
	MIN	MAX	MIN	MAX	
A	0.230	0.300	5.80	7.60	
B	0.104	0.140	2.60	3.60	
C	0.026	0.035	0.70	0.90	
D	1.000	-----	25.40	-----	

Electrical Characteristics @ 25°C Unless Otherwise Specified

MCC PART NUMBER	BREAKDOWN VOLTAGE V(BR) @ IT (VOLTS)		TEST CURRENT IT	RATED STANDOFF VOLTAGE VWM	MAXIMUM REVERSE LEAKAGE ID @VWM	MAXIMUM CLAMPING VOLTAGE VC @ IPP	MAXIMUM PEAK PULSE CURRENT IPP
	MIN	MAX	mADC	V	(μ A)	V	A
P5KE5.0	6.40	7.55	10	5.0	600	9.6	52.3
P5KE5.0A	6.40	7.25	10	5.0	600	9.2	54.3
P5KE6.0	6.67	8.45	10	6.0	600	11.4	43.9
P5KE6.0A	6.67	7.67	10	6.0	600	10.3	48.5
P5KE6.5	7.22	9.14	10	6.5	400	12.3	40.7
P5KE6.5A	7.22	8.30	10	6.5	400	11.2	44.7
P5KE7.0	7.78	9.86	10	7.0	150	13.3	37.8
P5KE7.0A	7.78	8.95	10	7.0	150	12.0	41.7
P5KE7.5	8.33	10.67	1	7.5	50	14.3	35.0
P5KE7.5A	8.33	9.58	1	7.5	50	12.9	38.8
P5KE8.0	8.89	11.30	1	8.0	25	15.0	33.3
P5KE8.0A	8.89	10.23	1	8.0	25	13.6	36.7
P5KE8.5	9.44	11.92	1	8.5	10	15.9	31.4
P5KE8.5A	9.44	10.82	1	8.5	10	14.4	34.7
P5KE9.0	10.0	12.6	1	9.0	5	16.9	29.5
P5KE9.0A	10.0	11.5	1	9.0	5	15.4	32.5
P5KE10	11.1	14.1	1	10	3	18.8	26.6
P5KE10A	11.1	12.8	1	10	3	17.0	29.4
P5KE11	12.2	15.4	1	11	3	20.1	24.9
P5KE11A	12.2	14.0	1	11	3	18.2	27.4
P5KE12	13.3	16.9	1	12	3	22.0	22.7
P5KE12A	13.3	15.3	1	12	3	19.9	25.1
P5KE13	14.4	18.2	1	13	3	23.8	21.0
P5KE13A	14.4	16.5	1	13	3	21.5	23.2
P5KE14	15.6	19.8	1	14	3	25.8	19.4
P5KE14A	15.6	17.9	1	14	3	23.2	21.5
P5KE15	16.7	21.1	1	15	3	26.9	18.8
P5KE15A	16.7	19.2	1	15	3	24.4	20.6
P5KE16	17.8	22.6	1	16	3	28.8	17.6
P5KE16A	17.8	20.5	1	16	3	26.0	19.2
P5KE17	18.9	23.9	1	17	3	30.5	16.4
P5KE17A	18.9	21.7	1	17	3	27.6	16.1
P5KE18	20.0	25.3	1	18	3	32.2	15.5
P5KE18A	20.0	23.3	1	18	3	29.2	17.2
P5KE20	22.2	28.1	1	20	3	35.8	13.9
P5KE20A	22.2	25.5	1	20	3	32.4	15.4
P5KE22	24.4	30.9	1	22	3	39.4	12.7
P5KE22A	24.4	28.0	1	22	3	35.5	14.1
P5KE24	26.7	33.8	1	24	3	43.0	11.6
P5KE24A	26.7	30.7	1	24	3	38.9	12.8
P5KE26	28.9	36.6	1	26	3	46.6	10.7
P5KE26A	28.9	33.2	1	26	3	42.1	11.9
P5KE28	31.1	39.4	1	28	3	50.0	9.9
P5KE28A	31.1	35.8	1	28	3	45.4	11.0

For parts without A, the VBR is +10%.

Electrical Characteristics @ 25°C Unless Otherwise Specified

MCC PART NUMBER	BREAKDOWN VOLTAGE V(BR) @ IT (VOLTS)		TEST CURRENT IT	RATED STANDOFF VOLTAGE VWM	MAXIMUM REVERSE LEAKAGE ID @VWM	MAXIMUM CLAMPING VOLTAGE VC @ IPP	MAXIMUM PEAK PULSE CURRENT IPP
	MIN	MAX	mADC	V	(μ A)	V	A
P5KE30	33.3	42.2	1	30	3	53.5	9.3
P5KE30A	33.3	38.3	1	30	3	48.4	10.3
P5KE33	36.7	46.5	1	33	3	59.0	5.8
P5KE33A	36.7	42.2	1	33	3	53.3	9.4
P5KE36	40.0	50.7	1	36	3	64.3	7.8
P5KE36A	40.0	46.0	1	36	3	58.1	8.6
P5KE40	44.4	56.3	1	40	3	71.4	7.0
P5KE40A	44.4	51.1	1	40	3	64.5	7.8
P5KE43	47.8	60.5	1	43	3	76.7	6.5
P5KE43A	47.8	54.9	1	43	3	69.4	7.2
P5KE45	50.0	63.3	1	45	3	80.3	6.2
P5KE45A	50.0	57.5	1	45	3	72.7	6.9
P5KE48	53.3	67.5	1	48	3	85.5	5.8
P5KE48A	53.3	61.3	1	48	3	77.4	6.5
P5KE51	56.7	71.8	1	51	3	91.1	5.5
P5KE51A	56.7	65.2	1	51	3	82.4	6.1
P5KE54	60.0	76.0	1	54	3	96.3	5.2
P5KE54A	60.0	69.0	1	54	3	87.1	5.7
P5KE58	64.4	81.6	1	58	3	103.0	4.9
P5KE58A	64.4	74.1	1	58	3	93.6	5.3
P5KE60	66.7	84.5	1	60	3	107.0	4.7
P5KE60A	66.7	76.7	1	60	3	96.8	5.2
P5KE64	71.1	90.1	1	64	3	114.0	4.4
P5KE64A	71.1	81.8	1	64	3	103.0	4.9
P5KE70	77.8	98.6	1	70	3	125.0	4.0
P5KE70A	77.8	89.5	1	70	3	113.0	4.4
P5KE75	83.3	105.7	1	75	3	134.0	3.7
P5KE75A	83.3	95.8	1	75	3	121.0	4.1
P5KE78	86.7	109.8	1	78	3	139	3.6
P5KE78A	86.7	99.7	1	78	3	126	4.0
P5KE85	94.4	119.2	1	85	3	151	3.3
P5KE85A	94.4	108.2	1	85	3	137	3.6
P5KE90	100	126.5	1	90	3	160	3.1
P5KE90A	100	115.5	1	90	3	146	3.4
P5KE100	111	141.0	1	100	3	179	2.8
P5KE100A	111	128.0	1	100	3	162	3.1
P5KE110	122	154.5	1	110	3	196	2.6
P5KE110A	122	140.5	1	110	3	177	2.8
P5KE120	133	169.0	1	120	3	214	2.3
P5KE120A	133	153.0	1	120	3	193	2.0
P5KE130	144	182.5	1	130	3	231	2.2
P5KE130A	144	165.5	1	130	3	209	2.4
P5KE150	167	211.5	1	150	3	268	1.9
P5KE150A	167	192.5	1	150	3	243	2.1
P5KE160	178	226.0	1	160	3	287	1.7

For parts without A, the VBR is +10%.

Electrical Characteristics @ 25°C Unless Otherwise Specified

MCC PART NUMBER	BREAKDOWN VOLTAGE V(BR) @ IT (VOLTS)		TEST CURRENT IT	RATED STANDOFF VOLTAGE VWM	MAXIMUM REVERSE LEAKAGE ID @VWM	MAXIMUM CLAMPING VOLTAGE VC @ IPP	MAXIMUM PEAK PULSE CURRENT IPP
	MIN	MAX	mADC	V	(μ A)	V	A
P5KE160A	178	205.0	1	160	3	259	1.9
P5KE170	189	239.5	1	170	3	304	1.6
P5KE170A	189	217.5	1	170	3	275	1.8
P5KE180	198	253.8	1	180	3	322	1.6
P5KE180A	198	230.4	1	180	3	292	1.7
P5KE190	209	267.9	1	190	3	340	1.5
P5KE190A	209	243.2	1	190	3	308	1.6
P5KE200	220	282.0	1	200	3	358	1.4
P5KE200A	220	256.0	1	200	3	324	1.5
P5KE5.0C	6.40	7.55	10	5.0	1200	9.6	52.3
P5KE5.0CA	6.40	7.25	10	5.0	1200	9.2	54.3
P5KE6.0C	6.67	8.45	10	6.0	1200	11.4	43.9
P5KE6.0CA	6.67	7.67	10	6.0	1200	10.3	48.5
P5KE6.5C	7.22	9.14	10	6.5	800	12.3	40.7
P5KE6.5CA	7.22	8.30	10	6.5	800	11.2	44.7
P5KE7.0C	7.78	9.86	10	7.0	300	13.3	37.8
P5KE7.0CA	7.78	8.95	10	7.0	300	12.0	41.7
P5KE7.5C	8.33	10.67	1	7.5	100	14.3	35.0
P5KE7.5CA	8.33	9.58	1	7.5	100	12.9	38.8
P5KE8.0C	8.89	11.30	1	8.0	50	15.0	33.3
P5KE8.0CA	8.89	10.23	1	8.0	50	13.6	36.7
P5KE8.5C	9.44	11.92	1	8.5	25	15.9	31.4
P5KE8.5CA	9.44	10.82	1	8.5	25	14.4	34.7
P5KE9.0C	10.0	12.6	1	9.0	5	16.9	29.5
P5KE9.0CA	10.0	11.5	1	9.0	5	15.4	32.5
P5KE10C	11.1	14.1	1	10	3	18.8	26.6
P5KE10CA	11.1	12.8	1	10	3	17.0	29.4
P5KE11C	12.2	15.4	1	11	3	20.1	24.9
P5KE11CA	12.2	14.0	1	11	3	18.2	27.4
P5KE12C	13.3	16.9	1	12	3	22.0	22.7
P5KE12CA	13.3	15.3	1	12	3	19.9	25.1
P5KE13C	14.4	18.2	1	13	3	23.8	21.0
P5KE13CA	14.4	16.5	1	13	3	21.5	23.2
P5KE14C	15.6	19.8	1	14	3	25.8	19.4
P5KE14CA	15.6	17.9	1	14	3	23.2	21.5
P5KE15C	16.7	21.1	1	15	3	26.9	18.8
P5KE15CA	16.7	19.2	1	15	3	24.4	20.6
P5KE16C	17.8	22.6	1	16	3	28.8	17.6
P5KE16CA	17.8	20.5	1	16	3	26.0	19.2
P5KE17C	18.9	23.9	1	17	3	30.5	16.4
P5KE17CA	18.9	21.7	1	17	3	27.6	16.1
P5KE18C	20.0	25.3	1	18	3	32.2	15.5
P5KE18CA	20.0	23.3	1	18	3	29.2	17.2
P5KE20C	22.2	28.1	1	20	3	35.8	13.9
P5KE20CA	22.2	25.5	1	20	3	32.4	15.4

For parts without A, the VBR is +10%.

Electrical Characteristics @ 25°C Unless Otherwise Specified

MCC PART NUMBER	BREAKDOWN VOLTAGE V(BR) @ IT (VOLTS)		TEST CURRENT IT	RATED STANDOFF VOLTAGE VWM	MAXIMUM REVERSE LEAKAGE ID @VWM	MAXIMUM CLAMPING VOLTAGE VC @ IPP	MAXIMUM PEAK PULSE CURRENT IPP
	MIN	MAX	mADC	V	(μ A)	V	A
P5KE22C	24.4	30.9	1	22	3	39.4	12.7
P5KE22CA	24.4	28.0	1	22	3	35.5	14.1
P5KE24C	26.7	33.8	1	24	3	43.0	11.6
P5KE24CA	26.7	30.7	1	24	3	38.9	12.8
P5KE26C	28.9	36.6	1	26	3	46.6	10.7
P5KE26CA	28.9	33.2	1	26	3	42.1	11.9
P5KE28C	31.1	39.4	1	28	3	50.0	9.9
P5KE28CA	31.1	35.8	1	28	3	45.4	11.0
P5KE30C	33.3	42.2	1	30	3	53.5	9.3
P5KE30CA	33.3	38.3	1	30	3	48.4	10.3
P5KE33C	36.7	46.5	1	33	3	59.0	5.8
P5KE33CA	36.7	42.2	1	33	3	53.3	9.4
P5KE36C	40.0	50.7	1	36	3	64.3	7.8
P5KE36CA	40.0	46.0	1	36	3	58.1	8.6
P5KE40C	44.4	56.3	1	40	3	71.4	7.0
P5KE40CA	44.4	51.1	1	40	3	64.5	7.8
P5KE43C	47.8	60.5	1	43	3	76.7	6.5
P5KE43CA	47.8	54.9	1	43	3	69.4	7.2
P5KE45C	50.0	63.3	1	45	3	80.3	6.2
P5KE45CA	50.0	57.5	1	45	3	72.7	6.9
P5KE48C	53.3	67.5	1	48	3	85.5	5.8
P5KE48CA	53.3	61.3	1	48	3	77.4	6.5
P5KE51C	56.7	71.8	1	51	3	91.1	5.5
P5KE51CA	56.7	65.2	1	51	3	82.4	6.1
P5KE54C	60.0	76.0	1	54	3	96.3	5.2
P5KE54CA	60.0	69.0	1	54	3	87.1	5.7
P5KE58C	64.4	81.6	1	58	3	103	4.9
P5KE58CA	64.4	74.1	1	58	3	93.6	5.3
P5KE60C	66.7	84.5	1	60	3	107	4.7
P5KE60CA	66.7	76.7	1	60	3	96.8	5.2
P5KE64C	71.1	90.1	1	64	3	114	4.4
P5KE64CA	71.1	81.8	1	64	3	103	4.9
P5KE70C	77.8	98.6	1	70	3	125	4.0
P5KE70CA	77.8	89.5	1	70	3	113	4.4
P5KE75C	83.3	105.7	1	75	3	134	3.7
P5KE75CA	83.3	95.8	1	75	3	121	4.1
P5KE78C	86.7	109.8	1	78	3	139	3.6
P5KE78CA	86.7	99.7	1	78	3	126	4.0
P5KE85C	94.4	119.2	1	85	3	151	3.3
P5KE85CA	94.4	108.2	1	85	3	137	3.6
P5KE90C	100	126.5	1	90	3	160	3.1
P5KE90CA	100	115.5	1	90	3	146	3.4
P5KE100C	111	141.0	1	100	3	179	2.8
P5KE100CA	111	128.0	1	100	3	162	3.1
P5KE110C	122	154.5	1	110	3	196	2.6

For parts without A, the VBR is +10%.

Electrical Characteristics @ 25°C Unless Otherwise Specified

MCC PART NUMBER	BREAKDOWN VOLTAGE V(BR) @ IT (VOLTS)		TEST CURRENT IT	RATED STANDOFF VOLTAGE VWM	MAXIMUM REVERSE LEAKAGE ID @VWM	MAXIMUM CLAMPING VOLTAGE VC @ IPP	MAXIMUM PEAK PULSE CURRENT IPP
	MIN	MAX	mADC	V	(μ A)	V	A
P5KE110CA	122	140.5	1	110	3	177	2.8
P5KE120C	133	169.0	1	120	3	214	2.3
P5KE120CA	133	153.0	1	120	3	193	2.0
P5KE130C	144	182.5	1	130	3	231	2.2
P5KE130CA	144	165.5	1	130	3	209	2.4
P5KE150C	167	211.5	1	150	3	268	1.9
P5KE150CA	167	192.5	1	150	3	243	2.1
P5KE160C	178	226.0	1	160	3	287	1.7
P5KE160CA	178	205.0	1	160	3	259	1.9
P5KE170C	189	239.5	1	170	3	304	1.6
P5KE170CA	189	217.5	1	170	3	275	1.8
P5KE180C	198	253.8	1	180	3	322	1.6
P5KE180CA	198	230.4	1	180	3	292	1.7
P5KE190C	209	267.9	1	190	3	340	1.5
P5KE190CA	209	243.2	1	190	3	308	1.6
P5KE200C	220	282.0	1	200	3	358	1.4
P5KE200CA	220	256.0	1	200	3	324	1.5

For parts without A, the VBR is +10%.

Curve Characteristics

Fig. 1 - Peak Pulse Power Rating Curve

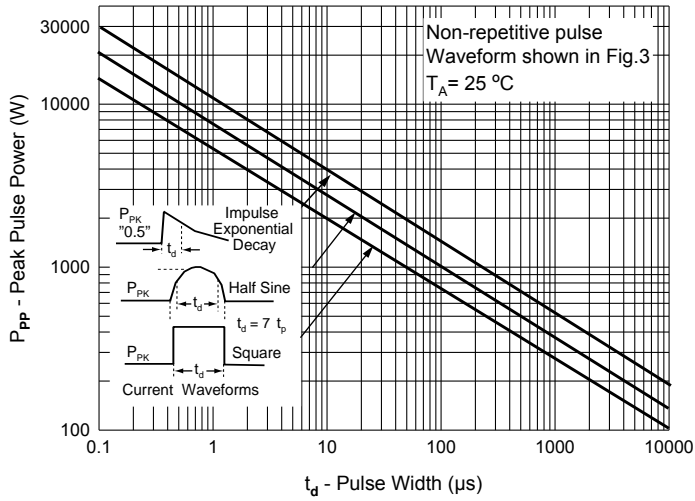

Fig. 2 - Typical Junction Capacitance

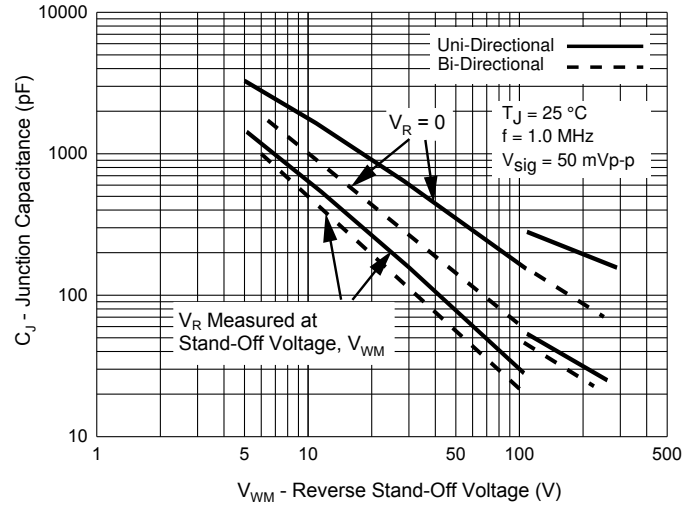

Fig. 3 - Pulse Waveform

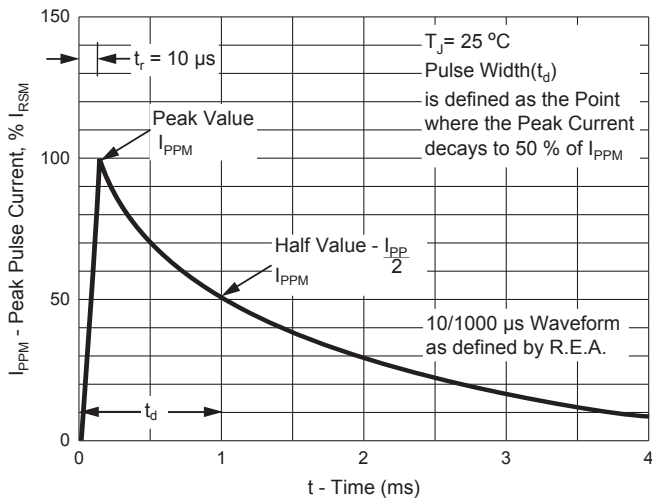
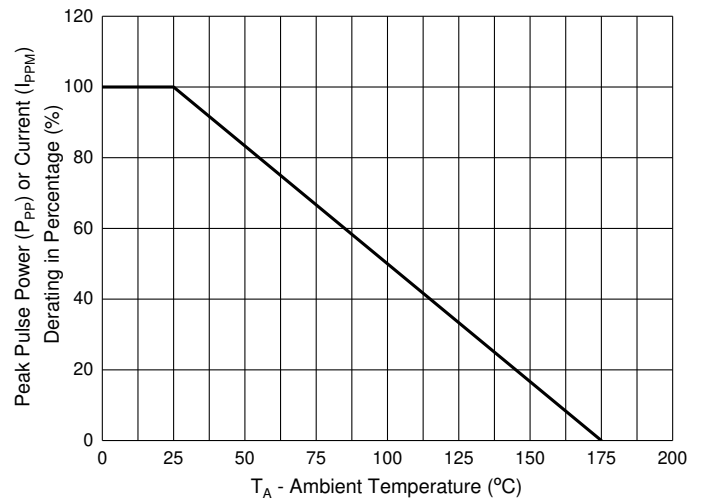

Fig. 4 - Pulse Derating Curve



Ordering Information

Device	Packing
(Part Number)-TP	Tape&Reel: 4Kpcs/Reel
(Part Number)-AP	Ammo Packing: 3Kpcs/Ammo Box
(Part Number)-BP	Bulk:500pcs/Box,25Kpcs/Carton

Note : Adding "-HF" Suffix For Halogen Free, eg. Part Number-TP-HF

IMPORTANT NOTICE

Micro Commercial Components Corp. reserves the right to make changes without further notice to any product herein to make corrections, modifications , enhancements , improvements , or other changes . **Micro Commercial Components Corp .** does not assume any liability arising out of the application or use of any product described herein; neither does it convey any license under its patent rights ,nor the rights of others . The user of products in such applications shall assume all risks of such use and will agree to hold **Micro Commercial Components Corp .** and all the companies whose products are represented on our website, harmless against all damages. **Micro Commercial Components Corp.** products are sold subject to the general terms and conditions of commercial sale, as published at <https://www.mccsemi.com/Home/TermsAndConditions>.

LIFE SUPPORT

MCC's products are not authorized for use as critical components in life support devices or systems without the express written approval of Micro Commercial Components Corporation.

CUSTOMER AWARENESS

Counterfeiting of semiconductor parts is a growing problem in the industry. Micro Commercial Components (MCC) is taking strong measures to protect ourselves and our customers from the proliferation of counterfeit parts. MCC strongly encourages customers to purchase MCC parts either directly from MCC or from Authorized MCC Distributors who are listed by country on our web page cited below. Products customers buy either from MCC directly or from Authorized MCC Distributors are genuine parts, have full traceability, meet MCC's quality standards for handling and storage. **MCC will not provide any warranty coverage or other assistance for parts bought from Unauthorized Sources.** MCC is committed to combat this global problem and encourage our customers to do their part in stopping this practice by buying direct or from authorized distributors.