

SECTION A-A

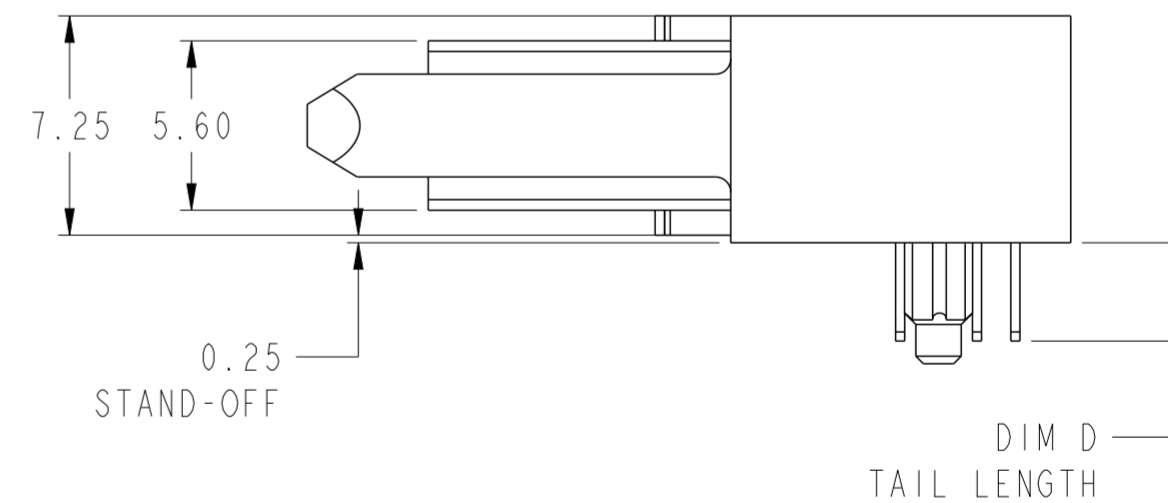
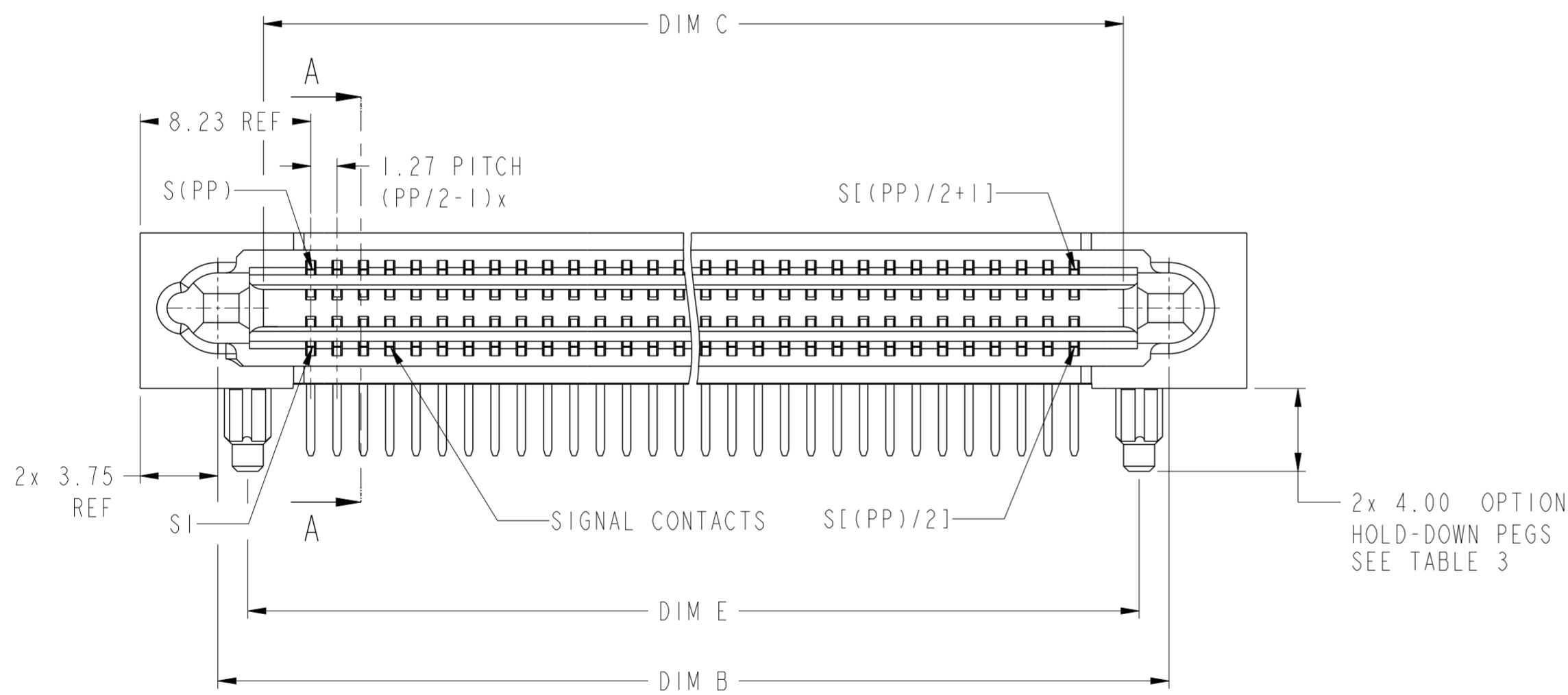

Amphenol
FCi

© 2016 AFci

spec ref	-	dr	De-Ming Lu	2014/01/15	projection	MM	size	A2	scale	4:1	
tolerance std	ISO 406 ISO 1101	eng	Leborn Luo	2017/09/30			ecn no	ELX-DG-28072-1	rel level	Released	
TOLERANCES UNLESS OTHERWISE SPECIFIED		chr	Kaka Zhang	2017/10/11							
		appr	Pei-Ming Zheng	2017/10/11							
surface	linear	0.X	±0.5		product family		title HPCE BTB R/A RECEPTACLE S CONFIG - UNIVERSAL	dwg no 10128276	rev B		
		0.XX	±0.25		cat. no.					Product - Customer Drw	sheet 1 of 3
	angular	0°	±2°		PDS: Rev :B						

CONTACT TYPE	TOP LAYER DESCRIPTION	TABLE 1 (HPCE / SOLDER TAILS) PLATED THROUGH-HOLE REQUIREMENTS				
		DRILLED HOLE DIAMETER	COPPER THICKNESS	TIN-LEAD THICKNESS	TIN THICKNESS	FINISHED HOLE DIAMETER
POWER & SIGNAL	TIN-LEAD	1.10-1.16 (1.15 DRILL)	0.025 - 0.050	0.005 - 0.015	--	0.94 - 1.10
	IMMERSION TIN	1.10-1.16 (1.15 DRILL)	0.025 - 0.050	--	0.9 - 1.5um	0.94 - 1.10
	COPPER (SEE NOTE 8)	1.10-1.16 (1.15 DRILL)	0.025 - 0.050	--	--	0.94 - 1.10

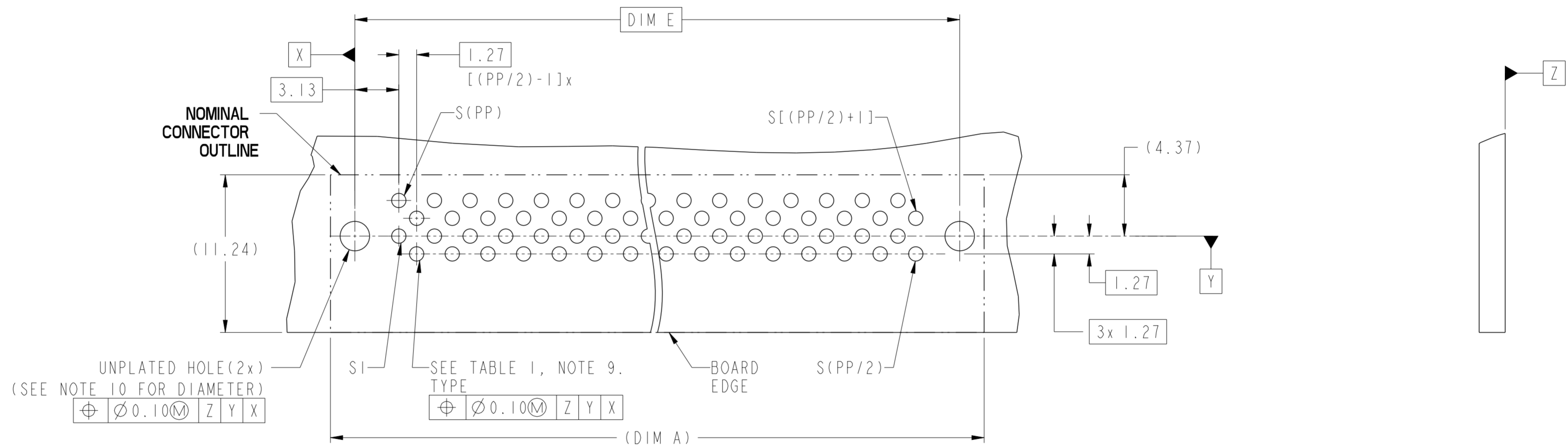

RECOMMENDED PCB LAYOUT

spec ref	-	dr	De-Ming Lu	2014/01/15	projection	MM	size	A2	scale	4:1
tolerance std	ISO 406 ISO 1101	eng	Leborn Luo	2017/09/30			ecn no	ELX-DG-28072-1	rel level	Released
TOLERANCES UNLESS OTHERWISE SPECIFIED		chr	Kaka Zhang	2017/10/11						
		appr	Pei-Ming Zheng	2017/10/11						
surface	ISO 1302	linear	0.X	±0.5	product family	HPCE BTB R/A RECEPTACLE	cat. no.	10128276	Product - Customer Drw	sheet 2 of 3
		angular	0°	±2°	title	S CONFIG - UNIVERSAL	rev	B		

10128276 - 00 00 PP - LF

LEAD FREE

	A	B	C	D	E	F	G	H
TAIL LENGTH(DIM D)	2.60	3.25	4.05	4.85				
HOLD-DOWN PEGS OPTION	Y	N	Y	N	Y	N	Y	N

SIGNAL CONTACTS

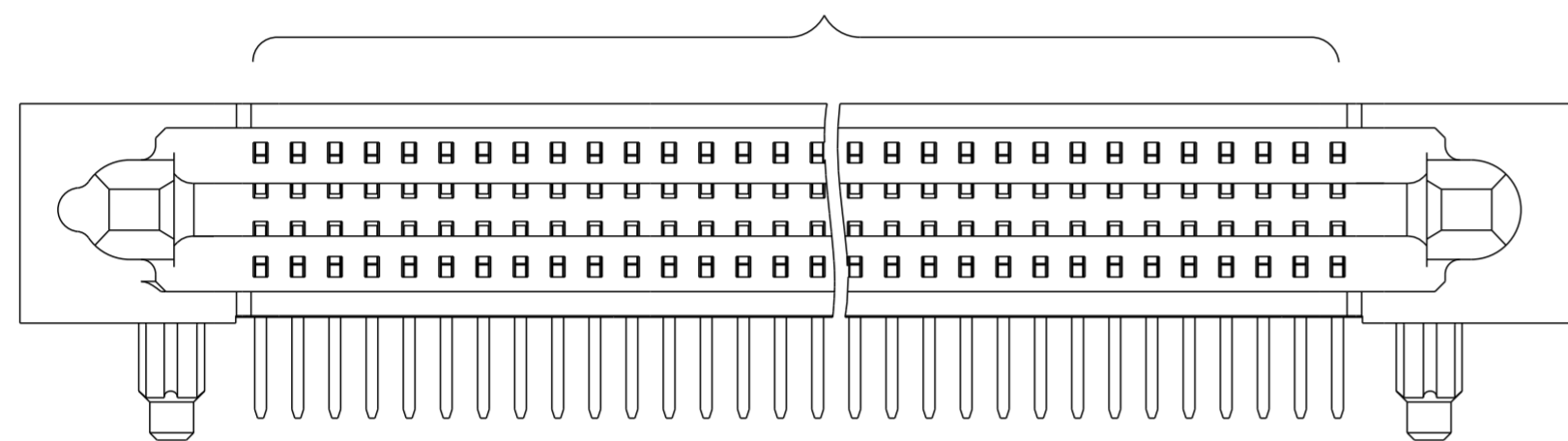

DIM	TABLE 2. LENGTH FORMULAS
DIM A (11)	$(PP / 2) \times 1.27 + 15.28$
DIM B	DIM A - 7.50
DIM C	DIM A - 11.90
DIM D	2.60 OR 3.25 OR 4.05 OR 4.85
DIM E	DIM A - 10.38

Example: The configuration above is 10128276-0000PPCLF
STD HPCE BTB R/A REC with Hold-Down Pegs.

TABLE 3: PART NUMBER CODE. HPCE BTB R/A RECPT S UNIVERSAL CONFIG

NOTES:

- CONNECTOR MATERIALS:
HOUSING: HIGH TEMPERATURE THERMAL PLASTIC, BLACK
UL 94V-0 COMPLIANT
CONTACTS: HIGH PERFORMANCE COPPER ALLOY.
- CONTACT FINISH REF. GS-12-1125.
- PRODUCT SPECIFICATION: GS-12-1125.
- APPLICATION SPECIFICATION: GS-20-0388.
- PRODUCT MARKING (FCI - PART NUMBER & DATE CODE) ON HOUSING IN AREA SHOWN.
- PACKAGING MEETS FCI SPECIFICATION GS-14-2272.
- HOUSING COMPONENT WILL WITHSTAND EXPOSURE TO 260°C PEAK TEMPERATURE FOR 60 SECONDS IN A CONVECTION, INFRA-RED, OR VAPOR PHASE REFLOW OVEN.
- COPPER PLATING THICKNESS IN CENTER OF VIA-HOLE CAN BE NO MORE THAN 0.003 LESS THAN OTHER AREAS.
- ALL HOLE SIZES ARE FINISHED HOLE SIZES.
- MOUNTING HOLES ARE UNPLATED
 $\varnothing 2.18 \pm 0.03$ FOR SOLDER TAILS
- MAXIMUM OVERALL LENGTH IS 43.22mm.

spec ref	-	dr	De-Ming Lu	2014/01/15	projection	MM	size	A2	scale	4:1
tolerance std	ISO 406 ISO 1101	eng	Leborn Luo	2017/09/30			ecn no	ELX-DG-28072-1		
TOLERANCES UNLESS OTHERWISE SPECIFIED		chr	Kaka Zhang	2017/10/11				rel level	Released	
surface	linear	0.X	±0.5	appr	Pai-Ming Zheng	2017/10/11	product family	HPCE BTB R/A RECEPTACLE		
		0.XX	±0.25	Amphenol FCI		title	S CONFIG - UNIVERSAL			
		0.XXX	±0.10	cat. no.		10128276	rev	B		
	angular	0°	±2°	Product - Customer Drw		sheet 3 of 3				