

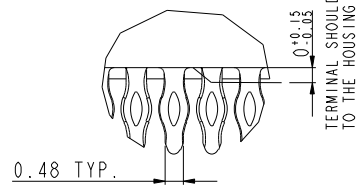

Copyright FCI.

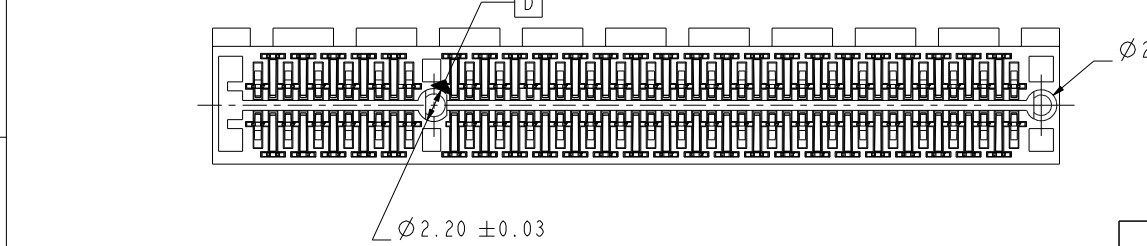

DETAIL T SCALE 5.000

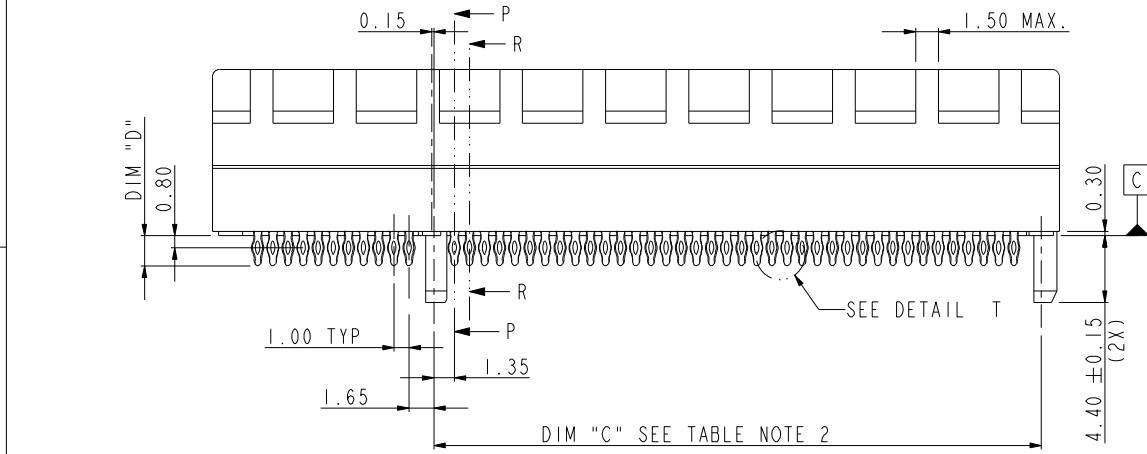
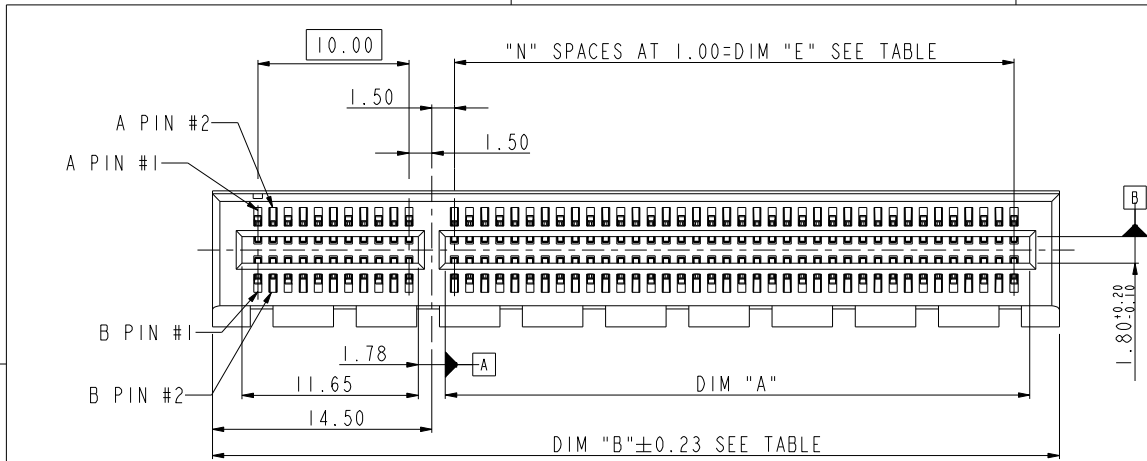
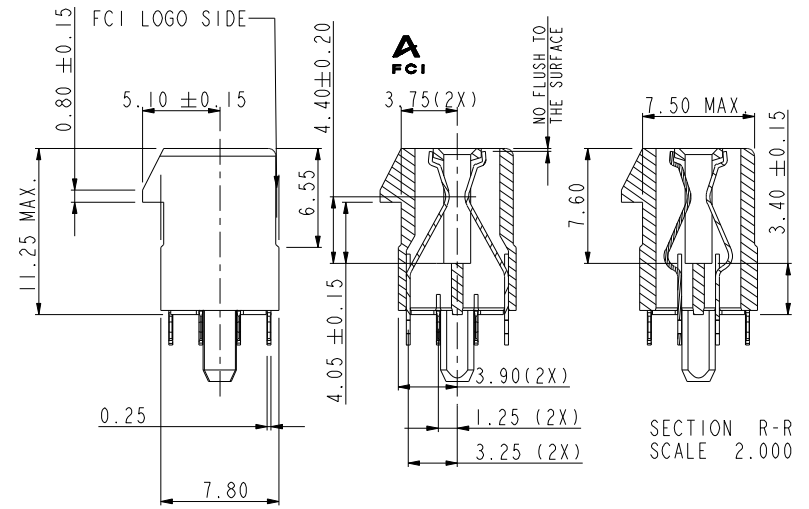

SECTION R-R SCALE 2.000

SECTION P-P SCALE 2.000

tolerance unless otherwise specified	
linear	.X ± .3 .XX ± .2 .XXX ± .1
angles	0° ± 2°

www.fciconnect.com			✓	tolerance	projection	MM
Dr	MAGGIE WU	07/23/04	Product family		size	A4
Eng	R Y LIU	07/23/04	Spec ref		Scale	1.000
Chr	PAUL WANG	07/23/04	Material		ECN	DG09-0045
Appr	JOSEPH HSIA	07/23/04				
FCI			PCI EXPRESS PRESS-FIT ASS'Y		dwg no	10039755
catalog no					Rev.	K
					* CUSTOMER DRAWING	sheet 1 of 6

rev	ecn no	dr	date
H	DG06-0161	P M	04/11/06
J	DG06-0249	P M	06/24/06
K	DG09-0045	B L	02/23/09
E	T05-0224	M W	09/27/05
F	T05-0243	M W	10/27/05
G	T05-0257	M W	11/08/05



Copyright FCI.

PIN #A1 IDENTIFIED BY SQUARE ANNULAR RING

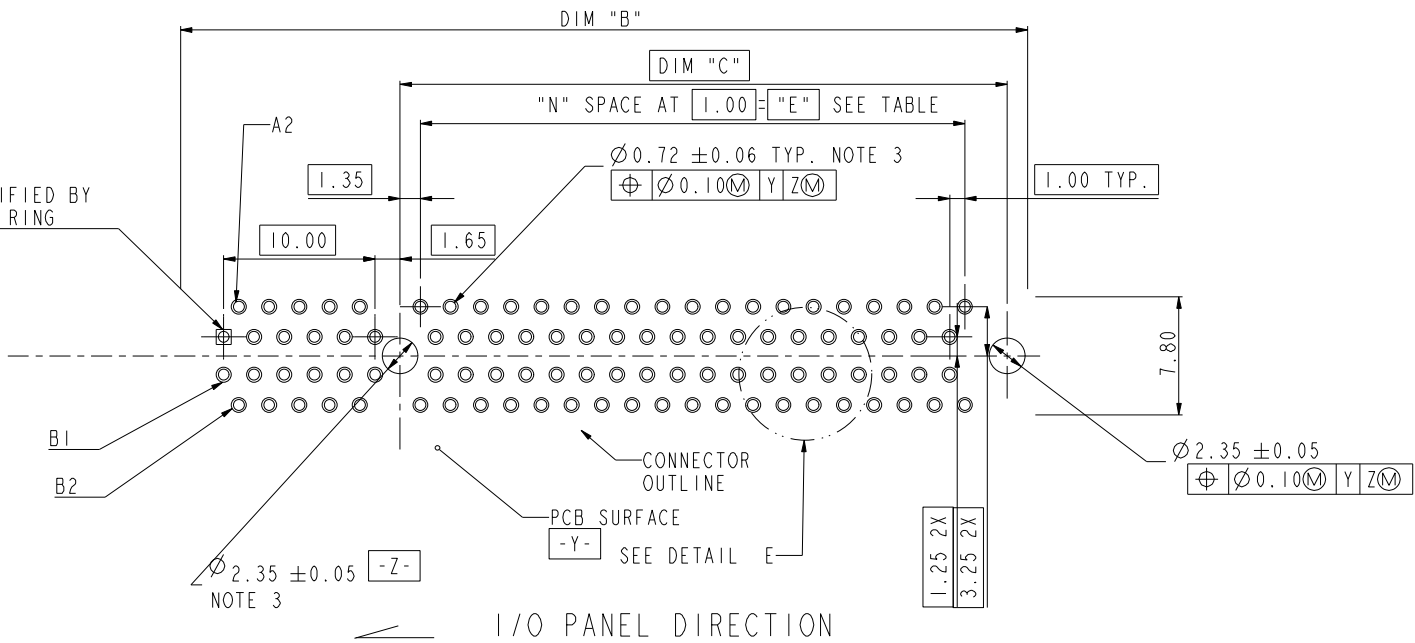

### RECOMMENDED FOOTPRINT

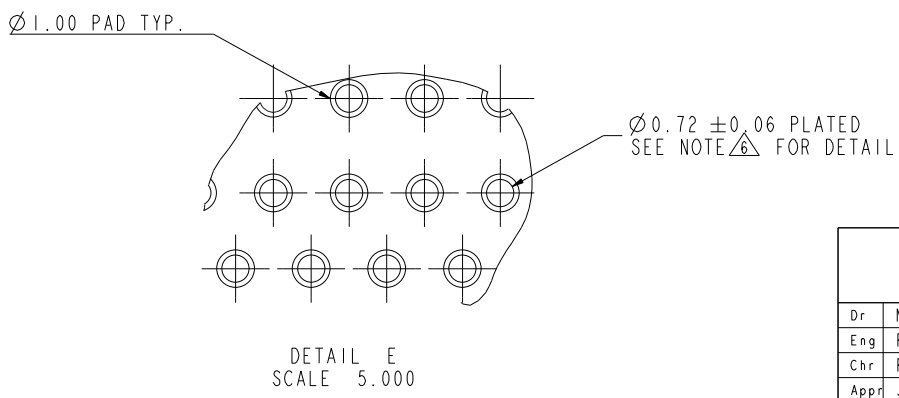

DETAIL E  
SCALE 5.000

tolerance unless otherwise specified	
linear	.X ± .3
	.XX ± .2
	.XXX ± .1
angles	0° ± 2°

www.fciconnect.com			tolerance	projection	MM
Dr	MAGGIE WU	07/23/04	Product family	size A4	Scale 1.000
Eng	R Y LIU	07/23/04	Spec ref	ECN	DG09-0045
Chr	PAUL WANG	07/23/04	Material		
Appr	JOSEPH HSIA	07/23/04			
FCI PCI EXPRESS PRESS-FIT ASS'Y			dwg no	10039755	Rev. K
catalog no			* CUSTOMER DRAWING sheet 2 of 6		



Copyright FCI.

A

B

C

D

1

2

3

4

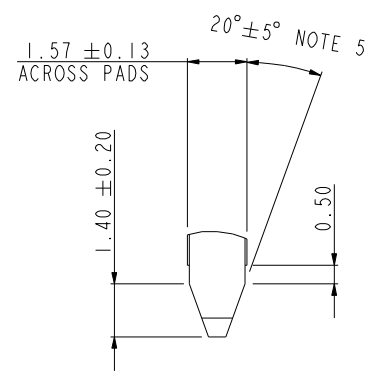
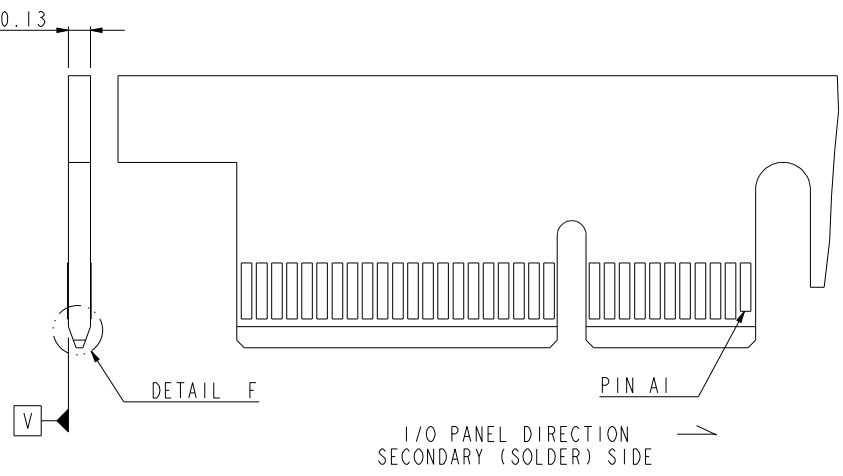
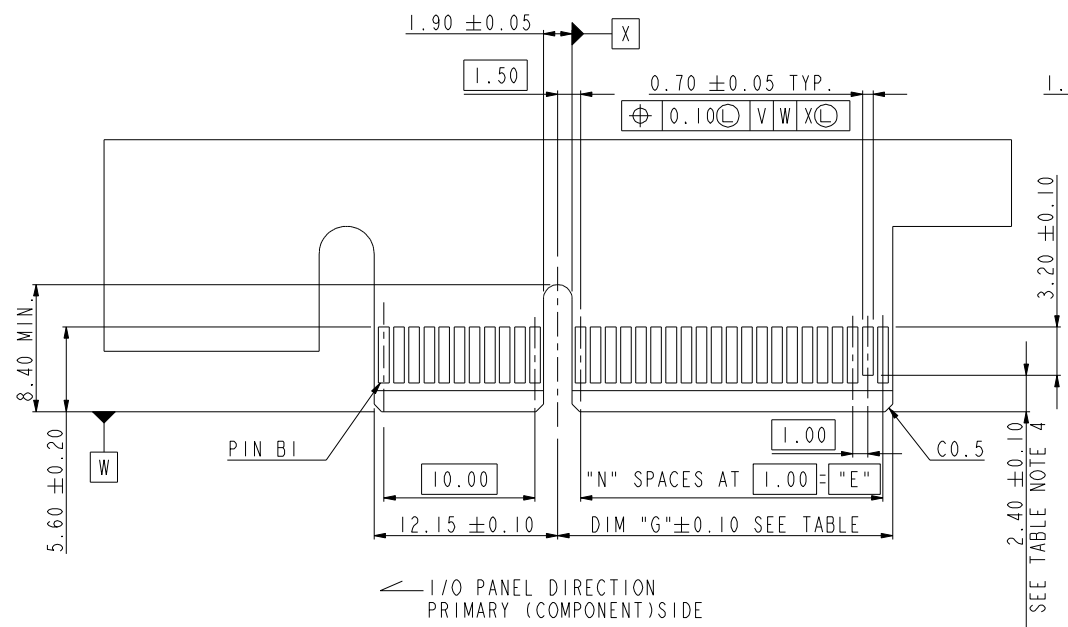

# POS REF.	N	DIM "G"	"F"
98	37	39.15	B48
164	70	72.15	B81

DETAIL F  
SCALE 5.000

tolerance unless otherwise specified	
linear	.X ± .3 .XX ± .2 .XXX ± .1
angles	0° ± 2°

www.fciconnect.com			tolerance	projection	MM
Dr	MAGGIE WU	07/23/04	Product family	size	A4
Eng	R Y LIU	07/23/04	Spec ref	Scale	1.000
Chr	PAUL WANG	07/23/04	Material	ECN	DG09-0045
Appr	JOSEPH HSIA	07/23/04			
FCI PCI EXPRESS PRESS-FIT ASS'Y			dwg no	10039755	Rev. K
catalog no			* CUSTOMER DRAWING sheet 3 of 6		

1

2

3

4

A

A

B

B

C

C

D

D

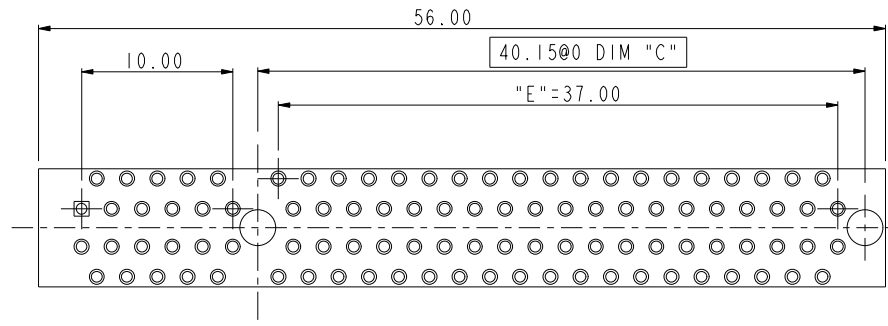

98p  
SCALE 2.000

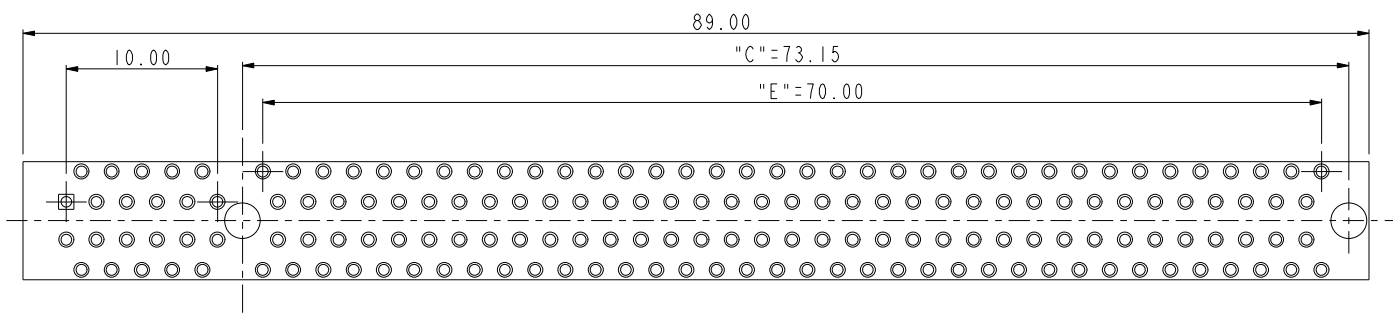

164P  
SCALE 2.000

# RECOMMENDED FOOTPRINT LAYOUT

www.fciconnect.com			✓ tolerance	projection	MM
Dr	MAGGIE WU	07/23/04	Product family	3G10	size A4
Eng	R Y LIU	07/23/04	Spec ref	*	Scale 1.000
Chr	PAUL WANG	07/23/04	Material	*	ECN DG09-0045
Appr	JOSEPH HSIA	07/23/04			
		PCI EXPRESS PRESS-FIT ASS'Y		dwg no	10039755
catalog no		*		CUSTOMER	sheet 4 of 6

2



Copyright FCI.

NOTES:

- MATERIAL:
  - HOUSING: HIGH TEMPERATURE NYLON, GLASS FILLED UL94V-0 RATED. SUITABLE FOR REFLOW SOLDERING.
  - TERMINAL: COPPER ALLOY
  - PLATING: 50u" NICKEL UNDERPLATE ALL OVER
  - CONTACT AREA PLATING - SEE PRODUCT NUMBER CODE
  - SOLDER TAIL: TIN - 100u" MIN. OVER 50u" NICKEL OR TIN/LEAD 100u" MIN. SEE PRODUCT NUMBER CODE
- PRODUCT SPECIFICATION: GS-12-319
  - THE HORIZONTAL AXIS FOR THE HOLE PATTERN IS ESTABLISHED BY A LINE THROUGH THE CENTER OF THE TWO Ø2.35 HOLES.
  - THE VERTICAL AXIS IS 90° TO THE HORIZONTAL AXIS, THROUGH THE CENTER OF DATUM Z.
  - NO TIE BAR PERMITTED FROM CARD EDGE TO LEADING EDGE OF PAD FOR PINS A1 AND PIN NUMBERS "F".
  - CHAMFER EDGES MUST BE FREE OF CUTTING BURRS.
  - ALL PTH SHOULD BE 0.76~0.83 mm DIA DRILLED AND 0.025~0.05 mm. ELECTRO-DEPOSITED COPPER THK ON THROUGH HOLE WALL.
- RoHS COMPATIBLE PRODUCT SPECIFICATIONS
  - a-PLATING:
    - "LF" MEANS THE PRODUCT IS LEAD-FREE, 2um MINIMUM MATTE TIN OVER 1.27um MINIMUM NICKEL UNDERPLATE.
  - b-MANUFACTURING PROCESS COMPATIBILITY
    - THE HOUSING WILL WITHSTAND EXPOSURE TO 260°C±5°C SOLDER BATH TEMPERATURE FOR 5 SECONDS IN A REFLOW SOLDER APPLICATION WITH A 1.6mm MIN THICK CIRCUIT BOARD.

CONNECTOR	# POS	REF.	N	DIM "A"	DIM "B"	DIM "C"	DIM "E"
1 PORT	36		6	7.65	25.00	9.15	6.00
4 PORT	64		20	21.65	39.00	23.15	20.00
8 PORT	98		37	38.65	56.00	40.15	37.00
16 PORT	164		70	71.65	89.00	73.15	70.00

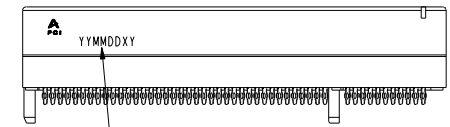

Date code:  
 "YY" means year number  
 "MM" means month number  
 "DD" means day number  
 "X" means manufacture location  
 "D" means made in Dongguan site  
 "Y" means shift number  
 If date code is 060626D1, it means this part is made by shift 1 in 2006/06/26 and manufactured in Dongguan site  
 Date code should be laser mark

PRODUCT NUMBER CODE

10039755 - X X X X X X X X

HOUSING COLOR OPTIONS  
1-BLACK

PEGS OPTIONS  
0-PLASTIC PEGS

TERMINAL PLATING OPTIONS

- 0-50u" Ni UNDERPLATE  
30u" Au CONTACT AREA  
100u" TIN TAIL AREA -----COMPATIBLE RoHS
- 1-50u" Ni UNDERPLATE  
15u" Au CONTACT AREA  
100u" TIN TAIL AREA -----COMPATIBLE RoHS
- 2-50u" Ni UNDERPLATE  
GOLD FLASH CONTACT AREA  
100u" TIN TAIL AREA -----COMPATIBLE RoHS
- 3-50u" Ni UNDERPLATE  
30u" Au CONTACT AREA  
100u" TIN/LEAD TAIL AREA -----RoHS COMPLIANT EXCEPT Pb
- 4-50u" Ni UNDERPLATE  
15u" Au CONTACT AREA  
100u" TIN/LEAD TAIL AREA -----RoHS COMPLIANT EXCEPT Pb
- 5-50u" Ni UNDERPLATE  
GOLD FLASH CONTACT AREA  
100u" TIN/LEAD TAIL AREA -----RoHS COMPLIANT EXCEPT Pb

LEAD FREE OPTION  
"LF" FOR TERMINAL PLATING OPTION 0,1,2  
LEAVE BLANK FOR TERMINAL PLATING 3,4,5

PACKAGING OPTIONS  
T-TRAY PACKAGING

POS OPTIONS

- 0-36
- 1-64
- 2-98
- 3-164

	DIM "D"	SUGGESTED PCB THICKNESS
0	2.00±0.20	2.36
1	3.25±0.20	4.19

TAIL LENGTH OPTIONS

tolerance unless otherwise specified	
linear	.X ± .3
	.XX ± .2
angles	.XXX ± .1
	0° ± 2°

www.fciconnect.com			tolerance	projection	MM
Dr	MAGGIE WU	07/23/04	size A4	Scale 1.000	ECN DG09-0045
Eng	R Y LIU	07/23/04			
Chr	PAUL WANG	07/23/04	Material		
Appr	JOSEPH HSIA	07/23/04	Product family		
FCI		PCI EXPRESS PRESS-FIT ASS'Y		dwg no	10039755
catalog no		* CUSTOMER DRAWING		sheet 5 of 6	
		Rev. K			



Copyright FCI.

1

2

3

4

A

B

C

D

A

B

C

D

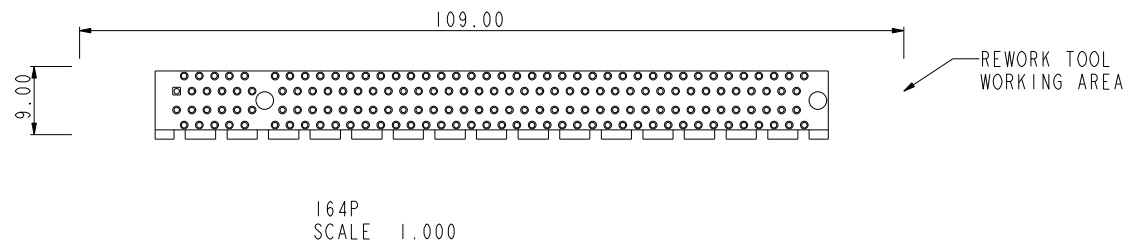
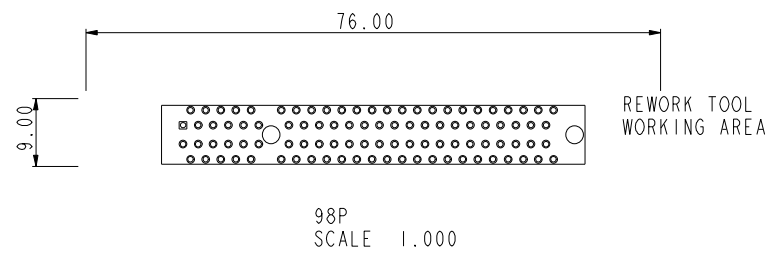
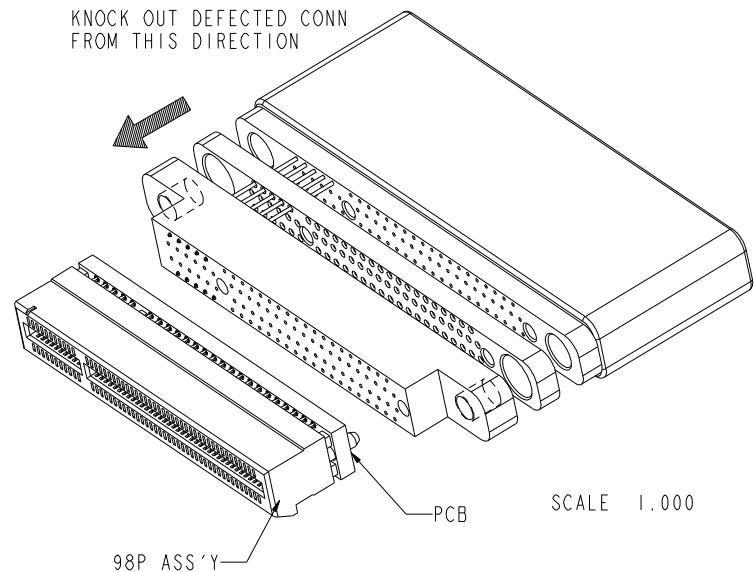

tolerance unless otherwise specified	
linear	.X ± .3 .XX ± .2 .XXX ± .1
angles	0° ± 2°

www.fciconnect.com			✓ tolerance	projection	MM
Dr	MAGGIE WU	07/23/04	Product family	size	A4
Eng	R Y LIU	07/23/04	Spec ref	Scale	1.000
Chr	PAUL WANG	07/23/04	Material	ECN	DG09-0045
Appr	JOSEPH HSIA	07/23/04			
FCI			PCI EXPRESS PRESS-FIT ASS'Y		Rev. K
catalog no	* CUSTOMER DRAWING			dwg no	10039755
			sheet 6 of 6		

REV F - 2006-04-17

2

PDM: Rev:K

STATUS:Released

4 Printed: Mar 15, 2011



Copyright FCI.