

THIS DRAWING IS UNPUBLISHED. RELEASED FOR PUBLICATION
 © COPYRIGHT - By - ALL RIGHTS RESERVED.

LOC		DIST		REVISIONS			
P	LTR	DESCRIPTION		DATE	DWN	APVD	
AF	50	F1	ECR-13-017177	05NOV13	PKS	RRP	

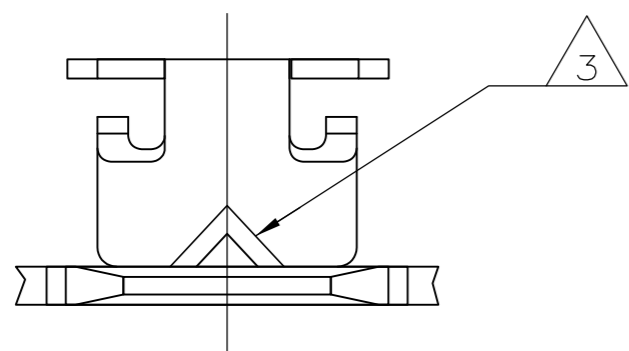

- 1 CONTINUOUS STRIP ON REELS WITH TERMINALS LOCATED ON 5.59±0.08 [.220±.003] CENTERS. SLOT ACCEPTS A SINGLE WIRE MAX OF 0.18-0.23mm [#33-#31] AWG COPPER MAGNET WIRE.
- 2 POKE-IN ACCEPTS A 0.5-0.8mm² [#20-#18] AWG SOLID OR FUSED STRANDED LEAD WIRE.
- 3 AFTER INSERTION INTO PLASTIC HOLDER TAB TO 90° OR PORTION MUST BE BENT OVER 45°
- 4 POTTED-IN TO PREVENT PULL-OUT WHEN MATING RECEPTACLE IS DISCONNECTED.

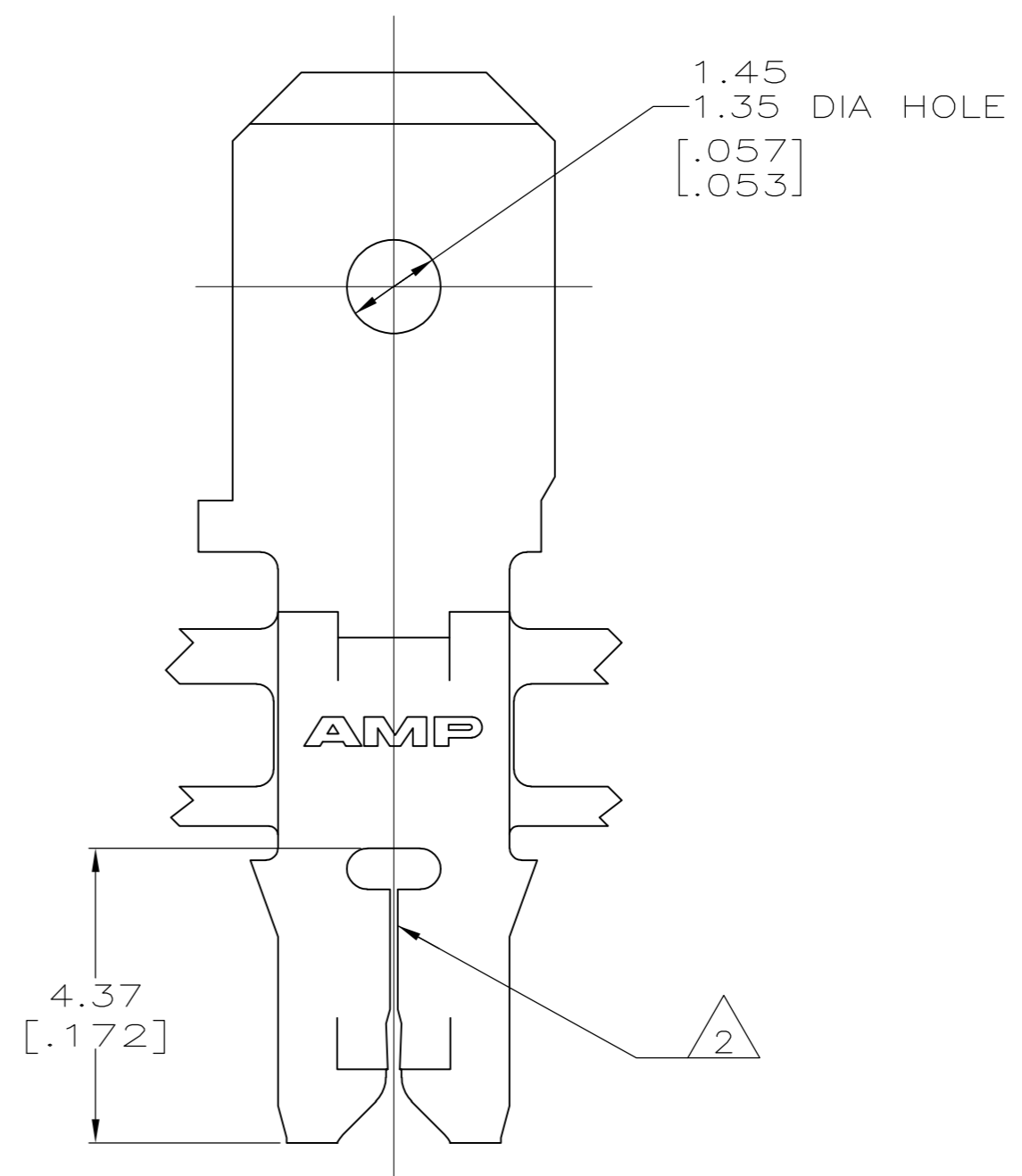
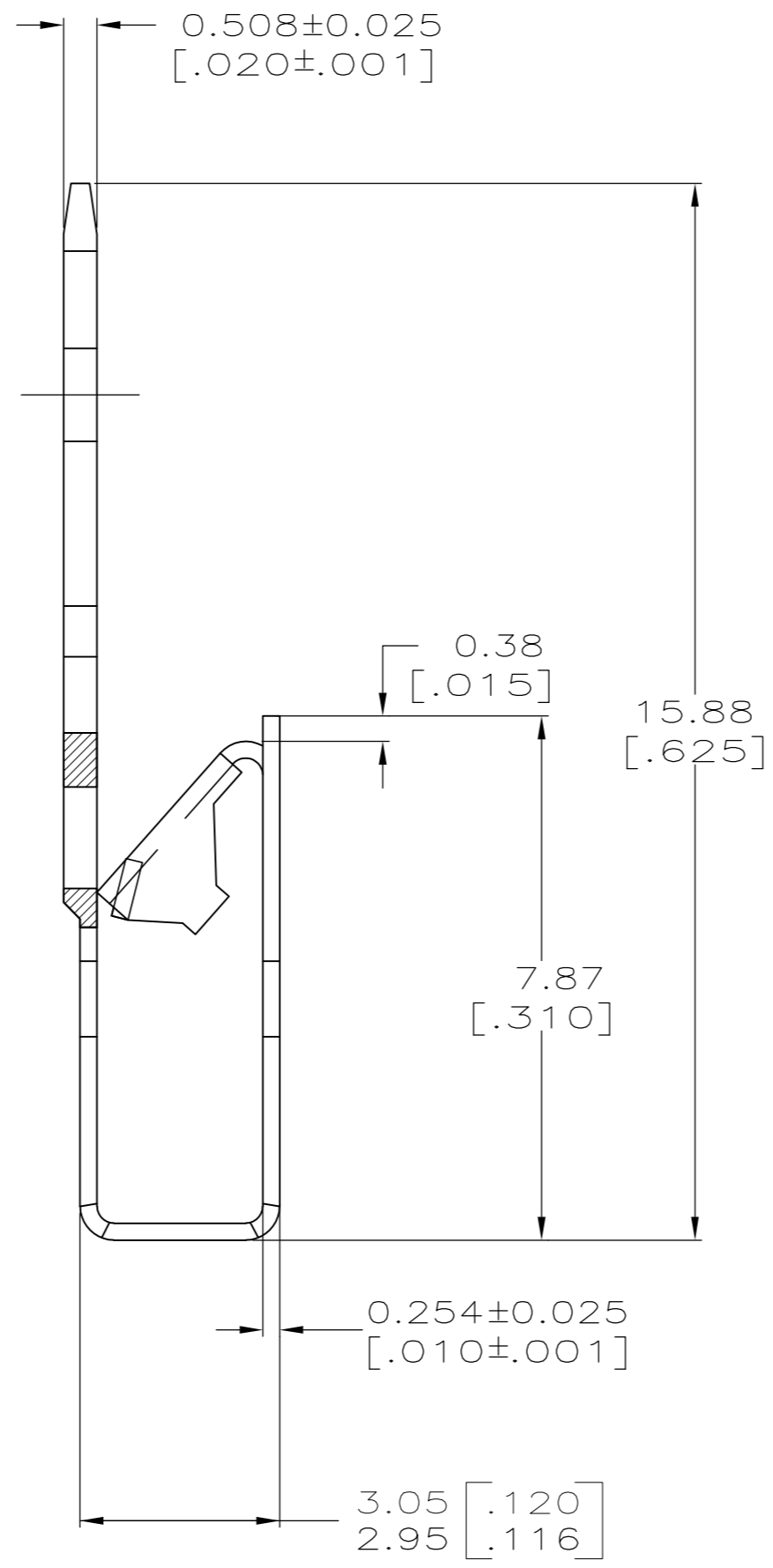
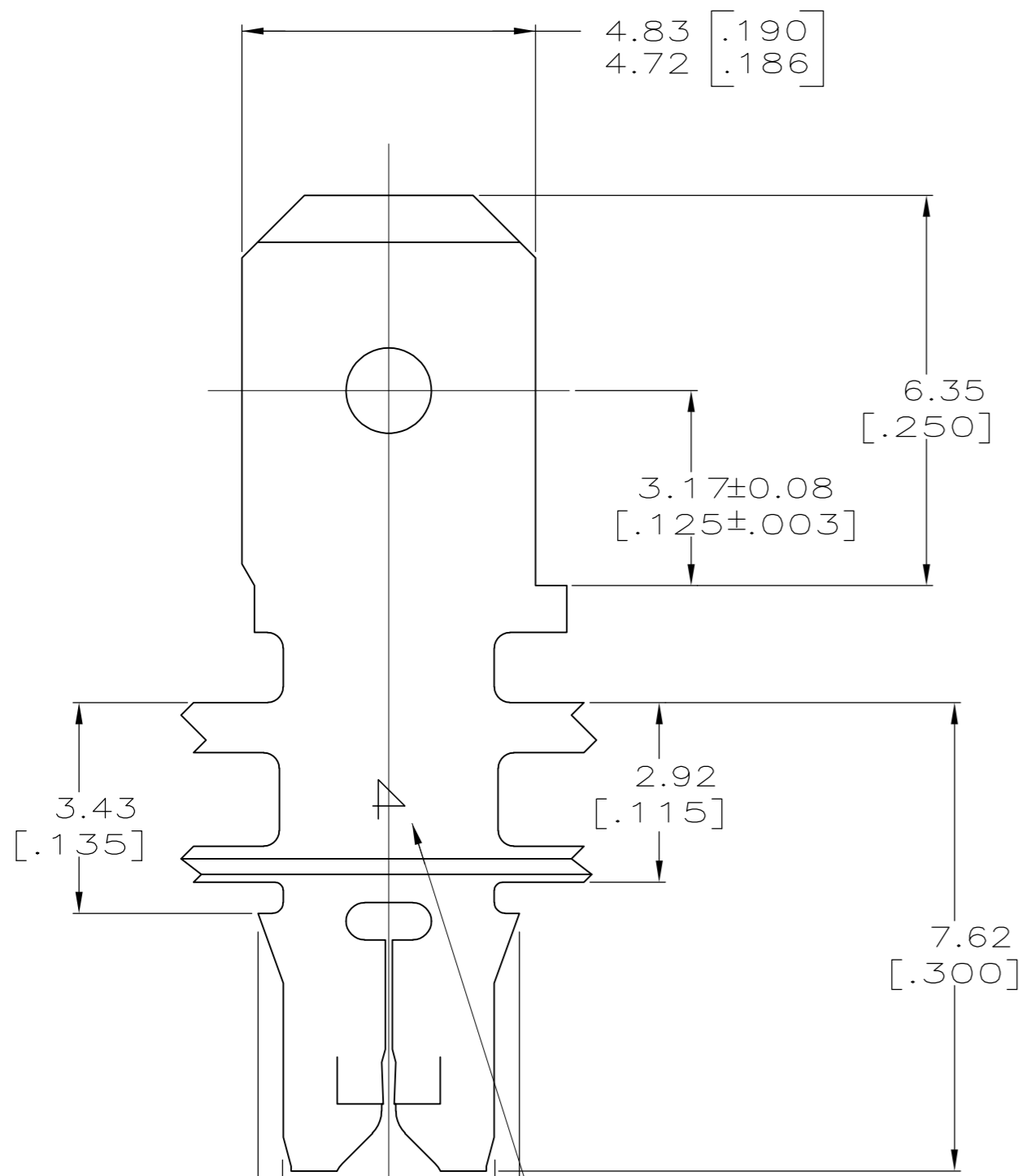

IDENTIFICATION NUMBER 4 FOR MAGNET WIRE RANGE

63018-1

THIS DRAWING IS A CONTROLLED DOCUMENT.		DWN	4-12-94			TE Connectivity TERMINAL, TAB, POKE-IN/4.75 [.187] FASTON™ COMBINATION, MAG-MATE™		
DIMENSIONS:		CHK	4-22-94					
INCHES		APVD	4-27-94					
TOLERANCES UNLESS OTHERWISE SPECIFIED: 0 PLC ± - 1 PLC ± - 2 PLC ± 0.25 [.010] 3 PLC ± - 4 PLC ± - ANGLES ± -		NAME						
MATERIAL		PRODUCT SPEC		SIZE		CAGE CODE	DRAWING NO	RESTRICTED TO
BRASS		FINISH		108-2012		A2	00779	63018
TIN PLATED		APPLICATION SPEC		114-2046		SCALE		SHEET
		WEIGHT		CUSTOMER DRAWING		10:1		1 OF 1
								REV
								F1