

4

3

2

1

THIS DRAWING IS UNPUBLISHED RELEASED FOR PUBLICATION - ,2018.

© COPYRIGHT - 2017 by TE Connectivity Germany GmbH ALL RIGHTS RESERVED.

REVISIONS

P	LTR	DESCRIPTION	DATE	DWN	APVD
	A2	REVISED PER ECR-19-000980	24JAN2019	SR	JDB

Material:

COVER : LCP, black, UL-94-V0
 HEADER : Black WH-9100, UL-94-V0
 LEAD FRAME: C5191-HV170-190 °
 SOLDER PIN PLATING: 7 μm (275 μ inch) TIN 1.27 μm (50 μ inch) NICKEL OVER ALL

- 2 THE PART IS RECOMMENDED FOR REFLOW SOLDERING PROCESS PEAK
 SOLDERING: TEMPERATURE MAX. +260 °C/-5 °C, MAX. 30s
- 3 OPERATING TEMPERATURE: T= -40 °C TO +105 °C
- 4 STORAGE TEMPERATURE: T= -40 °C TO +85 °C
- 5 MEET IEEE 802.3ab REQUIRMENT
- 6 UNLESS OTHERWISE SPECIFIED, SEE TABLE FOR ALL DIMENSIONS TOLERANCES
- 7 PACKAGING: REEL (T+R) ACCORDING TO PACKAGING SPECIFICATION 107-18128

SUGGESTED PCB LAYOUT

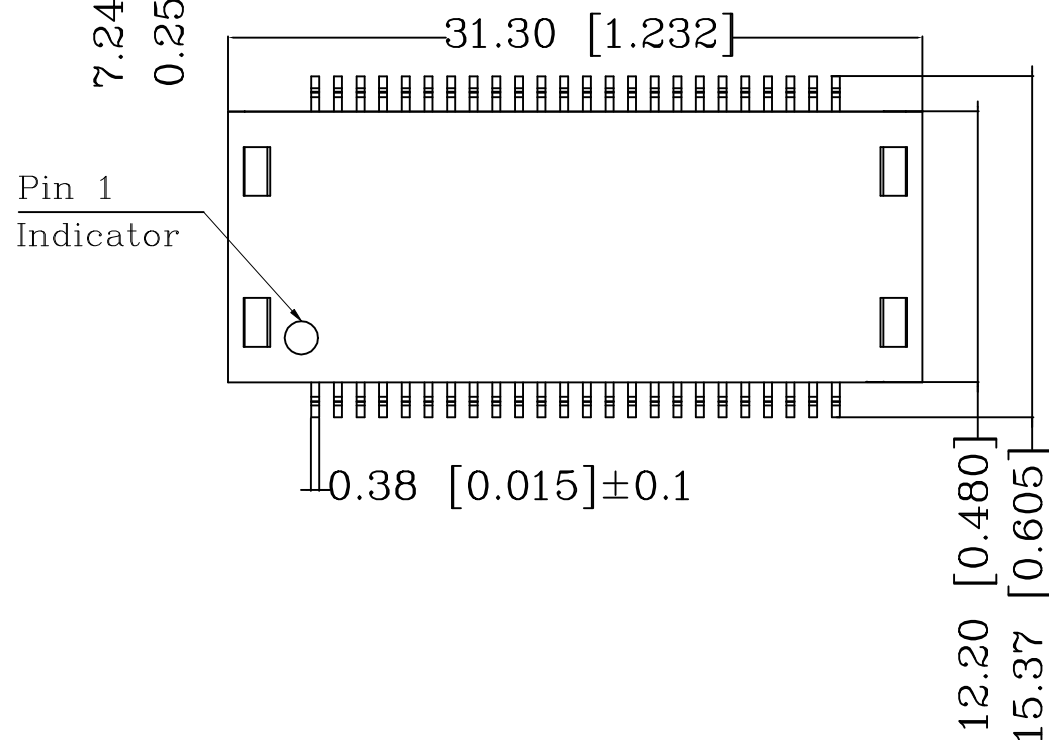
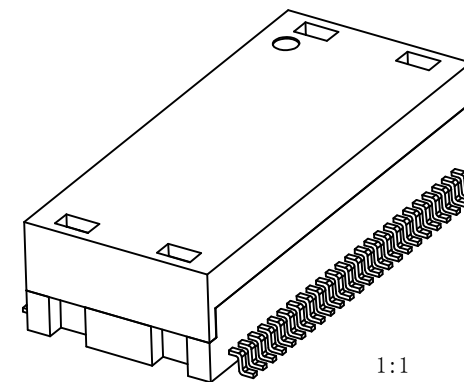
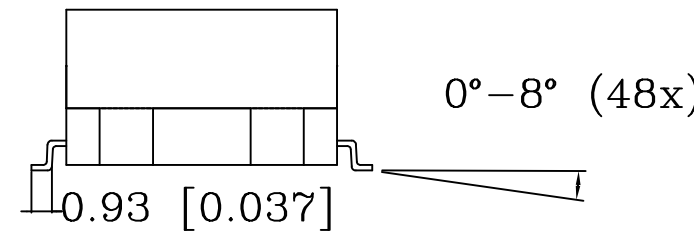
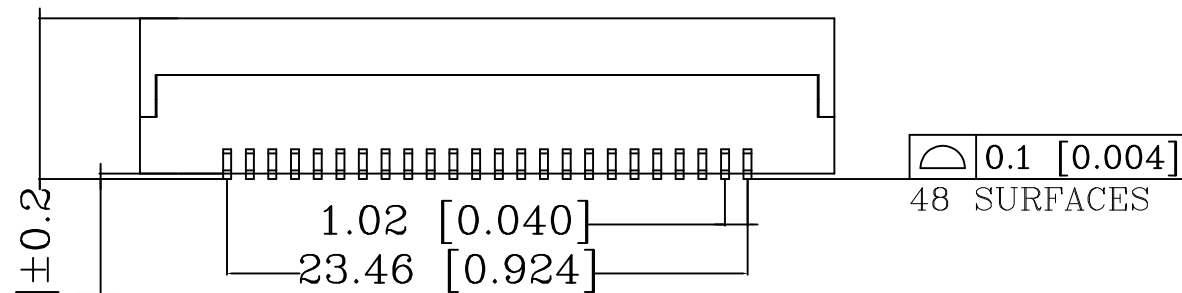
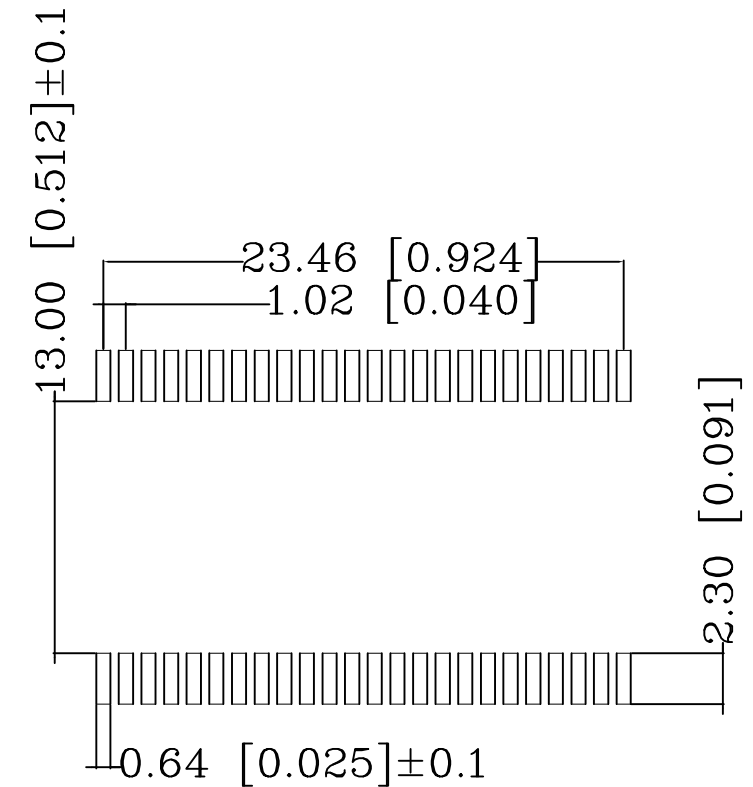

TABLE OF TOLERANCE (mm)	
RANGE	TOLERANCE
0-10	±0.15
>10-40	±0.25
>40-70	±0.30
>70	±0.40

THIS DRAWING IS A CONTROLLED DOCUMENT.		DWN 05JUL2018 GANESH C M	TE Connectivity												
		CHK 05JUL2018 A.C. NGOUMGANG													
DIMENSIONS: mm [INCHES]		APVD 05JUL2018 J. DE BRUIJN	NAME DISCR.ETH.MAG. 1G DUAL SMT												
TOLERANCES UNLESS OTHERWISE SPECIFIED:		PRODUCT SPEC 108-94693	SIZE CAGE CODE DRAWING NO RESTRICTED TO												
<table border="0"> <tr> <td>0 PLC ± -</td> <td rowspan="4">6</td> </tr> <tr> <td>1 PLC ± -</td> </tr> <tr> <td>2 PLC ± -</td> </tr> <tr> <td>3 PLC ± -</td> </tr> <tr> <td>4 PLC ± -</td> <td></td> </tr> <tr> <td>ANGLES ± -</td> <td></td> </tr> </table>		0 PLC ± -	6	1 PLC ± -	2 PLC ± -	3 PLC ± -	4 PLC ± -		ANGLES ± -		APPLICATION SPEC 114-94555	A3	00779	C=2337824-2	-
0 PLC ± -	6														
1 PLC ± -															
2 PLC ± -															
3 PLC ± -															
4 PLC ± -															
ANGLES ± -															
MATERIAL 1	FINISH 1	WEIGHT	CUSTOMER DRAWING		SCALE 3:1	SHEET 1 of 2	REV A2								

REVISIONS

P	LTR	DESCRIPTION	DATE	DWN	APVD
-	-	SEE SHEET 1	-	-	-

CIRCUIT DIAGRAM

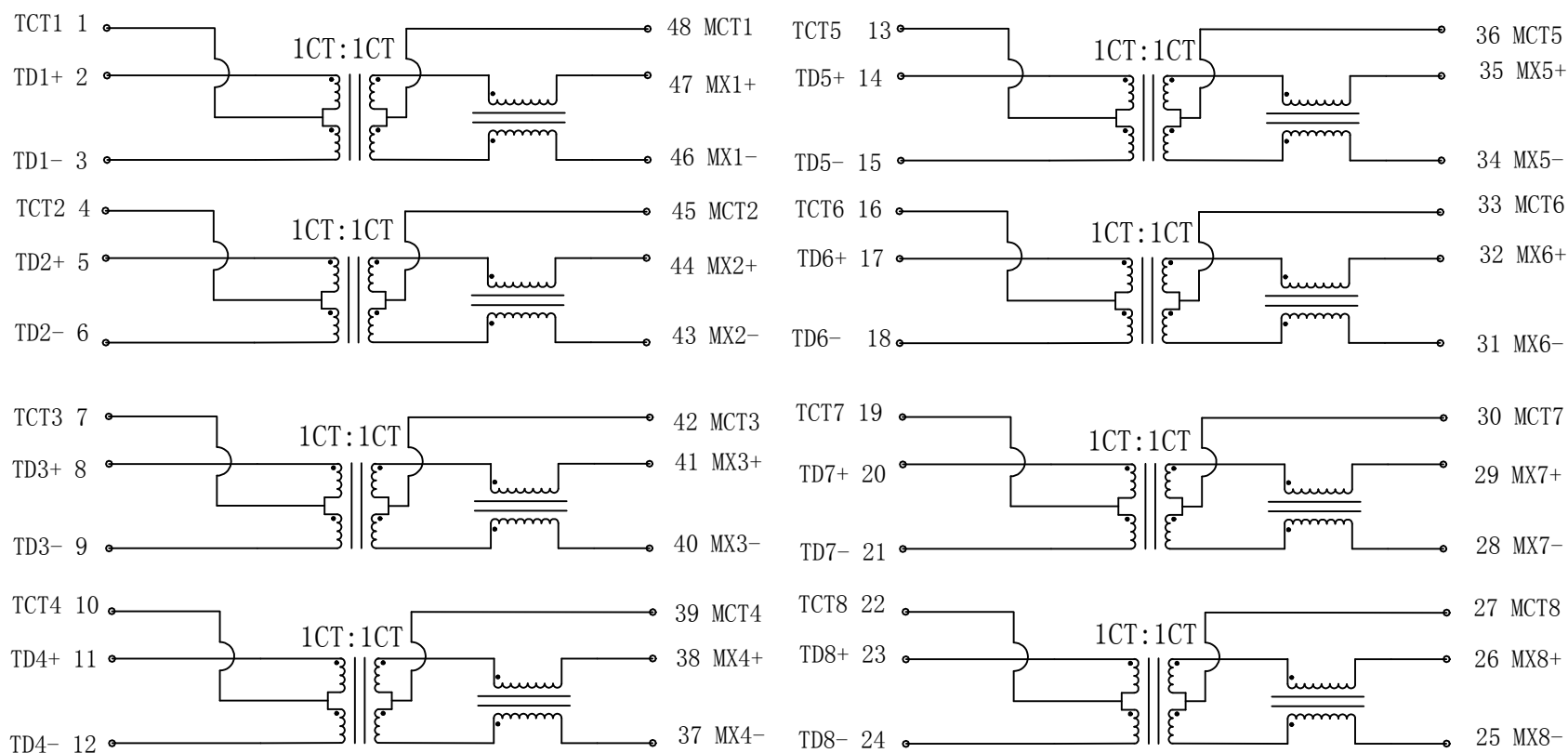

Electrical Specifications @ 25 °C
(Unless other specified meet IEEE 802.3 Specification)

Turn Ratio	1CT:1CT ±2%	
Inductance (OCL) @100kHz/0.1V with 8mA DC Bias	350 µH min.	
Insertion Loss	0.1-100MHz	-1 dB max.
	1-30MHz	-18 dB min.
Return Loss (Zout = 100 OHMS)	40MHz	-14.4 dB min.
	50MHz	-13.1 dB min.
	80MHz	-12 dB min.
	100MHz	-10 dB min.
Crosstalk	30MHz	-40 dB min.
	60MHz	-35 dB min.
	100MHz	-30 dB min.
DCMR	30MHz	-40 dB min.
	60MHz	-35 dB min.
	100MHz	-30 dB min.
Isolation Voltage (Input - Output)	1500 Vrms	



CONTROL CODE

DATE CODE

"0213"

YY-YEAR

WW-WEEK

THIS DRAWING IS A CONTROLLED DOCUMENT.

DIMENSIONS: mm [INCHES]	TOLERANCES UNLESS OTHERWISE SPECIFIED:	DWN GANESH C M 05JUL2018	TE Connectivity NAME DISCR.ETH.MAG. 1G DUAL SMT				
	0 PLC ± - 1 PLC ± - 2 PLC ± - 3 PLC ± - 4 PLC ± - ANGLES ± -	CHK A.C. NGOUMGANG 05JUL2018 APVD J. DE BRUIJN 05JUL2018				SIZE	CAGE CODE
MATERIAL	FINISH	PRODUCT SPEC 108-94693	A3	00779	C=2337824-2	-	
		APPLICATION SPEC 114-94555	CUSTOMER DRAWING		SCALE 3:1	SHEET 2 of 2	REV A2