

- 1. FOR MINI-APPLICATOR CRIMPING.
- 2. WIRE RANGE IS 22-26 AWG AND INSULATION RANGE IS 1.02/1.27 [.040/.050].
- 3. PLATED WITH 0.76μm [.000030] GOLD ON INSIDE OF LOCALIZED GOLD PLATE AREA, 2.54μm [.000100] TIN ON CRIMP BARRELS, ALL OVER 1.27μm [.000050] NICKEL UNDERPLATE.
-OR-
GOLD FLASH OVER PALLADIUM-NICKEL 0.76μm [.000030] TOTAL ON INSIDE OF LOCALIZED GOLD PLATE AREA, 2.54μm [.000100] TIN ON CRIMP BARRELS, ALL OVER 1.27μm [.000050] NICKEL UNDERPLATE.
- 4. COLOR CODE YELLOW IN THIS AREA INDICATES 22-26 AWG WIRE RANGE. ONLY LOOSE PIECE PART NUMBERS ARE COLOR CODED.
- 5. TIN PLATING MAY NOT APPEAR ON CARRIER STRIP.
- 6. GOLD FLASH ON INSIDE OF LOCALIZED PLATE AREA, 2.54μm [.000100] TIN PLATED ON CRIMP BARRELS, ALL OVER 1.27μm [.000050] NICKEL UNDERPLATE.

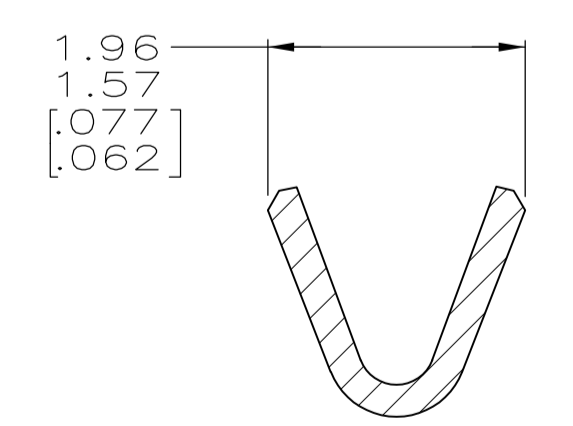
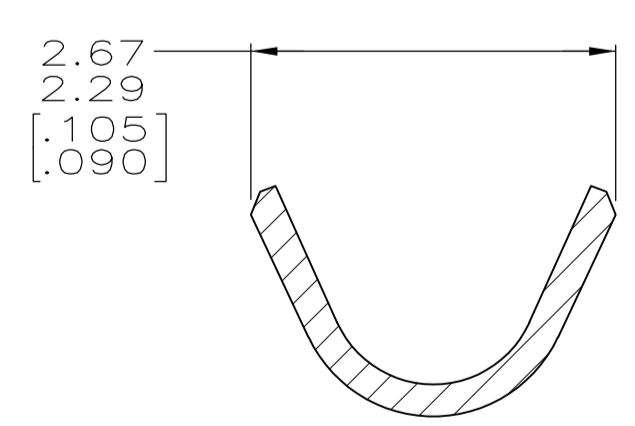
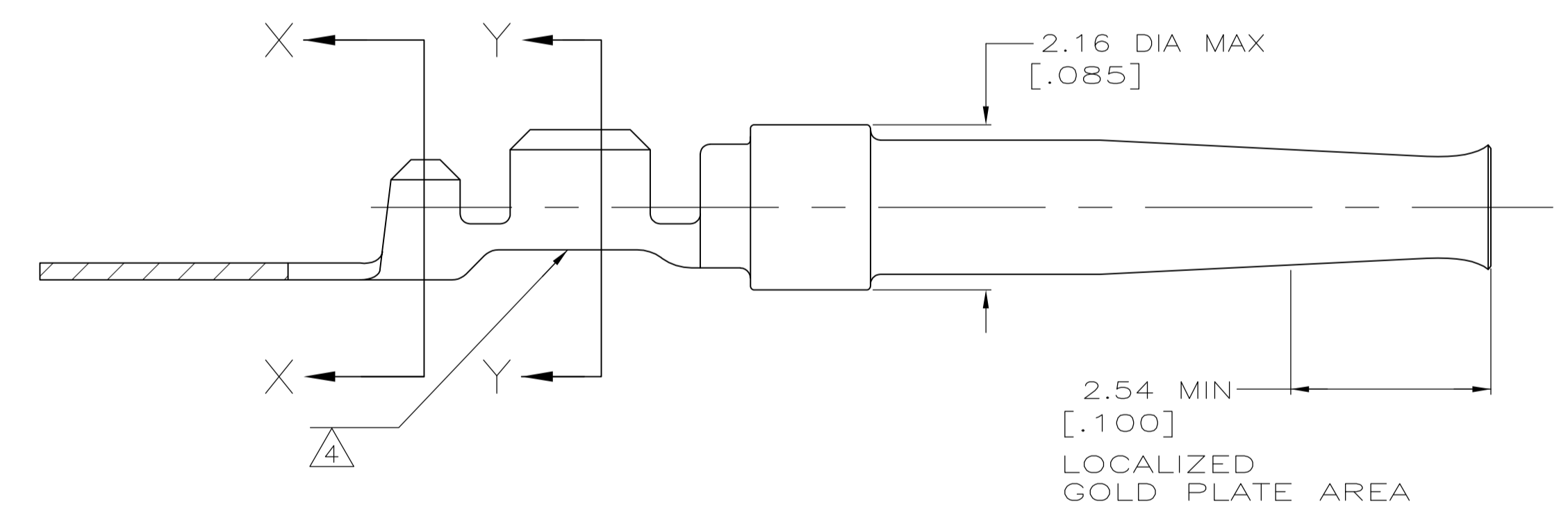

STANDARD	6	STRIP	1	1658543-3
STANDARD	3	STRIP	1	1658543-2
STANDARD	3	LOOSE PIECE		1658543-1
PACKAGING TYPE	FINISH	TYPE	PART NUMBER	

THIS DRAWING IS A CONTROLLED DOCUMENT.		DIN	11-17-04	Tyco Electronics Corporation Harrisburg, PA 17105-3608
		L. VARELA - DOCKS	11-17-04	
DIMENSIONS: INCHES		CHK	11-17-04	Tyco Electronics NAME: M. WALMSLEY
TOLERANCES UNLESS OTHERWISE SPECIFIED:		APVD	11-17-04	
0. PLC	± -	PRODUCT SPEC		
1. PLC	± -	108-40005		
2. PLC	± 0.13 [.005]	APPLICATION SPEC		
3. PLC	± -	114-10000		
4. PLC	± -	SIZE		
ANGLES	± °	CAGE CODE		
MATERIAL	PHOS BRONZE	FINISH	SEE TABLE	WEIGHT
		CUSTOMER DRAWING		SCALE 15:1
		DRAWING NO		RESTRICTED TO
		A1 00779		1658543
		SHEET 1 OF 1		REV D