



ANATECH ELECTRONICS INC
RF & Microwave Filters & Products

3 MHz Bandpass Filter

Part Number: AE3B9987



Electrical specifications

Center Frequency: 3.1 MHz
Insertion Loss: <8 dB
Return Loss @ fc: >15 dB
Rejection: >45 dB @ 0-100 kHz
Rejection 2: >45 dB @ 4.7-100 MHz
Input / Output Impedance: 50 Ohms

Mechanical

Connector Type: BNC (F)
Dimensions: 2.5 x 1.5 x 0.750 inches

Environmental

Operating Temperature: -45 to +85 deg.C
Storage Temperature: -55 to +95 deg.C
Shock: 20 G. 11ms
Vibration: 20 G. 5 to 200 MHz

Outline Drawing:

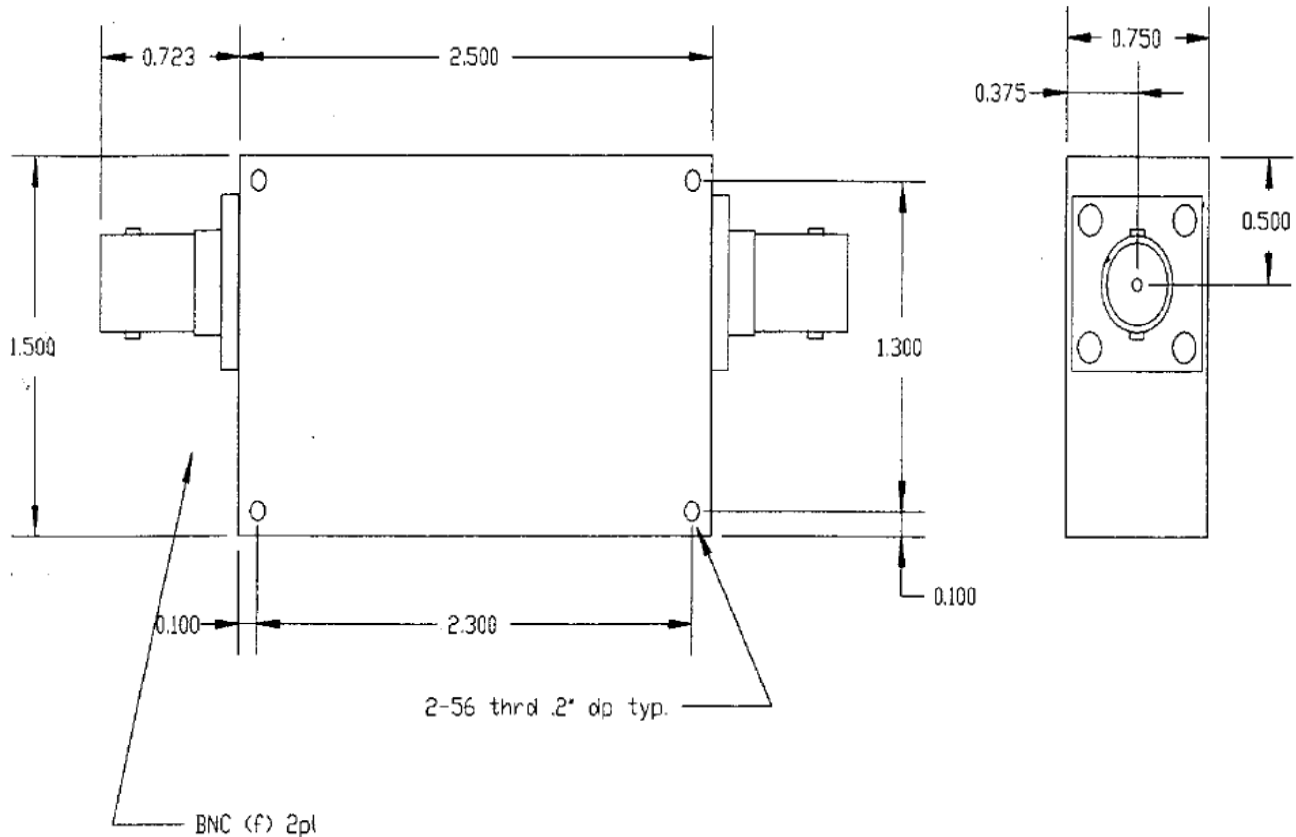



ANATECH ELECTRONICS INC
RF & Microwave Filters & Products

3 MHz Bandpass Filter

Part Number: AE3B9987



Response Plot:

