

THIS COPY IS PROVIDED ON A RESTRICTED BASIS AND IS NOT TO BE USED IN ANY WAY DETRIMENTAL TO THE INTERESTS OF PANDUIT CORPORATION.

PANDUIT PART NUMBER	CABLE TIE		DIMENSIONS								MATERIAL	WEIGHT grams/100pcs
	MIN TENSILE	MAX BUNDLE	'A'	'B'	'C' (REF)	'D'	'E' (REF)	'F'	'G'	'H' (REF)		
PUM-071-3S-D30	50LBS (222N)	3.00 (76.0)	1.5	6.0	10.4	16.9	16.5	1.3	4.8	292.0	HEAT STABILIZED NYLON 6/6 BLACK	217.4

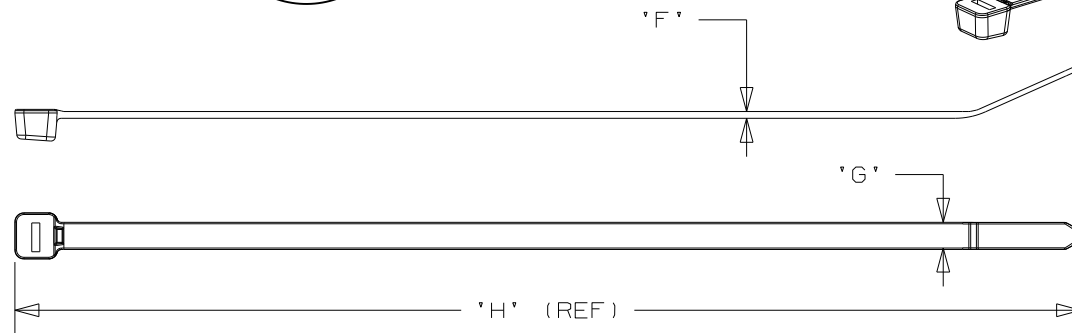
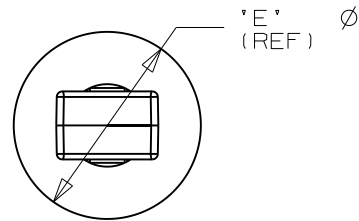
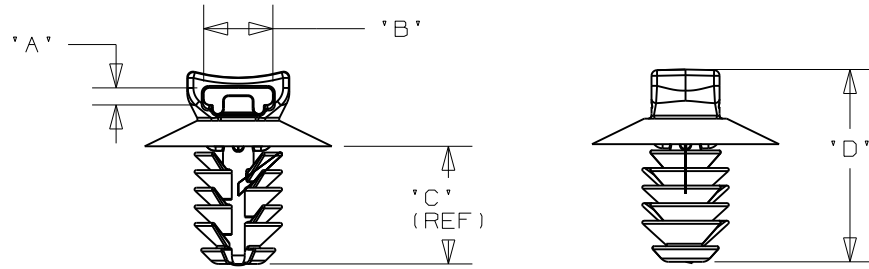

NOTES:

1. SEE CURRENT PRICE SHEET FOR PART NUMBER SUFFIX DESIGNATION FOR PACKAGE SIZE, AND COLOR.
2. (*) DIMENSIONAL VARIANCE IS POSSIBLE DUE TO MOLDING PROCESS RELATED SINK MARKS.
3. APPLICATION SPECIFICATION:
HOLE DIAMETER: 6.3 - 7.1 mm
PANEL THICKNESS: 0.8 - 7.0 mm

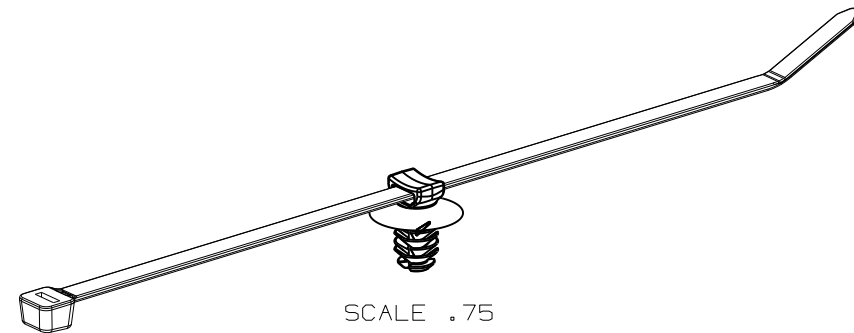

CAD FILENAME/LAYERS		G03151BB_DC_GB0239ND/10A	
PANDUIT CORP.		TINLEY PARK, ILLINOIS	
PUM-071-3S-D30 PUSH MOUNT / CABLE TIE ASSEMBLY			
UNLESS OTHERWISE SPECIFIED, ALL DIMENSIONS ARE METRIC TOLERANCE: ±0.5MM			
DRAWN BY	TMSA	MAT'L:	SCALE 1:1 UNLESS NOTED
DATE	6-19-07	SEE TABLE	DRAWING NO.
CHK'D			GB0239ND
			DWG SIZE A

REV	DATE	BY	CHK	DESCRIPTION	ECN	R	CUST	SUP
10A	8-22-08	PSG		REMOVED RIB FROM HEAD, UPDATED FILE NAME, AND CHANGED REV TO TC REV STYLE	GB0239ND	10A		
R	6-19-07	TMSA		INITIAL RELEASE	GB0239ND	R		