

Spansion[®] Analog and Microcontroller Products



The following document contains information on Spansion analog and microcontroller products. Although the document is marked with the name "Fujitsu", the company that originally developed the specification, Spansion will continue to offer these products to new and existing customers.

Continuity of Specifications

There is no change to this document as a result of offering the device as a Spansion product. Any changes that have been made are the result of normal document improvements and are noted in the document revision summary, where supported. Future routine revisions will occur when appropriate, and changes will be noted in a revision summary.

Continuity of Ordering Part Numbers

Spansion continues to support existing part numbers beginning with "MB". To order these products, please use only the Ordering Part Numbers listed in this document.

For More Information

Please contact your local sales office for additional information about Spansion memory, analog, and microcontroller products and solutions.

32-bit ARM™ Cortex™-M3 based Microcontroller

FM3 MB9A310A Series

**MB9AF311LA/MA/NA, MB9AF312LA/MA/NA,
MB9AF314LA/MA/NA, MB9AF315MA/NA, MB9AF316MA/NA**

■ DESCRIPTION

The MB9A310A Series are a highly integrated 32-bit microcontroller that target for high-performance and cost-sensitive embedded control applications.

The MB9A310A Series are based on the ARM Cortex-M3 Processor and on-chip Flash memory and SRAM, and peripheral functions, including Motor Control Timers, ADCs and Communication Interfaces (USB, UART, CSIO, I²C, LIN).

The products which are described in this data sheet are placed into TYPE1 product categories in " FM3 Family PERIPHERAL MANUAL " .

Note: ARM and Cortex are the trademarks of ARM Limited in the EU and other countries.

ARM™

MB9A310A Series

■ FEATURES

- 32-bit ARM Cortex-M3 Core
 - Processor version: r2p1
 - Up to 40MHz Frequency Operation
 - Integrated Nested Vectored Interrupt Controller (NVIC): 1 NMI (non-maskable interrupt) and 48 peripheral interrupts and 16 priority levels
 - 24-bit System timer (Sys Tick): System timer for OS task management

- On-chip Memories

[Flash memory]

- Up to 512 Kbyte
- Read cycle: 0wait-cycle
- Security function for code protection

[SRAM]

This Series contain a total of up to 32Kbyte on-chip SRAM memories. On-chip SRAM is composed of two independent SRAM (SRAM0,SRAM1) . SRAM0 is connected to I-code bus or D-code bus of Cortex-M3 core. SRAM1 is connected to System bus.

- SRAM0: Up to 16 Kbytes
- SRAM1: Up to 16 Kbytes

- External Bus Interface*

- Supports SRAM, NOR Flash device
- Up to 8 chip selects
- 8/16-bit Data width
- Up to 25-bit Address bit
- Supports Address/Data multiplex
- Supports external RDY function
- * : MB9AF311LA, F312LA and F314LA do not support External Bus Interface

- USB Interface

USB interface is composed of Function and Host.

[USB function]

- USB2.0 Full-Speed supported
- Max 6 EndPoint supported
 - EndPoint 0 is control transfer
 - EndPoint 1,2 can be selected Bulk-transfer, Interrupt-transfer or Isochronous-transfer
 - EndPoint 3,4 and 5 can be selected Bulk-transfer, Interrupt-transfer
- EndPoint1-5 is comprised Double Buffer

[USB host]

- USB2.0 Full/Low speed supported
- Bulk-transfer, interrupt-transfer and Isochronous-transfer support
- USB Device connected/dis-connected automatically detect
- IN/OUT token handshake packet automatically
- Max 256-byte packet-length supported
- Wake-up function supported

- Multi-function Serial Interface (Max 8channels)

- 4 channels with 16-byte FIFO (ch.4-ch.7), 4 channels without FIFO (ch.0-ch.3)
- Operation mode is selectable from the followings for each channel.
 - UART
 - CSIO
 - LIN
 - I²C

[UART]

- Full-duplex double buffer
- Selection with or without parity supported
- Built-in dedicated baud rate generator
- External clock available as a serial clock
- Hardware Flow control : Automatically control the transmission by CTS/RTS (only ch.4)*
- Various error detection functions available (parity errors, framing errors, and overrun errors)
 - * : MB9AF311LA, F312LA and F314LA do not support Hardware Flow control

[CSIO]

- Full-duplex double buffer
- Built-in dedicated baud rate generator
- Overrun error detection function available

[LIN]

- LIN protocol Rev.2.1 supported
- Full-duplex double buffer
- Master/Slave mode supported
- LIN break field generation (can be changed 13-16bit length)
- LIN break delimiter generation (can be changed 1-4bit length)
- Various error detection functions available (parity errors, framing errors, and overrun errors)

[I²C]

Standard mode (Max 100kbps) / High-speed mode (Max 400Kbps) supported

- DMA Controller (8channels)

The DMA Controller has an independent bus from the CPU, so CPU and DMA Controller can process simultaneously.

- 8 independently configured and operated channels
- Transfer can be started by software or request from the built-in peripherals
- Transfer address area: 32bit(4Gbytes)
- Transfer mode: Block transfer/Burst transfer/Demand transfer
- Transfer data type: byte/half-word/word
- Transfer block count: 1 to 16
- Number of transfers: 1 to 65536

- A/D Converter (Max 16channels)

[12-bit A/D Converter]

- Successive Approximation type
- Built-in 3unit*
- Conversion time: 1.0μs@5V
- Priority conversion available (priority at 2levels)
- Scanning conversion mode
- Built-in FIFO for conversion data storage (for SCAN conversion: 16steps, for Priority conversion: 4steps)
 - * : MB9AF311LA, F312LA, F314LA built-in 2unit

MB9A310A Series

- Base Timer (Max 8channels)

Operation mode is selectable from the followings for each channel.

- 16-bit PWM timer
- 16-bit PPG timer
- 16/32-bit reload timer
- 16/32-bit PWC timer

- General-Purpose I/O Port

This series can use its pins as general-purpose I/O ports when they are not used for external bus or peripherals. Moreover, the port relocate function is built in. It can set which I/O port the peripheral function can be allocated to.

- Capable of pull-up control per pin
- Capable of reading pin level directly
- Built-in the port relocate function
- Up to 83 fast General Purpose I/O Ports @ 100pin Package
- Some ports are 5V tolerant I/O (MB9AF315MA/NA, MB9AF316MA/NA only)
Please see "■PIN DESCRIPTION" to confirm the corresponding pins.

- Multi-function Timer (Max 2unit)

The Multi-function timer is composed of the following blocks.

- 16-bit free-run timer × 3ch/unit
- Input capture × 4ch/unit
- Output compare × 6ch/unit
- A/D activating compare × 3ch/unit
- Waveform generator × 3ch/unit
- 16-bit PPG timer × 3ch/unit

The following function can be used to achieve the motor control.

- PWM signal output function
- DC chopper waveform output function
- Dead timer function
- Input capture function
- A/D converter activate function
- DTIF (Motor emergency stop) interrupt function

- Quadrature Position/Revolution Counter (QPRC) (Max 2unit)

The Quadrature Position/Revolution Counter (QPRC) is used to measure the position of the position encoder. Moreover, it is possible to use up/down counter.

- The detection edge of the three external event input pins AIN, BIN and ZIN is configurable.
- 16-bit position counter
- 16-bit revolution counter
- Two 16-bit compare registers

- Dual Timer (32/16bit Down Counter)

The Dual Timer consists of two programmable 32/16-bit down counters.
Operation mode is selectable from the followings for each timer channel.

- Free-running
- Periodic (=Reload)
- One-shot

- **Watch Counter**

The Watch counter is used for wake up from Low-Power Consumption mode.

- Interval timer: up to 64s(Max)@ Sub Clock : 32.768kHz

- **External Interrupt Controller Unit**

- Up to 16 external interrupt input pins.
- Include one non-maskable interrupt (NMI) input pin.

- **Watch dog Timer (2channels)**

A watchdog timer can generate interrupts or a reset when a time-out value is reached.

This series consists of two different watchdogs, a "Hardware" watchdog and a "Software" watchdog.

The "Hardware" watchdog timer is clocked by the built-in low speed CR oscillator. Therefore, the "Hardware" watchdog is active in any low-power consumption modes except STOP.

- **CRC (Cyclic Redundancy Check) Accelerator**

The CRC accelerator calculates the CRC which has a heavy software processing load, and achieves a reduction of the integrity check processing load for reception data and storage.

CCITT CRC16 and IEEE-802.3 CRC32 are supported.

- CCITT CRC16 Generator Polynomial: 0x1021
- IEEE-802.3 CRC32 Generator Polynomial: 0x04C11DB7

- **Clock and Reset**

[Clocks]

Selectable from five clock sources (2 external oscillators, 2 built-in CR oscillators, and Main PLL).

- Main Clock : 4MHz to 48MHz
- Sub Clock : 32.768kHz
- Built-in high-speed CR Clock: 4MHz
- Built-in low-speed CR Clock: 100kHz
- Main PLL Clock

[Resets]

Reset requests from INITX pins, Power on reset, Software reset, watchdog timers reset, low-voltage detection reset and clock supervisor reset.

- **Clock Super Visor (CSV)**

Clocks generated by built-in CR oscillators are used to supervise abnormality of the external clocks.

- External clock failure (clock stop) is detected, reset is asserted.
- External frequency anomaly is detected, interrupt or reset is asserted.

- **Low-Voltage Detector (LVD)**

This Series include 2-stage monitoring of voltage on the VCC. When the voltage falls below the voltage that has been set, Low-Voltage Detector generates an interrupt or reset.

- LVD1: error reporting via interrupt
- LVD2: auto-reset operation

MB9A310A Series

- Low-Power Consumption Mode

Three Low-Power Consumption modes supported.

- SLEEP
- TIMER
- STOP

- Debug

- Serial Wire JTAG Debug Port (SWJ-DP)
- Embedded Trace Macrocells (ETM).*

*: MB9AF311LA/MA, F312LA/MA, F314LA/MA, F315MA and F316MA support only SWJ-DP.

- Power Supply

- Two Power Supplies
- VCC = 2.7V to 5.5V: Correspond to the wide range voltage.
- USBVCC = 3.0V to 3.6V: for USB I/O power supply, when USB is used.
= 2.7V to 5.5V: when GPIO is used.

MB9A310A Series

■ PRODUCT LINEUP

· Memory size

Product name	MB9AF311LA/MA/NA	MB9AF312LA/MA/NA	MB9AF314LA/MA/NA
On-chip Flash	64Kbytes	128Kbytes	256Kbytes
On-chip SRAM	16Kbytes	16Kbytes	32Kbytes

Product name	MB9AF315MA/NA	MB9AF316MA/NA
On-chip Flash	384Kbytes	512Kbytes
On-chip SRAM	32Kbytes	32Kbytes

· Function

Product name		MB9AF311LA MB9AF312LA MB9AF314LA	MB9AF311MA MB9AF312MA MB9AF314MA MB9AF315MA MB9AF316MA	MB9AF311NA MB9AF312NA MB9AF314NA MB9AF315NA MB9AF316NA
Pin count		64	80	100
CPU		Cortex-M3		
Freq.		40MHz		
Power supply voltage range		2.7V to 5.5V		
USB2.0 interface (Function/Host)		1ch.		
DMAC		8ch.		
External Bus Interface		-	Addr:21-bit (Max) Data:8-bit CS:4 (Max) Support: SRAM, NOR Flash	Addr:25-bit (Max) Data:8/16-bit CS:8 (Max) Support: SRAM, NOR Flash
Multi-function Serial Interface (UART/CSIO/LIN/I ² C)		8ch. (Max) ch.4 to ch.7: FIFO (16steps × 9-bit) ch.0 to ch.3: No FIFO		
Base Timer (PWC/ Reload timer/PWM/PPG)		8ch. (Max)		
MF- Timer	A/D activation compare	3ch.	1 unit	2 units (Max)
	Input capture	4ch.		
	Free-run timer	3ch.		
	Output compare	6ch.		
	Waveform generator	3ch.		
	PPG	3ch.		
QPRC		2ch. (Max)		
Dual Timer		1 unit		
Watch Counter		1 unit		
CRC Accelerator		Yes		
Watchdog timer		1ch. (SW) + 1ch. (HW)		
External Interrupts		8pins (Max)+ NMI × 1	11pins (Max)+ NMI × 1	16pins (Max)+ NMI × 1
I/O ports		51pins (Max)	66pins (Max)	83pins (Max)
12-bit A/D converter		9ch. (2 units)	12ch. (3 units)	16ch. (3 units)
CSV (Clock Super Visor)		Yes		

MB9A310A Series

Product name		MB9AF311LA MB9AF312LA MB9AF314LA	MB9AF311MA MB9AF312MA MB9AF314MA MB9AF315MA MB9AF316MA	MB9AF311NA MB9AF312NA MB9AF314NA MB9AF315NA MB9AF316NA
LVD (Low-Voltage Detector)		2ch.		
Built-in CR	High-speed	4MHz ($\pm 2\%$)		
	Low-speed	100kHz (Typ)		
Debug Function		SWJ-DP		SWJ-DP/ETM

Note: All signals of the peripheral function in each product cannot be allocated by limiting the pins of package.
It is necessary to use the port relocate function of the I/O port according to your function use.

MB9A310A Series

■ PACKAGES

Package	Product name	MB9AF311LA	MB9AF311MA	MB9AF311NA
		MB9AF312LA	MB9AF312MA	MB9AF312NA
		MB9AF314LA	MB9AF314MA	MB9AF314NA
			MB9AF315MA	MB9AF315NA
			MB9AF316MA	MB9AF316NA
LQFP:FPT-64P-M24/M38 (0.5mm pitch)		○	-	-
LQFP:FPT-64P-M23/M39 (0.65mm pitch)		○	-	-
QFN:LCC-64P-M24 (0.5mm pitch)		○	-	-
LQFP:FPT-80P-M21/M37 (0.5mm pitch)		-	○	-
LQFP:FPT-100P-M20/M23 (0.5mm pitch)		-	-	○
QFP:FPT-100P-M06 (0.65mm pitch)		-	-	○
BGA:BGA-112P-M04 (0.8mm pitch)		-	-	○*

○ : Supported

* : MB9AF315NA, MB9AF316NA are planning

Note: Refer to "■PACKAGE DIMENSIONS" for detailed information on each package.

MB9A310A Series

■ PIN ASSIGNMENT · FPT-100P-M20/M23

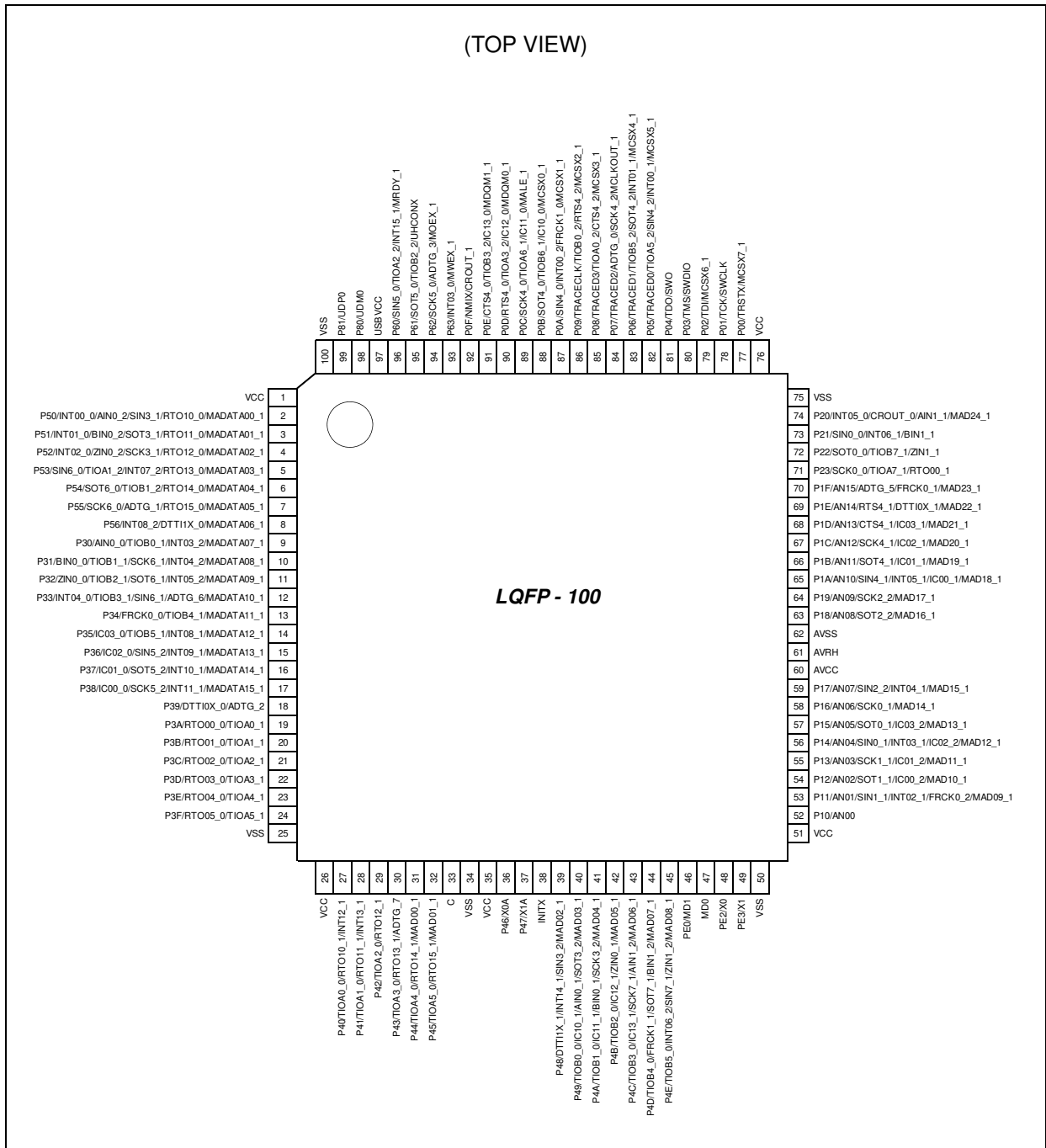

<Note>

The number after the underscore ("_") in pin names such as XXX_1 and XXX_2 indicates the relocated port number. For these pins, there are multiple pins that provide the same function for the same channel. Use the extended port function register (EPFR) to select the pin.

• FPT-100P-M06

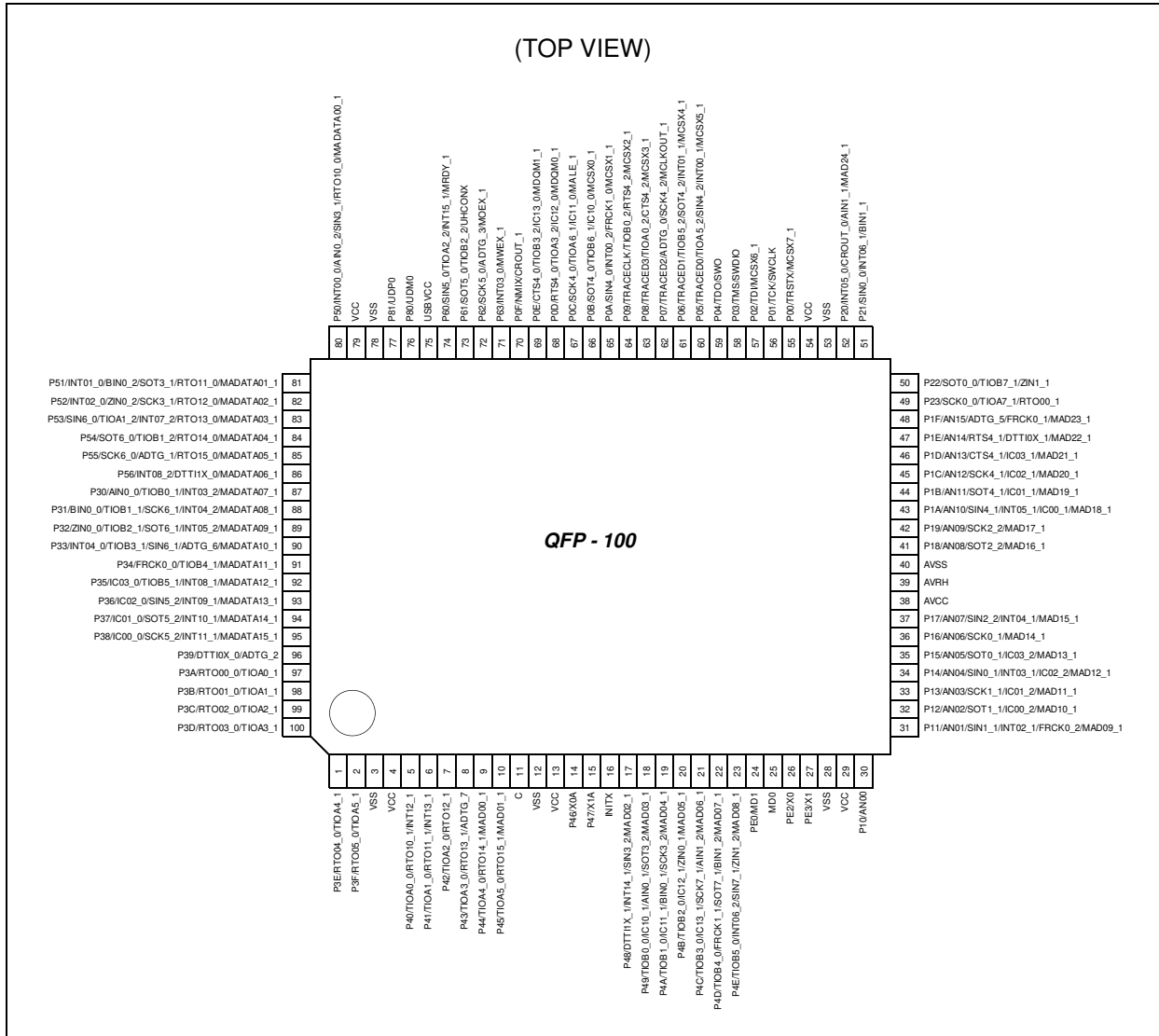

<Note>

The number after the underscore ("_") in pin names such as XXX_1 and XXX_2 indicates the relocated port number. For these pins, there are multiple pins that provide the same function for the same channel. Use the extended port function register (EPFR) to select the pin.

MB9A310A Series

• FPT-80P-M21/FPT-80P-M37

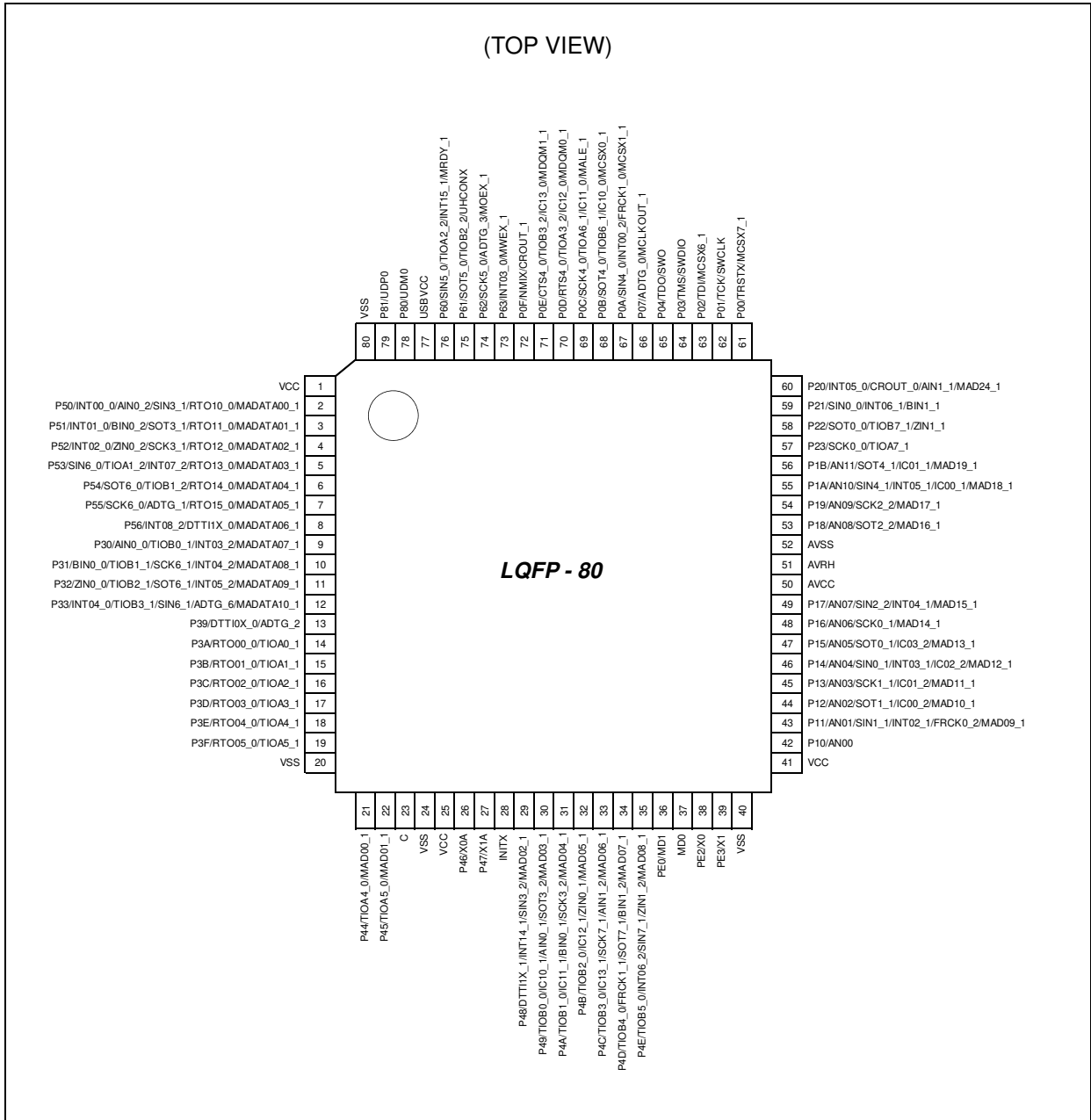

<Note>

The number after the underscore ("_") in pin names such as XXX_1 and XXX_2 indicates the relocated port number. For these pins, there are multiple pins that provide the same function for the same channel. Use the extended port function register (EPFR) to select the pin.

• FPT-64P-M23/M24/M38/M39

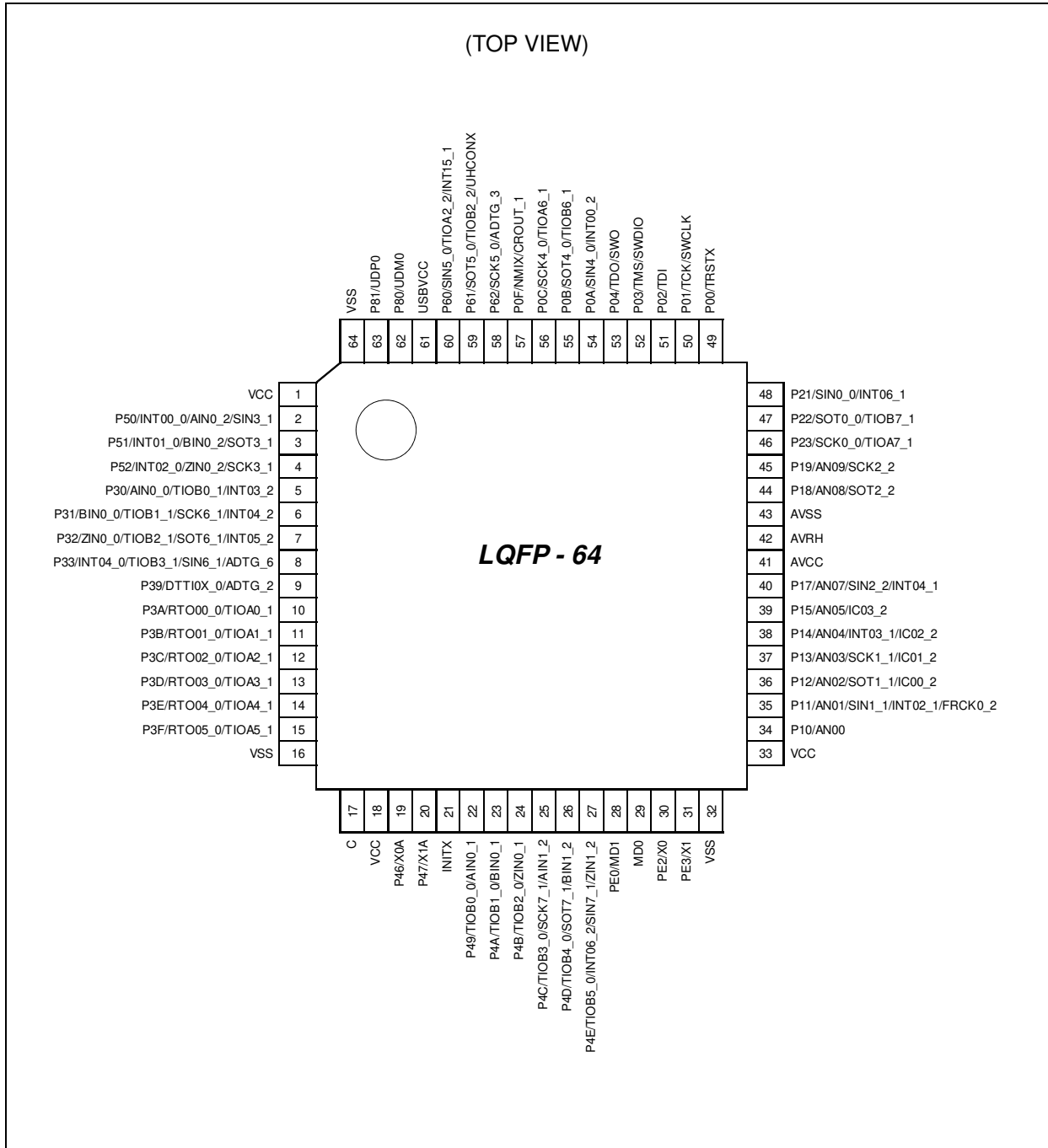

<Note>

The number after the underscore ("_") in pin names such as XXX_1 and XXX_2 indicates the relocated port number. For these pins, there are multiple pins that provide the same function for the same channel. Use the extended port function register (EPFR) to select the pin.

MB9A310A Series

· BGA-112P-M04

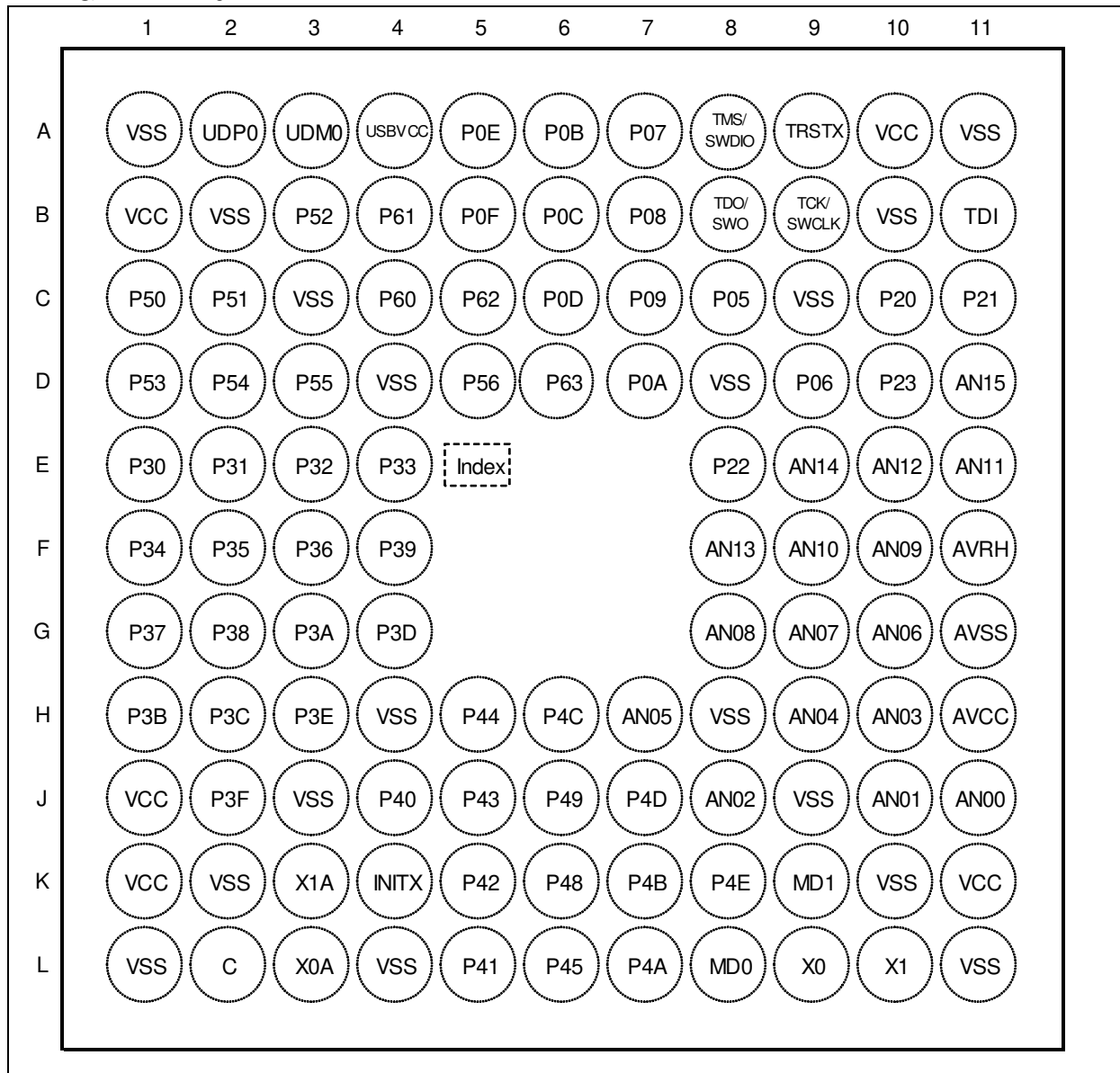

<Note>

The number after the underscore ("_") in pin names such as XXX_1 and XXX_2 indicates the relocated port number. For these pins, there are multiple pins that provide the same function for the same channel. Use the extended port function register (EPFR) to select the pin.

· LCC-64P-M24

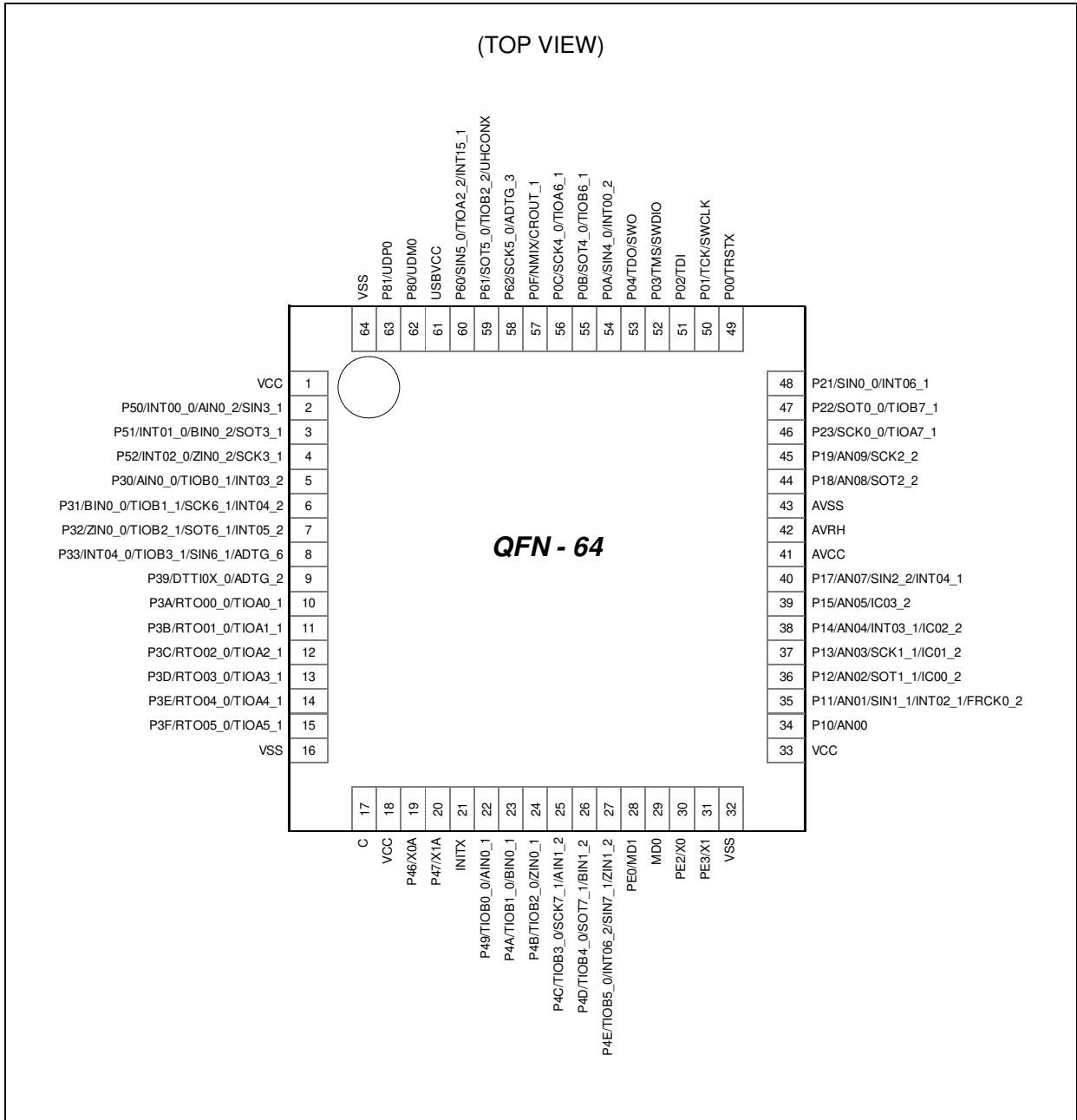

<Note>

The number after the underscore ("_") in pin names such as XXX_1 and XXX_2 indicates the relocated port number. For these pins, there are multiple pins that provide the same function for the same channel. Use the extended port function register (EPFR) to select the pin.

MB9A310A Series

■ PIN DESCRIPTION

The number after the underscore ("_") in pin names such as XXX_1 and XXX_2 indicates the relocated port number. For these pins, there are multiple pins that provide the same function for the same channel. Use the extended port function register (EPFR) to select the pin.

Pin No					Pin name	I/O circuit type	Pin state type
LQFP-100	QFP-100	BGA-112	LQFP-80	LQFP-64 QFN-64			
1	79	B1	1	1	VCC	-	
2	80	C1	2	2	P50	E	H
					INT00_0		
					AIN0_2		
				SIN3_1			
				-	RTO10_0 (PPG10_0)		
MADATA00_1							
3	81	C2	3	3	P51	E	H
					INT01_0		
					BIN0_2		
				SOT3_1 (SDA3_1)			
				-	RTO11_0 (PPG10_0)		
MADATA01_1							
4	82	B3	4	4	P52	E	H
					INT02_0		
					ZIN0_2		
				SCK3_1 (SCL3_1)			
				-	RTO12_0 (PPG12_0)		
MADATA02_1							
5	83	D1	5	-	P53	E	H
					SIN6_0		
					TIOA1_2		
					INT07_2		
					RTO13_0 (PPG12_0)		
MADATA03_1							
6	84	D2	6	-	P54	E	I
					SOT6_0 (SDA6_0)		
					TIOB1_2		
					RTO14_0 (PPG14_0)		
					MADATA04_1		

MB9A310A Series

Pin No					Pin name	I/O circuit type	Pin state type
LQFP-100	QFP-100	BGA-112	LQFP-80	LQFP-64 QFN-64			
7	85	D3	7	-	P55	E	I
					SCK6_0 (SCL6_0)		
					ADTG_1		
					RTO15_0 (PPG14_0)		
					MADATA05_1		
8	86	D5	8	-	P56	E	H
					INT08_2		
					DTT11X_0		
					MADATA06_1		
9	87	E1	9	5	P30	E	H
					AIN0_0		
					TIOB0_1		
				INT03_2			
				-	MADATA07_1		
10	88	E2	10	6	P31	E	H
					BIN0_0		
					TIOB1_1		
					SCK6_1 (SCL6_1)		
				INT04_2			
				-	MADATA08_1		
11	89	E3	11	7	P32	E	H
					ZIN0_0		
					TIOB2_1		
					SOT6_1 (SDA6_1)		
				INT05_2			
				-	MADATA09_1		
12	90	E4	12	8	P33	E	H
					INT04_0		
					TIOB3_1		
					SIN6_1		
				ADTG_6			
				-	MADATA10_1		
13	91	F1	-	-	P34	E	I
					FRCK0_0		
					TIOB4_1		
					MADATA11_1		

MB9A310A Series

Pin No					Pin name	I/O circuit type	Pin state type
LQFP-100	QFP-100	BGA-112	LQFP-80	LQFP-64 QFN-64			
14	92	F2	-	-	P35	E	H
					IC03_0		
					TIOB5_1		
					INT08_1		
					MADATA12_1		
15	93	F3	-	-	P36	E	H
					IC02_0		
					SIN5_2		
					INT09_1		
					MADATA13_1		
16	94	G1	-	-	P37	E	H
					IC01_0		
					SOT5_2 (SDA5_2)		
					INT10_1		
					MADATA14_1		
17	95	G2	-	-	P38	E	H
					IC00_0		
					SCK5_2 (SCL5_2)		
					INT11_1		
					MADATA15_1		
18	96	F4	13	9	P39	E	I
					DTTIOX_0		
					ADTG_2		
19	97	G3	14	10	P3A	G	I
					RTO00_0 (PPG00_0)		
					TIOA0_1		
20	98	H1	15	11	P3B	G	I
					RTO01_0 (PPG00_0)		
					TIOA1_1		
21	99	H2	16	12	P3C	G	I
					RTO02_0 (PPG02_0)		
					TIOA2_1		
22	100	G4	17	13	P3D	G	I
					RTO03_0 (PPG02_0)		
					TIOA3_1		
-	-	B2	-	-	VSS	-	-

MB9A310A Series

Pin No					Pin name	I/O circuit type	Pin state type
LQFP-100	QFP-100	BGA-112	LQFP-80	LQFP-64 QFN-64			
23	1	H3	18	14	P3E	G	I
					RTO04_0 (PPG04_0)		
					TIOA4_1		
24	2	J2	19	15	P3F	G	I
					RTO05_0 (PPG04_0)		
					TIOA5_1		
25	3	L1	20	16	VSS	-	-
26	4	J1	-	-	VCC	-	-
27	5	J4	-	-	P40	G	H
					TIOA0_0		
					RTO10_1 (PPG10_1)		
					INT12_1		
28	6	L5	-	-	P41	G	H
					TIOA1_0		
					RTO11_1 (PPG10_1)		
					INT13_1		
29	7	K5	-	-	P42	G	I
					TIOA2_0		
					RTO12_1 (PPG12_1)		
30	8	J5	-	-	P43	G	I
					TIOA3_0		
					RTO13_1 (PPG12_1)		
					ADTG_7		
31	9	H5	21	-	P44	G	I
			-		TIOA4_0		
			-		MAD00_1		
32	10	L6	22	-	P45	G	I
			-		TIOA5_0		
			-		MAD01_1		
			-		RTO15_1 (PPG14_1)		
-	-	K2	-	-	VSS	-	-
-	-	J3	-	-	VSS	-	-
-	-	H4	-	-	VSS	-	-

MB9A310A Series

Pin No					Pin name	I/O circuit type	Pin state type
LQFP-100	QFP-100	BGA-112	LQFP-80	LQFP-64 QFN-64			
33	11	L2	23	17	C	-	
34	12	L4	24	-	VSS	-	
35	13	K1	25	18	VCC	-	
36	14	L3	26	19	P46	D	M
					X0A		
37	15	K3	27	20	P47	D	N
					X1A		
38	16	K4	28	21	INITX	B	C
39	17	K6	29	-	P48	E	H
					DTT1X_1		
					INT14_1		
					SIN3_2		
					MAD02_1		
40	18	J6	30	22	P49	E	I
					TIOB0_0		
				AIN0_1			
				-	IC10_1		
					SOT3_2 (SDA3_2)		
MAD03_1							
41	19	L7	31	23	P4A	E	I
					TIOB1_0		
				BIN0_1			
				-	IC11_1		
					SCK3_2 (SCL3_2)		
MAD04_1							
42	20	K7	32	24	P4B	E	I
					TIOB2_0		
				ZIN0_1			
				-	IC12_1		
MAD05_1							
43	21	H6	33	25	P4C	E / I*	I
					TIOB3_0		
					SCK7_1 (SCL7_1)		
					AIN1_2		
				-	IC13_1		
					MAD06_1		

MB9A310A Series

Pin No					Pin name	I/O circuit type	Pin state type
LQFP-100	QFP-100	BGA-112	LQFP-80	LQFP-64 QFN-64			
44	22	J7	34	26	P4D	E / I*	I
					TIOB4_0		
					SOT7_1 (SDA7_1)		
				-	BIN1_2		
					FRCK1_1		
					MAD07_1		
45	23	K8	35	27	P4E	E / I*	I
					TIOB5_0		
					INT06_2		
				-	SIN7_1		
					ZIN1_2		
					MAD08_1		
46	24	K9	36	28	MD1	C	P
					PE0		
47	25	L8	37	29	MD0	J	D
48	26	L9	38	30	X0	A	A
					PE2		
49	27	L10	39	31	X1	A	B
					PE3		
50	28	L11	40	32	VSS	-	
51	29	K11	41	33	VCC	-	
52	30	J11	42	34	P10	F	K
					AN00		
53	31	J10	43	35	P11	F	L
					AN01		
					SIN1_1		
				-	INT02_1		
					FRCK0_2		
					MAD09_1		
54	32	J8	44	36	P12	F	K
					AN02		
					SOT1_1 (SDA1_1)		
				-	IC00_2		
					MAD10_1		
-	-	K10	-	-	VSS	-	
-	-	J9	-	-	VSS	-	

MB9A310A Series

Pin No					Pin name	I/O circuit type	Pin state type	
LQFP-100	QFP-100	BGA-112	LQFP-80	LQFP-64 QFN-64				
55	33	H10	45	37	P13	F	K	
					AN03			
					SCK1_1 (SCL1_1)			
					IC01_2			
-	-	-	-	-	MAD11_1	-	-	
56	34	H9	46	38	P14	F	L	
					AN04			
					INT03_1			
					IC02_2			
					-			SIN0_1
					-			MAD12_1
57	35	H7	47	39	P15	F	K	
					AN05			
					IC03_2			
					-			SOT0_1 (SDA0_1)
					-			MAD13_1
58	36	G10	48	-	P16	F	K	
					AN06			
					SCK0_1 (SCL0_1)			
					MAD14_1			
59	37	G9	49	40	P17	F	L	
					AN07			
					SIN2_2			
					INT04_1			
					-			MAD15_1
60	38	H11	50	41	AVCC	-	-	
61	39	F11	51	42	AVRH	-	-	
62	40	G11	52	43	AVSS	-	-	
63	41	G8	53	44	P18	F	K	
					AN08			
					SOT2_2 (SDA2_2)			
					-			MAD16_1
64	42	F10	54	45	P19	F	K	
					AN09			
					SCK2_2 (SCL2_2)			
					-			MAD17_1
					-			VSS
-	-	H8	-	-	-	-	-	

MB9A310A Series

Pin No					Pin name	I/O circuit type	Pin state type
LQFP-100	QFP-100	BGA-112	LQFP-80	LQFP-64 QFN-64			
65	43	F9	55	-	P1A	F	L
					AN10		
					SIN4_1		
					INT05_1		
					IC00_1		
					MAD18_1		
66	44	E11	56	-	P1B	F	K
					AN11		
					SOT4_1 (SDA4_1)		
					IC01_1		
					MAD19_1		
67	45	E10	-	-	P1C	F	K
					AN12		
					SCK4_1 (SCL4_1)		
					IC02_1		
					MAD20_1		
68	46	F8	-	-	P1D	F	K
					AN13		
					CTS4_1		
					IC03_1		
					MAD21_1		
69	47	E9	-	-	P1E	F	K
					AN14		
					RTS4_1		
					DTTIOX_1		
					MAD22_1		
70	48	D11	-	-	P1F	F	K
					AN15		
					ADTG_5		
					FRCK0_1		
					MAD23_1		
-	-	B10	-	-	VSS	-	-
-	-	C9	-	-	VSS	-	-

MB9A310A Series

Pin No					Pin name	I/O circuit type	Pin state type
LQFP-100	QFP-100	BGA-112	LQFP-80	LQFP-64 QFN-64			
71	49	D10	57	46	P23	E	I
					SCK0_0 (SCL0_0)		
			TIOA7_1				
			-	-	RTO00_1 (PPG00_1)		
72	50	E8	58	47	P22	E	I
					SOT0_0 (SDA0_0)		
					TIOB7_1		
				-	ZIN1_1		
73	51	C11	59	48	P21	E	H
					SIN0_0		
					INT06_1		
				-	BIN1_1		
74	52	C10	60	-	P20	E	H
					INT05_0		
					CROUT_0		
					AIN1_1		
					MAD24_1		
75	53	A11	-	-	VSS	-	
76	54	A10	-	-	VCC	-	
77	55	A9	61	49	P00	E	E
					TRSTX		
				-	MCSX7_1		
78	56	B9	62	50	P01	E	E
					TCK		
					SWCLK		
79	57	B11	63	51	P02	E	E
					TDI		
					MCSX6_1		
80	58	A8	64	52	P03	E	E
					TMS		
					SWDIO		
81	59	B8	65	53	P04	E	E
					TDO		
					SWO		
82	60	C8	-	-	P05	E	F
					TRACED0		
					TIOA5_2		
					SIN4_2		
					INT00_1		
MCSX5_1							
-	-	D8	-	-	VSS	-	

MB9A310A Series

Pin No					Pin name	I/O circuit type	Pin state type
LQFP-100	QFP-100	BGA-112	LQFP-80	LQFP-64 QFN-64			
83	61	D9	-	-	P06	E	F
					TRACED1		
					TIOB5_2		
					SOT4_2 (SDA4_2)		
					INT01_1 MCSX4_1		
84	62	A7	66	-	P07	E	G
			-		ADTG_0		
			-		MCLKOUT_1		
			-		TRACED2 SCK4_2 (SCL4_2)		
85	63	B7	-	-	P08	E	G
					TRACED3		
					TIOA0_2		
					CTS4_2 MCSX3_1		
86	64	C7	-	-	P09	E	G
					TRACECLK		
					TIOB0_2		
					RTS4_2 MCSX2_1		
87	65	D7	67	54	E / I*	H	
				-			P0A
				-			SIN4_0
				-			INT00_2 FRCK1_0 MCSX1_1
88	66	A6	68	55	E / I*	I	
				-			P0B
				-			SOT4_0 (SDA4_0)
				-			TIOB6_1 IC10_0 MCSX0_1
89	67	B6	69	56	E / I*	I	
				-			P0C
				-			SCK4_0 (SCL4_0)
				-			TIOA6_1 IC11_0 MALE_1
-	-	D4	-	-	VSS	-	
-	-	C3	-	-	VSS	-	

MB9A310A Series

Pin No					Pin name	I/O circuit type	Pin state type
LQFP-100	QFP-100	BGA-112	LQFP-80	LQFP-64 QFN-64			
90	68	C6	70	-	P0D	E	I
					RTS4_0		
					TIOA3_2		
					IC12_0		
					MDQM0_1		
91	69	A5	71	-	P0E	E	I
					CTS4_0		
					TIOB3_2		
					IC13_0		
					MDQM1_1		
92	70	B5	72	57	P0F	E	J
					NMIX		
					CROUT_1		
93	71	D6	73	-	P63	E	H
					INT03_0		
					MWEX_1		
94	72	C5	74	58	P62	E	I
					SCK5_0 (SCL5_0)		
				ADTG_3			
				-	MOEX_1		
95	73	B4	75	59	P61	E	I
					SOT5_0 (SDA5_0)		
					TIOB2_2		
					UHCONX		
96	74	C4	76	60	P60	E / I*	H
					SIN5_0		
					TIOA2_2		
				-	INT15_1		
				-	MRDY_1		
97	75	A4	77	61	USBVCC	-	
98	76	A3	78	62	P80	H	O
					UDM0		
99	77	A2	79	63	P81	H	O
					UDP0		
100	78	A1	80	64	VSS	-	

*: 5V tolerant I/O on MB9AF315MA/NA, MB9AF316MA/NA.

■ SIGNAL DESCRIPTION

The number after the underscore ("_") in pin names such as XXX_1 and XXX_2 indicates the relocated port number. For these pins, there are multiple pins that provide the same function for the same channel. Use the extended port function register (EPFR) to select the pin.

Module	Pin name	Function	Pin No						
			LQFP-100	QFP-100	BGA-112	LQFP-80	LQFP-64 QFN-64		
ADC	ADTG_0	A/D converter external trigger input pin	84	62	A7	66	-		
	ADTG_1		7	85	D3	7	-		
	ADTG_2		18	96	F4	13	9		
	ADTG_3		94	72	C5	74	58		
	ADTG_4		-	-	-	-	-		
	ADTG_5		70	48	D11	-	-		
	ADTG_6		12	90	E4	12	8		
	ADTG_7		30	8	J5	-	-		
	ADTG_8		-	-	-	-	-		
	AN00		A/D converter analog input pin ANxx describes ADC ch.xx.	52	30	J11	42	34	
	AN01	53		31	J10	43	35		
	AN02	54		32	J8	44	36		
	AN03	55		33	H10	45	37		
	AN04	56		34	H9	46	38		
	AN05	57		35	H7	47	39		
	AN06	58		36	G10	48	-		
	AN07	59		37	G9	49	40		
	AN08	63		41	G8	53	44		
	AN09	64		42	F10	54	45		
	AN10	65		43	F9	55	-		
	AN11	66		44	E11	56	-		
	AN12	67		45	E10	-	-		
	AN13	68		46	F8	-	-		
	AN14	69		47	E9	-	-		
	AN15	70		48	D11	-	-		
	Base Timer 0	TIOA0_0		Base timer ch.0 TIOA pin	27	5	J4	-	-
		TIOA0_1			19	97	G3	14	10
		TIOA0_2	85		63	B7	-	-	
TIOB0_0		Base timer ch.0 TIOB pin	40	18	J6	30	22		
TIOB0_1			9	87	E1	9	5		
TIOB0_2			86	64	C7	-	-		
Base Timer 1	TIOA1_0	Base timer ch.1 TIOA pin	28	6	L5	-	-		
	TIOA1_1		20	98	H1	15	11		
	TIOA1_2		5	83	D1	5	-		
	TIOB1_0	Base timer ch.1 TIOB pin	41	19	L7	31	23		
	TIOB1_1		10	88	E2	10	6		
	TIOB1_2		6	84	D2	6	-		
Base Timer 2	TIOA2_0	Base timer ch.2 TIOA pin	29	7	K5	-	-		
	TIOA2_1		21	99	H2	16	12		
	TIOA2_2		96	74	C4	76	60		
	TIOB2_0	Base timer ch.2 TIOB pin	42	20	K7	32	24		
	TIOB2_1		11	89	E3	11	7		
	TIOB2_2		95	73	B4	75	59		

MB9A310A Series

Module	Pin name	Function	Pin No				
			LQFP-100	QFP-100	BGA-112	LQFP-80	LQFP-64 QFN-64
Base Timer 3	TIOA3_0	Base timer ch.3 TIOA pin	30	8	J5	-	-
	TIOA3_1		22	100	G4	17	13
	TIOA3_2		90	68	C6	70	-
	TIOB3_0	Base timer ch.3 TIOB pin	43	21	H6	33	25
	TIOB3_1		12	90	E4	12	8
	TIOB3_2		91	69	A5	71	-
Base Timer 4	TIOA4_0	Base timer ch.4 TIOA pin	31	9	H5	21	-
	TIOA4_1		23	1	H3	18	14
	TIOA4_2		-	-	-	-	-
	TIOB4_0	Base timer ch.4 TIOB pin	44	22	J7	34	26
	TIOB4_1		13	91	F1	-	-
	TIOB4_2		-	-	-	-	-
Base Timer 5	TIOA5_0	Base timer ch.5 TIOA pin	32	10	L6	22	-
	TIOA5_1		24	2	J2	19	15
	TIOA5_2		82	60	C8	-	-
	TIOB5_0	Base timer ch.5 TIOB pin	45	23	K8	35	27
	TIOB5_1		14	92	F2	-	-
	TIOB5_2		83	61	D9	-	-
Base Timer 6	TIOA6_1	Base timer ch.6 TIOA pin	89	67	B6	69	56
	TIOB6_1	Base timer ch.6 TIOB pin	88	66	A6	68	55
Base Timer 7	TIOA7_0	Base timer ch.7 TIOA pin	-	-	-	-	-
	TIOA7_1		71	49	D10	57	46
	TIOA7_2		-	-	-	-	-
	TIOB7_0	Base timer ch.7 TIOB pin	-	-	-	-	-
	TIOB7_1		72	50	E8	58	47
	TIOB7_2		-	-	-	-	-

MB9A310A Series

Module	Pin name	Function	Pin No				
			LQFP-100	QFP-100	BGA-112	LQFP-80	LQFP-64 QFN-64
Debugger	SWCLK	Serial wire debug interface clock input	78	56	B9	62	50
	SWDIO	Serial wire debug interface data input / output	80	58	A8	64	52
	SWO	Serial wire viewer output	81	59	B8	65	53
	TCK	J-TAG test clock input	78	56	B9	62	50
	TDI	J-TAG test data input	79	57	B11	63	51
	TDO	J-TAG debug data output	81	59	B8	65	53
	TMS	J-TAG test mode state input/output	80	58	A8	64	52
	TRACECLK	Trace CLK output of ETM	86	64	C7	-	-
	TRACED0	Trace data output of ETM	82	60	C8	-	-
	TRACED1		83	61	D9	-	-
	TRACED2		84	62	A7	-	-
	TRACED3		85	63	B7	-	-
	TRSTX	J-TAG test reset Input	77	55	A9	61	49
	External Bus	MAD00_1	External bus interface address bus	31	9	H5	21
MAD01_1		32		10	L6	22	-
MAD02_1		39		17	K6	29	-
MAD03_1		40		18	J6	30	-
MAD04_1		41		19	L7	31	-
MAD05_1		42		20	K7	32	-
MAD06_1		43		21	H6	33	-
MAD07_1		44		22	J7	34	-
MAD08_1		45		23	K8	35	-
MAD09_1		53		31	J10	43	-
MAD10_1		54		32	J8	44	-
MAD11_1		55		33	H10	45	-
MAD12_1		56		34	H9	46	-
MAD13_1		57		35	H7	47	-
MAD14_1		58		36	G10	48	-
MAD15_1		59		37	G9	49	-
MAD16_1		63		41	G8	53	-
MAD17_1		64		42	F10	54	-
MAD18_1		65		43	F9	55	-
MAD19_1		66		44	E11	56	-
MAD20_1		67		45	E10	-	-
MAD21_1		68		46	F8	-	-
MAD22_1		69		47	E9	-	-
MAD23_1		70		48	D11	-	-
MAD24_1	74	52	C10	60	-		

MB9A310A Series

Module	Pin name	Function	Pin No				
			LQFP-100	QFP-100	BGA-112	LQFP-80	LQFP-64 QFN-64
External Bus	MCSX0_1	External bus interface chip select output pin	88	66	A6	68	-
	MCSX1_1		87	65	D7	67	-
	MCSX2_1		86	64	C7	-	-
	MCSX3_1		85	63	B7	-	-
	MCSX4_1		83	61	D9	-	-
	MCSX5_1		82	60	C8	-	-
	MCSX6_1		79	57	B11	63	-
	MCSX7_1		77	55	A9	61	-
	MDQM0_1	External bus interface byte mask signal output	90	68	C6	70	-
	MDQM1_1		91	69	A5	71	-
	MOEX_1	External bus interface read enable signal for SRAM	94	72	C5	74	-
	MWEX_1	External bus interface write enable signal for SRAM	93	71	D6	73	-
	MADATA00_1	External bus interface data bus	2	80	C1	2	-
	MADATA01_1		3	81	C2	3	-
	MADATA02_1		4	82	B3	4	-
	MADATA03_1		5	83	D1	5	-
	MADATA04_1		6	84	D2	6	-
	MADATA05_1		7	85	D3	7	-
	MADATA06_1		8	86	D5	8	-
	MADATA07_1		9	87	E1	9	-
	MADATA08_1		10	88	E2	10	-
	MADATA09_1		11	89	E3	11	-
	MADATA10_1		12	90	E4	12	-
	MADATA11_1		13	91	F1	-	-
	MADATA12_1		14	92	F2	-	-
	MADATA13_1		15	93	F3	-	-
	MADATA14_1		16	94	G1	-	-
MADATA15_1	17		95	G2	-	-	
MALE_1	Address Latch enable signal for multiplex		89	67	B6	69	-
MRDY_1	External RDY input signal	96	74	C4	76	-	
MCLKOUT_1	External bus clock output	84	62	A7	66	-	

MB9A310A Series

Module	Pin name	Function	Pin No				
			LQFP-100	QFP-100	BGA-112	LQFP-80	LQFP-64 QFN-64
External Interrupt	INT00_0	External interrupt request 00 input pin	2	80	C1	2	2
	INT00_1		82	60	C8	-	-
	INT00_2		87	65	D7	67	54
	INT01_0	External interrupt request 01 input pin	3	81	C2	3	3
	INT01_1		83	61	D9	-	-
	INT02_0	External interrupt request 02 input pin	4	82	B3	4	4
	INT02_1		53	31	J10	43	35
	INT03_0	External interrupt request 03 input pin	93	71	D6	73	-
	INT03_1		56	34	H9	46	38
	INT03_2		9	87	E1	9	5
	INT04_0	External interrupt request 04 input pin	12	90	E4	12	8
	INT04_1		59	37	G9	49	40
	INT04_2		10	88	E2	10	6
	INT05_0	External interrupt request 05 input pin	74	52	C10	60	-
	INT05_1		65	43	F9	55	-
	INT05_2		11	89	E3	11	7
	INT06_1	External interrupt request 06 input pin	73	51	C11	59	48
	INT06_2		45	23	K8	35	27
	INT07_2	External interrupt request 07 input pin	5	83	D1	5	-
	INT08_1	External interrupt request 08 input pin	14	92	F2	-	-
	INT08_2		8	86	D5	8	-
	INT09_1	External interrupt request 09 input pin	15	93	F3	-	-
	INT10_1	External interrupt request 10 input pin	16	94	G1	-	-
INT11_1	External interrupt request 11 input pin	17	95	G2	-	-	
INT12_1	External interrupt request 12 input pin	27	5	J4	-	-	
INT13_1	External interrupt request 13 input pin	28	6	L5	-	-	
INT14_1	External interrupt request 14 input pin	39	17	K6	29	-	
INT15_1	External interrupt request 15 input pin	96	74	C4	76	60	
NMIX	Non-Maskable Interrupt input	92	70	B5	72	57	

MB9A310A Series

Module	Pin name	Function	Pin No				
			LQFP-100	QFP-100	BGA-112	LQFP-80	LQFP-64 QFN-64
GPIO	P00	General-purpose I/O port 0	77	55	A9	61	49
	P01		78	56	B9	62	50
	P02		79	57	B11	63	51
	P03		80	58	A8	64	52
	P04		81	59	B8	65	53
	P05		82	60	C8	-	-
	P06		83	61	D9	-	-
	P07		84	62	A7	66	-
	P08		85	63	B7	-	-
	P09		86	64	C7	-	-
	P0A		87	65	D7	67	54
	P0B		88	66	A6	68	55
	P0C		89	67	B6	69	56
	P0D		90	68	C6	70	-
	P0E		91	69	A5	71	-
	P0F		92	70	B5	72	57
	P10	General-purpose I/O port 1	52	30	J11	42	34
	P11		53	31	J10	43	35
	P12		54	32	J8	44	36
	P13		55	33	H10	45	37
	P14		56	34	H9	46	38
	P15		57	35	H7	47	39
	P16		58	36	G10	48	-
	P17		59	37	G9	49	40
	P18		63	41	G8	53	44
	P19		64	42	F10	54	45
	P1A		65	43	F9	55	-
	P1B		66	44	E11	56	-
	P1C		67	45	E10	-	-
	P1D		68	46	F8	-	-
P1E	69	47	E9	-	-		
P1F	70	48	D11	-	-		
P20	General-purpose I/O port 2	74	52	C10	60	-	
P21		73	51	C11	59	48	
P22		72	50	E8	58	47	
P23		71	49	D10	57	46	

MB9A310A Series

Module	Pin name	Function	Pin No				
			LQFP-100	QFP-100	BGA-112	LQFP-80	LQFP-64 QFN-64
GPIO	P30	General-purpose I/O port 3	9	87	E1	9	5
	P31		10	88	E2	10	6
	P32		11	89	E3	11	7
	P33		12	90	E4	12	8
	P34		13	91	F1	-	-
	P35		14	92	F2	-	-
	P36		15	93	F3	-	-
	P37		16	94	G1	-	-
	P38		17	95	G2	-	-
	P39		18	96	F4	13	9
	P3A		19	97	G3	14	10
	P3B		20	98	H1	15	11
	P3C		21	99	H2	16	12
	P3D		22	100	G4	17	13
	P3E		23	1	H3	18	14
	P3F		24	2	J2	19	15
	P40	General-purpose I/O port 4	27	5	J4	-	-
	P41		28	6	L5	-	-
	P42		29	7	K5	-	-
	P43		30	8	J5	-	-
	P44		31	9	H5	21	-
	P45		32	10	L6	22	-
	P46		36	14	L3	26	19
	P47		37	15	K3	27	20
	P48		39	17	K6	29	-
	P49		40	18	J6	30	22
	P4A		41	19	L7	31	23
	P4B		42	20	K7	32	24
	P4C		43	21	H6	33	25
	P4D		44	22	J7	34	26
	P4E		45	23	K8	35	27
	P50		General-purpose I/O port 5	2	80	C1	2
	P51	3		81	C2	3	3
	P52	4		82	B3	4	4
	P53	5		83	D1	5	-
	P54	6		84	D2	6	-
	P55	7		85	D3	7	-
	P56	8		86	D5	8	-
	P60	General-purpose I/O port 6		96	74	C4	76
	P61		95	73	B4	75	59
	P62		94	72	C5	74	58
	P63		93	71	D6	73	-
P80	General-purpose I/O port 8	98	76	A3	78	62	
P81		99	77	A2	79	63	
PE0	General-purpose I/O port E	46	24	K9	36	28	
PE2		48	26	L9	38	30	
PE3		49	27	L10	39	31	

MB9A310A Series

Module	Pin name	Function	Pin No				
			LQFP-100	QFP-100	BGA-112	LQFP-80	LQFP-64 QFN-64
Multi Function Serial 0	SIN0_0	Multifunction serial interface ch.0 input pin	73	51	C11	59	48
	SIN0_1		56	34	H9	46	-
	SOT0_0 (SDA0_0)	Multifunction serial interface ch.0 output pin	72	50	E8	58	47
	SOT0_1 (SDA0_1)	This pin operates as SOT0 when it is used in a UART/CSIO/LIN (operation modes 0 to 3) and as SDA0 when it is used in an I ² C (operation mode 4).	57	35	H7	47	-
	SCK0_0 (SCL0_0)	Multifunction serial interface ch.0 clock I/O pin	71	49	D10	57	46
	SCK0_1 (SCL0_1)	This pin operates as SCK0 when it is used in a CSIO (operation modes 2) and as SCL0 when it is used in an I ² C (operation mode 4).	58	36	G10	48	-
Multi Function Serial 1	SIN1_1	Multifunction serial interface ch.1 input pin	53	31	J10	43	35
	SOT1_1 (SDA1_1)	Multifunction serial interface ch.1 output pin This pin operates as SOT1 when it is used in a UART/CSIO/LIN (operation modes 0 to 3) and as SDA1 when it is used in an I ² C (operation mode 4).	54	32	J8	44	36
	SCK1_1 (SCL1_1)	Multifunction serial interface ch.1 clock I/O pin This pin operates as SCK1 when it is used in a CSIO (operation modes 2) and as SCL1 when it is used in an I ² C (operation mode 4).	55	33	H10	45	37

MB9A310A Series

Module	Pin name	Function	Pin No				
			LQFP-100	QFP-100	BGA-112	LQFP-80	LQFP-64 QFN-64
Multi Function Serial 2	SIN2_2	Multifunction serial interface ch.2 input pin	59	37	G9	49	40
	SOT2_2 (SDA2_2)	Multifunction serial interface ch.2 output pin This pin operates as SOT2 when it is used in a UART/CSIO/LIN (operation modes 0 to 3) and as SDA2 when it is used in an I ² C (operation mode 4).	63	41	G8	53	44
	SCK2_2 (SCL2_2)	Multifunction serial interface ch.2 clock I/O pin This pin operates as SCK2 when it is used in a CSIO (operation modes 2) and as SCL2 when it is used in an I ² C (operation mode 4).	64	42	F10	54	45
Multi Function Serial 3	SIN3_1	Multifunction serial interface ch.3 input pin	2	80	C1	2	2
	SIN3_2		39	17	K6	29	-
	SOT3_1 (SDA3_1)	Multifunction serial interface ch.3 output pin This pin operates as SOT3 when it is used in a UART/CSIO/LIN (operation modes 0 to 3) and as SDA3 when it is used in an I ² C (operation mode 4).	3	81	C2	3	3
	SOT3_2 (SDA3_2)	This pin operates as SOT3 when it is used in a UART/CSIO/LIN (operation modes 0 to 3) and as SDA3 when it is used in an I ² C (operation mode 4).	40	18	J6	30	-
	SCK3_1 (SCL3_1)	Multifunction serial interface ch.3 clock I/O pin This pin operates as SCK3 when it is used in a CSIO (operation modes 2) and as SCL3 when it is used in an I ² C (operation mode 4).	4	82	B3	4	4
	SCK3_2 (SCL3_2)	This pin operates as SCK3 when it is used in a CSIO (operation modes 2) and as SCL3 when it is used in an I ² C (operation mode 4).	41	19	L7	31	-

MB9A310A Series

Module	Pin name	Function	Pin No				
			LQFP-100	QFP-100	BGA-112	LQFP-80	LQFP-64 QFN-64
Multi Function Serial 4	SIN4_0	Multifunction serial interface ch.4 input pin	87	65	D7	67	54
	SIN4_1		65	43	F9	55	-
	SIN4_2		82	60	C8	-	-
	SOT4_0 (SDA4_0)	Multifunction serial interface ch.4 output pin	88	66	A6	68	55
	SOT4_1 (SDA4_1)	This pin operates as SOT4 when it is used in a UART/CSIO/LIN (operation modes 0 to 3) and as SDA4 when it is used in an I ² C (operation mode 4).	66	44	E11	56	-
	SOT4_2 (SDA4_2)		83	61	D9	-	-
	SCK4_0 (SCL4_0)	Multifunction serial interface ch.4 clock I/O pin	89	67	B6	69	56
	SCK4_1 (SCL4_1)	This pin operates as SCK4 when it is used in a CSIO (operation modes 2) and as SCL4 when it is used in an I ² C (operation mode 4).	67	45	E10	-	-
	SCK4_2 (SCL4_2)		84	62	A7	-	-
	RTS4_0	Multifunction serial interface ch.4 RTS output pin	90	68	C6	70	-
	RTS4_1		69	47	E9	-	-
	RTS4_2		86	64	C7	-	-
	CTS4_0	Multifunction serial interface ch.4 CTS input pin	91	69	A5	71	-
	CTS4_1		68	46	F8	-	-
CTS4_2	85		63	B7	-	-	
Multi Function Serial 5	SIN5_0	Multifunction serial interface ch.5 input pin	96	74	C4	76	60
	SIN5_2		15	93	F3	-	-
	SOT5_0 (SDA5_0)	Multifunction serial interface ch.5 output pin	95	73	B4	75	59
	SOT5_2 (SDA5_2)	This pin operates as SOT5 when it is used in a UART/CSIO/LIN (operation modes 0 to 3) and as SDA5 when it is used in an I ² C (operation mode 4).	16	94	G1	-	-
	SCK5_0 (SCL5_0)		Multifunction serial interface ch.5 clock I/O pin	94	72	C5	74
	SCK5_2 (SCL5_2)	This pin operates as SCK5 when it is used in a CSIO (operation modes 2) and as SCL5 when it is used in an I ² C (operation mode 4).	17	95	G2	-	-

MB9A310A Series

Module	Pin name	Function	Pin No				
			LQFP-100	QFP-100	BGA-112	LQFP-80	LQFP-64 QFN-64
Multi Function Serial 6	SIN6_0	Multifunction serial interface ch.6 input pin	5	83	D1	5	-
	SIN6_1		12	90	E4	12	8
	SOT6_0 (SDA6_0)	Multifunction serial interface ch.6 output pin	6	84	D2	6	-
	SOT6_1 (SDA6_1)	This pin operates as SOT6 when it is used in a UART/CSIO/LIN (operation modes 0 to 3) and as SDA6 when it is used in an I ² C (operation mode 4).	11	89	E3	11	7
	SCK6_0 (SCL6_0)	Multifunction serial interface ch.6 clock I/O pin	7	85	D3	7	-
	SCK6_1 (SCL6_1)	This pin operates as SCK6 when it is used in a CSIO (operation modes 2) and as SCL6 when it is used in an I ² C (operation mode 4).	10	88	E2	10	6
Multi Function Serial 7	SIN7_1	Multifunction serial interface ch.7 input pin	45	23	K8	35	27
	SOT7_1 (SDA7_1)	Multifunction serial interface ch.7 output pin This pin operates as SOT7 when it is used in a UART/CSIO/LIN (operation modes 0 to 3) and as SDA7 when it is used in an I ² C (operation mode 4).	44	22	J7	34	26
	SCK7_1 (SCL7_1)	Multifunction serial interface ch.7 clock I/O pin This pin operates as SCK7 when it is used in a CSIO (operation modes 2) and as SCL7 when it is used in an I ² C (operation mode 4).	43	21	H6	33	25

MB9A310A Series

Module	Pin name	Function	Pin No					
			LQFP-100	QFP-100	BGA-112	LQFP-80	LQFP-64 QFN-64	
Multi Function Timer 0	DTTIOX_0	Input signal of wave form generator to control outputs RTO00 to RTO05 of multi-function timer 0	18	96	F4	13	9	
	DTTIOX_1		69	47	E9	-	-	
	FRCK0_0	16-bit free-run timer ch.0 external clock input pin	13	91	F1	-	-	
	FRCK0_1		70	48	D11	-	-	
	FRCK0_2		53	31	J10	43	35	
	IC00_0	16-bit input capture input pin of multi-function timer 0 ICxx describes channel number.	17	95	G2	-	-	
	IC00_1		65	43	F9	55	-	
	IC00_2		54	32	J8	44	36	
	IC01_0		16	94	G1	-	-	
	IC01_1		66	44	E11	56	-	
	IC01_2		55	33	H10	45	37	
	IC02_0		15	93	F3	-	-	
	IC02_1		67	45	E10	-	-	
	IC02_2		56	34	H9	46	38	
	IC03_0		14	92	F2	-	-	
	IC03_1		68	46	F8	-	-	
	IC03_2		57	35	H7	47	39	
	RTO00_0 (PPG00_0)		Wave form generator output of multi-function timer 0	19	97	G3	14	10
	RTO00_1 (PPG00_1)		This pin operates as PPG00 when it is used in PPG 0 output modes.	71	49	D10	-	-
	RTO01_0 (PPG00_0)	Wave form generator output of multi-function timer 0 This pin operates as PPG00 when it is used in PPG 0 output modes.	20	98	H1	15	11	
RTO02_0 (PPG02_0)	Wave form generator output of multi-function timer 0 This pin operates as PPG02 when it is used in PPG 0 output modes.	21	99	H2	16	12		
RTO03_0 (PPG02_0)	Wave form generator output of multi-function timer 0 This pin operates as PPG02 when it is used in PPG 0 output modes.	22	100	G4	17	13		
RTO04_0 (PPG04_0)	Wave form generator output of multi-function timer 0 This pin operates as PPG04 when it is used in PPG 0 output modes.	23	1	H3	18	14		
RTO05_0 (PPG04_0)	Wave form generator output of multi-function timer 0 This pin operates as PPG04 when it is used in PPG 0 output modes.	24	2	J2	19	15		

Module	Pin name	Function	Pin No					
			LQFP-100	QFP-100	BGA-112	LQFP-80	LQFP-64 QFN-64	
Multi Function Timer 1	DTT1X_0	Input signal of wave form generator to control outputs RTO10 to RTO15 of multi-function timer 1	8	86	D5	8	-	
	DTT1X_1		39	17	K6	29	-	
	FRCK1_0	16-bit free-run timer ch.1 external clock input pin	87	65	D7	67	-	
	FRCK1_1		44	22	J7	34	-	
	IC10_0	16-bit input capture input pin of multi-function timer 1 ICxx describes channel number.	88	66	A6	68	-	
	IC10_1		40	18	J6	30	-	
	IC11_0		89	67	B6	69	-	
	IC11_1		41	19	L7	31	-	
	IC12_0		90	68	C6	70	-	
	IC12_1		42	20	K7	32	-	
	IC13_0		91	69	A5	71	-	
	IC13_1		43	21	H6	33	-	
	RTO10_0 (PPG10_0)		Wave form generator output of multi-function timer 1	2	80	C1	2	-
	RTO10_1 (PPG10_1)		This pin operates as PPG10 when it is used in PPG 1 output modes.	27	5	J4	-	-
	RTO11_0 (PPG10_0)	Wave form generator output of multi-function timer 1	3	81	C2	3	-	
	RTO11_1 (PPG10_1)	This pin operates as PPG10 when it is used in PPG 1 output modes.	28	6	L5	-	-	
	RTO12_0 (PPG12_0)	Wave form generator output of multi-function timer 1	4	82	B3	4	-	
	RTO12_1 (PPG12_1)	This pin operates as PPG12 when it is used in PPG 1 output modes.	29	7	K5	-	-	
	RTO13_0 (PPG12_0)	Wave form generator output of multi-function timer 1	5	83	D1	5	-	
	RTO13_1 (PPG12_1)	This pin operates as PPG12 when it is used in PPG 1 output modes.	30	8	J5	-	-	
RTO14_0 (PPG14_0)	Wave form generator output of multi-function timer 1	6	84	D2	6	-		
RTO14_1 (PPG14_1)	This pin operates as PPG14 when it is used in PPG 1 output modes.	31	9	H5	21	-		
RTO15_0 (PPG14_0)	Wave form generator output of multi-function timer 1	7	85	D3	7	-		
RTO15_1 (PPG14_1)	This pin operates as PPG14 when it is used in PPG 1 output modes.	32	10	L6	22	-		

MB9A310A Series

Module	Pin name	Function	Pin No				
			LQFP-100	QFP-100	BGA-112	LQFP-80	LQFP-64 QFN-64
Quadrature Position/ Revolution Counter 0	AIN0_0	QPRC ch.0 AIN input pin	9	87	E1	9	5
	AIN0_1		40	18	J6	30	22
	AIN0_2		2	80	C1	2	2
	BIN0_0	QPRC ch.0 BIN input pin	10	88	E2	10	6
	BIN0_1		41	19	L7	31	23
	BIN0_2		3	81	C2	3	3
	ZIN0_0	QPRC ch.0 ZIN input pin	11	89	E3	11	7
	ZIN0_1		42	20	K7	32	24
	ZIN0_2		4	82	B3	4	4
Quadrature Position/ Revolution Counter 1	AIN1_1	QPRC ch.1 AIN input pin	74	52	C10	60	-
	AIN1_2		43	21	H6	33	25
	BIN1_1	QPRC ch.1 BIN input pin	73	51	C11	59	-
	BIN1_2		44	22	J7	34	26
	ZIN1_1	QPRC ch.1 ZIN input pin	72	50	E8	58	-
	ZIN1_2		45	23	K8	35	27
USB	UDM0	USB Function / HOST D – pin	98	76	A3	78	62
	UDP0	USB Function / HOST D + pin	99	77	A2	79	63
	UHCONX	USB external pull-up control pin	95	73	B4	75	59

MB9A310A Series

Module	Pin name	Function	Pin No				
			LQFP-100	QFP-100	BGA-112	LQFP-80	LQFP-64 QFN-64
RESET	INITX	External Reset Input. A reset is valid when INITX=L	38	16	K4	28	21
Mode	MD0	Mode 0 pin During normal operation, MD0=L must be input. During serial programming to flash memory, MD0=H must be input.	47	25	L8	37	29
	MD1	Mode 1 pin During serial programming to flash memory, MD1=L must be input.	46	24	K9	36	28
POWER	VCC	Power supply Pin	1	79	B1	1	1
	VCC	Power supply Pin	26	4	J1	-	-
	VCC	Power supply pin	35	13	K1	25	18
	VCC	Power supply pin	51	29	K11	41	33
	VCC	Power supply pin	76	54	A10	-	-
	USBVCC	3.3V Power supply port for USB I/O	97	75	A4	77	61
GND	VSS	GND Pin	-	-	B2	-	-
	VSS	GND pin	25	3	L1	20	16
	VSS	GND pin	-	-	K2	-	-
	VSS	GND pin	-	-	J3	-	-
	VSS	GND pin	-	-	H4	-	-
	VSS	GND pin	34	12	L4	24	-
	VSS	GND pin	50	28	L11	40	32
	VSS	GND pin	-	-	K10	-	-
	VSS	GND pin	-	-	J9	-	-
	VSS	GND pin	-	-	H8	-	-
	VSS	GND pin	-	-	B10	-	-
	VSS	GND pin	-	-	C9	-	-
	VSS	GND pin	75	53	A11	-	-
	VSS	GND pin	-	-	D8	-	-
	VSS	GND pin	-	-	D4	-	-
	VSS	GND pin	-	-	C3	-	-
VSS	GND pin	100	78	A1	80	64	
CLOCK	X0	Main clock (oscillation) input pin	48	26	L9	38	30
	X0A	Sub clock (oscillation) input pin	36	14	L3	26	19
	X1	Main clock (oscillation) I/O pin	49	27	L10	39	31
	X1A	Sub clock (oscillation) I/O pin	37	15	K3	27	20
	CROUT_0	Built-in high-speed CR-osc clock output port	74	52	C10	60	-
	CROUT_1		92	70	B5	72	57
ADC POWER	AVCC	A/D converter analog power supply pin	60	38	H11	50	41
	AVRH	A/D converter analog reference voltage input pin	61	39	F11	51	42
ADC GND	AVSS	A/D converter GND pin	62	40	G11	52	43
C pin	C	Power stabilization capacity pin	33	11	L2	23	17

MB9A310A Series

I/O CIRCUIT TYPE

Type	Circuit	Remarks
A		<ul style="list-style-type: none"> • It is possible to select the main oscillation / GPIO function <p>When the main oscillation is selected.</p> <ul style="list-style-type: none"> • Oscillation feedback resistor : Approximately 1MΩ • With Standby mode control <p>When the GPIO is selected.</p> <ul style="list-style-type: none"> • CMOS level output. • CMOS level hysteresis input • With pull-up resistor control • With standby mode control • Pull-up resistor : Approximately 50kΩ • $I_{OH} = -4mA, I_{OL} = 4mA$
B		<ul style="list-style-type: none"> • CMOS level hysteresis input • Pull-up resistor : Approximately 50kΩ

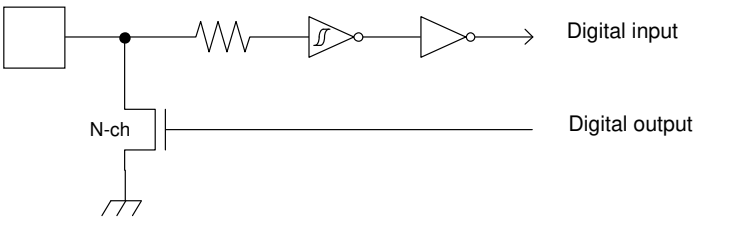
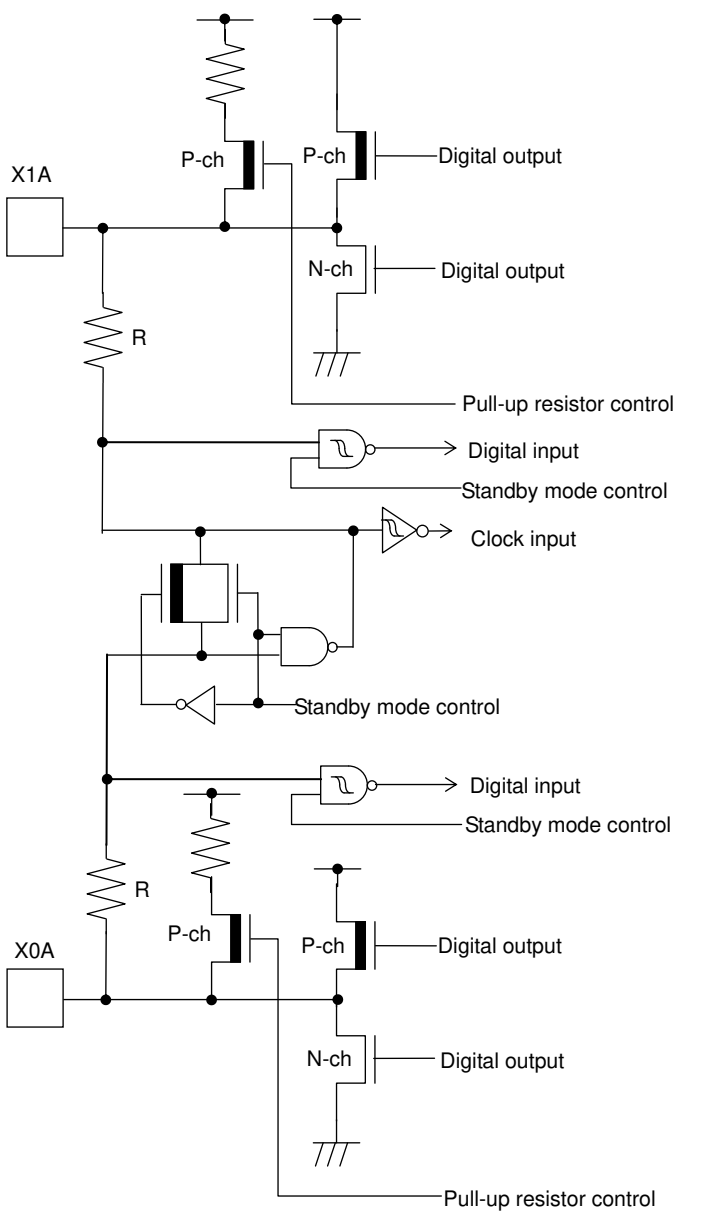
Type	Circuit	Remarks
C	 <p>The diagram shows a digital input pin connected to a pull-up resistor. The input signal passes through a CMOS level hysteresis input block and a buffer. The digital output is driven by an N-channel MOSFET connected to ground.</p>	<ul style="list-style-type: none"> • Open drain output • CMOS level hysteresis input
D	 <p>The diagram illustrates two oscillator sections, X1A and X0A, each with a pull-up resistor R. X1A includes a P-channel MOSFET for digital output, an N-channel MOSFET for digital output, a pull-up resistor control, a digital input, a standby mode control, and a clock input. X0A includes a P-channel MOSFET for digital output, an N-channel MOSFET for digital output, a pull-up resistor control, a digital input, and a standby mode control. Various logic gates and buffers are used to manage the signals.</p>	<ul style="list-style-type: none"> • It is possible to select the sub oscillation / GPIO function <p>When the sub oscillation is selected.</p> <ul style="list-style-type: none"> • Oscillation feedback resistor : Approximately 5MΩ • With Standby mode control <p>When the GPIO is selected.</p> <ul style="list-style-type: none"> • CMOS level output. • CMOS level hysteresis input • With pull-up resistor control • With standby mode control • Pull-up resistor : Approximately 50kΩ • $I_{OH} = -4mA$, $I_{OL} = 4mA$

MB9A310A Series

Type	Circuit	Remarks
E	<p>The circuit diagram for Type E shows a CMOS output stage. It consists of a P-channel MOSFET (P-ch) and an N-channel MOSFET (N-ch). The P-ch MOSFET's gate is connected to a digital input through an AND gate, which also receives a standby mode control signal. The P-ch MOSFET's source is connected to a pull-up resistor R, which is in turn connected to a digital input. The N-ch MOSFET's gate is connected to a digital input. The N-ch MOSFET's source is connected to ground. The output of the P-ch MOSFET is labeled 'Digital output'. The output of the N-ch MOSFET is also labeled 'Digital output'. A pull-up resistor control signal is connected to the gate of the N-ch MOSFET.</p>	<ul style="list-style-type: none"> • CMOS level output • CMOS level hysteresis input • With pull-up resistor control • With standby mode control • Pull-up resistor : Approximately 50kΩ • $I_{OH} = -4\text{mA}$, $I_{OL} = 4\text{mA}$
F	<p>The circuit diagram for Type F shows a CMOS output stage similar to Type E, but with additional features. It includes a P-channel MOSFET (P-ch) and an N-channel MOSFET (N-ch). The P-ch MOSFET's gate is connected to a digital input through an AND gate, which also receives a standby mode control signal. The N-ch MOSFET's gate is connected to a digital input. The output of the P-ch MOSFET is labeled 'Digital output'. The output of the N-ch MOSFET is also labeled 'Digital output'. A pull-up resistor R is connected to the P-ch MOSFET's source and to a digital input. A pull-up resistor control signal is connected to the gate of the N-ch MOSFET. An analog input is connected to the gate of the N-ch MOSFET through an AND gate, which also receives an input control signal. The output of this AND gate is connected to the gate of the N-ch MOSFET.</p>	<ul style="list-style-type: none"> • CMOS level output • CMOS level hysteresis input • With input control • Analog input • With pull-up resistor control • With standby mode control • Pull-up resistor : Approximately 50kΩ • $I_{OH} = -4\text{mA}$, $I_{OL} = 4\text{mA}$

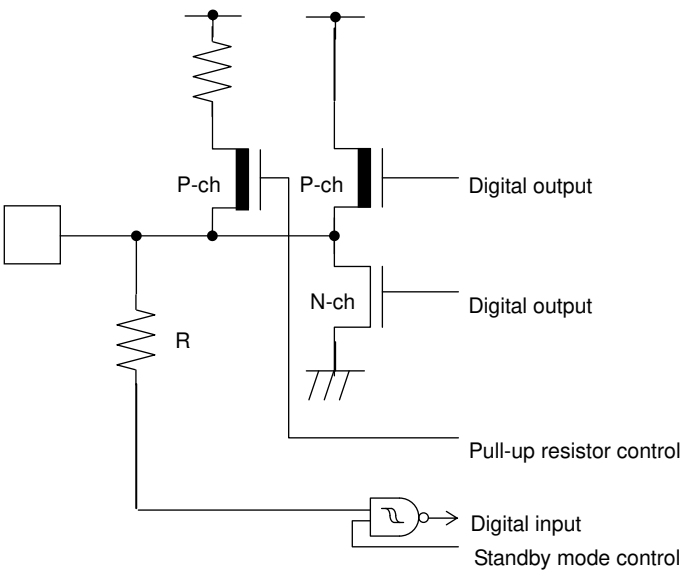
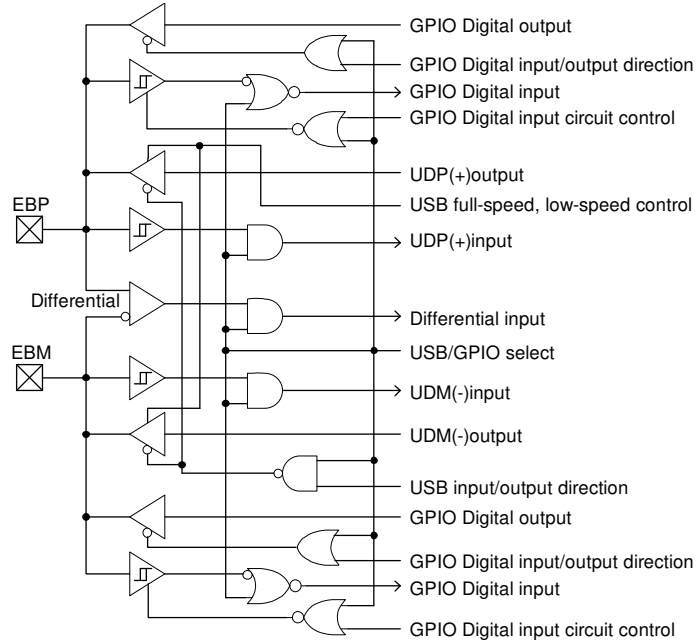
Type	Circuit	Remarks
G	 <p>The diagram shows a CMOS output stage. A P-channel MOSFET (P-ch) and an N-channel MOSFET (N-ch) are connected in a push-pull configuration. A pull-up resistor R is connected to the P-ch MOSFET gate. The N-ch MOSFET gate is connected to a pull-up resistor control input. The output of the P-ch MOSFET is labeled 'Digital output'. The output of the N-ch MOSFET is also labeled 'Digital output'. A digital input and a standby mode control input are connected to the gates of the P-ch and N-ch MOSFETs respectively.</p>	<ul style="list-style-type: none"> • CMOS level output • CMOS level hysteresis input • With pull-up resistor control • With standby mode control • Pull-up resistor : Approximately 50kΩ • $I_{OH} = -12\text{mA}$, $I_{OL} = 12\text{mA}$
H	 <p>The diagram shows a complex digital circuit with multiple inverters, AND gates, and OR gates. It includes control inputs EBP and EBM, and a Differential input. The outputs are labeled as follows: GPIO Digital output, GPIO Digital input/output direction, GPIO Digital input, GPIO Digital input circuit control, UDP(+)output, USB full-speed, low-speed control, UDP(+)input, Differential input, USB/GPIO select, UDM(-)input, UDM(-)output, USB input/output direction, GPIO Digital output, GPIO Digital input/output direction, GPIO Digital input, and GPIO Digital input circuit control.</p>	<ul style="list-style-type: none"> • It is possible to select the USB IO / GPIO function. <p>When the USB IO is selected.</p> <ul style="list-style-type: none"> • Full-speed, Low-speed control <p>When the GPIO is selected.</p> <ul style="list-style-type: none"> • CMOS level output • CMOS level hysteresis input • With standby mode control • $I_{OH} = -20.5\text{mA}$, $I_{OL} = 18.5\text{mA}$

MB9A310A Series

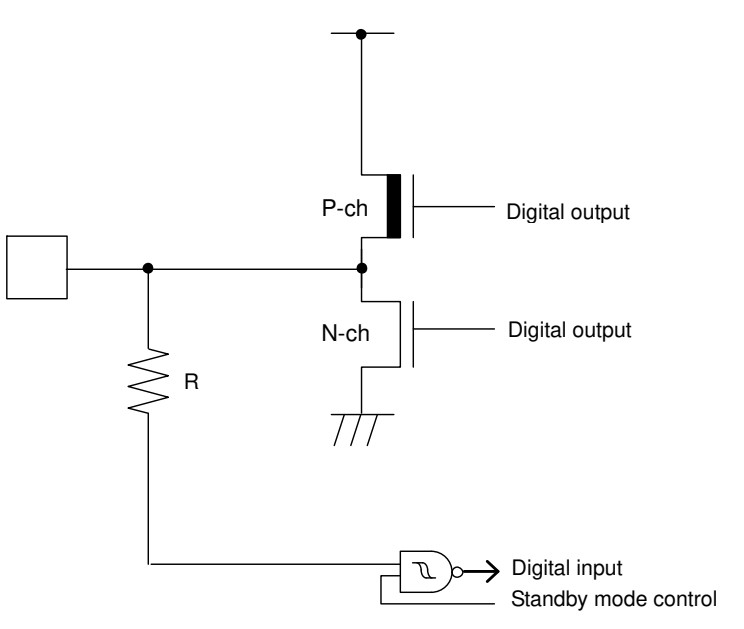
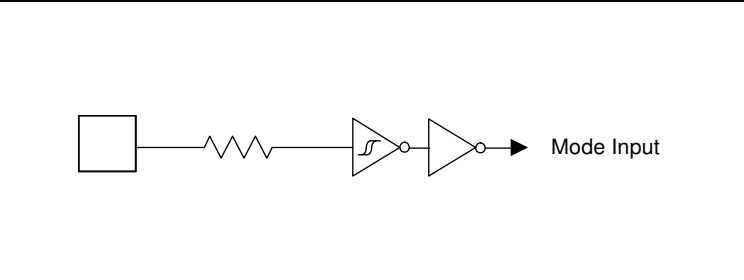
Type	Circuit	Remarks
I	 <p>The diagram shows a CMOS output stage. A pull-up resistor labeled 'R' is connected to the gate of a P-channel MOSFET (P-ch) and the gate of an N-channel MOSFET (N-ch). The P-ch MOSFET's source is connected to VDD and its drain is the 'Digital output'. The N-ch MOSFET's source is connected to ground and its drain is also the 'Digital output'. A digital input signal is connected to the gates of both MOSFETs. This input signal is also connected to a 'Standby mode control' block, which has a feedback loop from its output back to its input.</p>	<ul style="list-style-type: none"> • CMOS level output • CMOS level hysteresis input • 5V tolerant • With standby mode control • $I_{OH} = -4\text{mA}$, $I_{OL} = 4\text{mA}$
J	 <p>The diagram shows a CMOS level hysteresis input circuit. It consists of a pull-up resistor connected to a square wave input signal. The signal then passes through a hysteresis block (represented by a triangle with a feedback loop) and an inverter block, resulting in a 'Mode Input' signal.</p>	<p>CMOS level hysteresis input</p>

■ HANDLING PRECAUTIONS

Any semiconductor devices have inherently a certain rate of failure. The possibility of failure is greatly affected by the conditions in which they are used (circuit conditions, environmental conditions, etc.). This page describes precautions that must be observed to minimize the chance of failure and to obtain higher reliability from your FUJITSU SEMICONDUCTOR semiconductor devices.

1. Precautions for Product Design

This section describes precautions when designing electronic equipment using semiconductor devices.

• Absolute Maximum Ratings

Semiconductor devices can be permanently damaged by application of stress (voltage, current, temperature, etc.) in excess of certain established limits, called absolute maximum ratings. Do not exceed these ratings.

• Recommended Operating Conditions

Recommended operating conditions are normal operating ranges for the semiconductor device. All the device's electrical characteristics are warranted when operated within these ranges.

Always use semiconductor devices within the recommended operating conditions. Operation outside these ranges may adversely affect reliability and could result in device failure.

No warranty is made with respect to uses, operating conditions, or combinations not represented on the data sheet. Users considering application outside the listed conditions are advised to contact their sales representative beforehand.

• Processing and Protection of Pins

These precautions must be followed when handling the pins which connect semiconductor devices to power supply and input/output functions.

(1) Preventing Over-Voltage and Over-Current Conditions

Exposure to voltage or current levels in excess of maximum ratings at any pin is likely to cause deterioration within the device, and in extreme cases leads to permanent damage of the device. Try to prevent such overvoltage or over-current conditions at the design stage.

(2) Protection of Output Pins

Shorting of output pins to supply pins or other output pins, or connection to large capacitance can cause large current flows. Such conditions if present for extended periods of time can damage the device.

Therefore, avoid this type of connection.

(3) Handling of Unused Input Pins

Unconnected input pins with very high impedance levels can adversely affect stability of operation. Such pins should be connected through an appropriate resistance to a power supply pin or ground pin.

• Latch-up

Semiconductor devices are constructed by the formation of P-type and N-type areas on a substrate. When subjected to abnormally high voltages, internal parasitic PNP junctions (called thyristor structures) may be formed, causing large current levels in excess of several hundred mA to flow continuously at the power supply pin. This condition is called latch-up.

CAUTION: The occurrence of latch-up not only causes loss of reliability in the semiconductor device, but can cause injury or damage from high heat, smoke or flame. To prevent this from happening, do the following:

(1) Be sure that voltages applied to pins do not exceed the absolute maximum ratings. This should include attention to abnormal noise, surge levels, etc.

(2) Be sure that abnormal current flows do not occur during the power-on sequence.

- **Observance of Safety Regulations and Standards**

Most countries in the world have established standards and regulations regarding safety, protection from electromagnetic interference, etc. Customers are requested to observe applicable regulations and standards in the design of products.

- **Fail-Safe Design**

Any semiconductor devices have inherently a certain rate of failure. You must protect against injury, damage or loss from such failures by incorporating safety design measures into your facility and equipment such as redundancy, fire protection, and prevention of over-current levels and other abnormal operating conditions.

- **Precautions Related to Usage of Devices**

FUJITSU SEMICONDUCTOR semiconductor devices are intended for use in standard applications (computers, office automation and other office equipment, industrial, communications, and measurement equipment, personal or household devices, etc.).

CAUTION: Customers considering the use of our products in special applications where failure or abnormal operation may directly affect human lives or cause physical injury or property damage, or where extremely high levels of reliability are demanded (such as aerospace systems, atomic energy controls, sea floor repeaters, vehicle operating controls, medical devices for life support, etc.) are requested to consult with sales representatives before such use. The company will not be responsible for damages arising from such use without prior approval.

2. Precautions for Package Mounting

Package mounting may be either lead insertion type or surface mount type. In either case, for heat resistance during soldering, you should only mount under FUJITSU SEMICONDUCTOR's recommended conditions. For detailed information about mount conditions, contact your sales representative.

- **Lead Insertion Type**

Mounting of lead insertion type packages onto printed circuit boards may be done by two methods: direct soldering on the board, or mounting by using a socket.

Direct mounting onto boards normally involves processes for inserting leads into through-holes on the board and using the flow soldering (wave soldering) method of applying liquid solder. In this case, the soldering process usually causes leads to be subjected to thermal stress in excess of the absolute ratings for storage temperature. Mounting processes should conform to FUJITSU SEMICONDUCTOR recommended mounting conditions.

If socket mounting is used, differences in surface treatment of the socket contacts and IC lead surfaces can lead to contact deterioration after long periods. For this reason it is recommended that the surface treatment of socket contacts and IC leads be verified before mounting.

- **Surface Mount Type**

Surface mount packaging has longer and thinner leads than lead-insertion packaging, and therefore leads are more easily deformed or bent. The use of packages with higher pin counts and narrower pin pitch results in increased susceptibility to open connections caused by deformed pins, or shorting due to solder bridges.

You must use appropriate mounting techniques. FUJITSU SEMICONDUCTOR recommends the solder reflow method, and has established a ranking of mounting conditions for each product. Users are advised to mount packages in accordance with FUJITSU SEMICONDUCTOR ranking of recommended conditions.

- **Lead-Free Packaging**

CAUTION: When ball grid array (BGA) packages with Sn-Ag-Cu balls are mounted using Sn-Pb eutectic soldering, junction strength may be reduced under some conditions of use.

- **Storage of Semiconductor Devices**

Because plastic chip packages are formed from plastic resins, exposure to natural environmental conditions will cause absorption of moisture. During mounting, the application of heat to a package that has absorbed moisture can cause surfaces to peel, reducing moisture resistance and causing packages to crack. To prevent, do the following:

- (1) Avoid exposure to rapid temperature changes, which cause moisture to condense inside the product. Store products in locations where temperature changes are slight.
- (2) Use dry boxes for product storage. Products should be stored below 70% relative humidity, and at temperatures between 5°C and 30°C. When you open Dry Package that recommends humidity 40% to 70% relative humidity.
- (3) When necessary, FUJITSU SEMICONDUCTOR packages semiconductor devices in highly moisture-resistant aluminum laminate bags, with a silica gel desiccant. Devices should be sealed in their aluminum laminate bags for storage.
- (4) Avoid storing packages where they are exposed to corrosive gases or high levels of dust.

- **Baking**

Packages that have absorbed moisture may be de-moisturized by baking (heat drying). Follow the FUJITSU SEMICONDUCTOR recommended conditions for baking.

Condition: 125°C/24 h

- **Static Electricity**

Because semiconductor devices are particularly susceptible to damage by static electricity, you must take the following precautions:

- (1) Maintain relative humidity in the working environment between 40% and 70%. Use of an apparatus for ion generation may be needed to remove electricity.
- (2) Electrically ground all conveyors, solder vessels, soldering irons and peripheral equipment.
- (3) Eliminate static body electricity by the use of rings or bracelets connected to ground through high resistance (on the level of 1 MΩ). Wearing of conductive clothing and shoes, use of conductive floor mats and other measures to minimize shock loads is recommended.
- (4) Ground all fixtures and instruments, or protect with anti-static measures.
- (5) Avoid the use of styrofoam or other highly static-prone materials for storage of completed board assemblies.

3. Precautions for Use Environment

Reliability of semiconductor devices depends on ambient temperature and other conditions as described above.

For reliable performance, do the following:

(1) Humidity

Prolonged use in high humidity can lead to leakage in devices as well as printed circuit boards. If high humidity levels are anticipated, consider anti-humidity processing.

(2) Discharge of Static Electricity

When high-voltage charges exist close to semiconductor devices, discharges can cause abnormal operation. In such cases, use anti-static measures or processing to prevent discharges.

(3) Corrosive Gases, Dust, or Oil

Exposure to corrosive gases or contact with dust or oil may lead to chemical reactions that will adversely affect the device. If you use devices in such conditions, consider ways to prevent such exposure or to protect the devices.

(4) Radiation, Including Cosmic Radiation

Most devices are not designed for environments involving exposure to radiation or cosmic radiation. Users should provide shielding as appropriate.

(5) Smoke, Flame

CAUTION: Plastic molded devices are flammable, and therefore should not be used near combustible substances. If devices begin to smoke or burn, there is danger of the release of toxic gases. Customers considering the use of FUJITSU SEMICONDUCTOR products in other special environmental conditions should consult with sales representatives.

Please check the latest handling precautions at the following URL.
<http://edevice.fujitsu.com/fj/handling-e.pdf>

■ HANDLING DEVICES

• Power supply pins

In products with multiple VCC and VSS pins, respective pins at the same potential are interconnected within the device in order to prevent malfunctions such as latch-up. However, all of these pins should be connected externally to the power supply or ground lines in order to reduce electromagnetic emission levels, to prevent abnormal operation of strobe signals caused by the rise in the ground level, and to conform to the total output current rating.

Moreover, connect the current supply source with each Power supply pin and GND pin of this device at low impedance. It is also advisable that a ceramic capacitor of approximately 0.1 μF be connected as a bypass capacitor between each Power supply pin and GND pin near this device.

• Crystal oscillator circuit

Noise near the X0/X1 and X0A/X1A pins may cause the device to malfunction. Design the printed circuit board so that X0/X1, X0A/X1A pins, the crystal oscillator, and the bypass capacitor to ground are located as close to the device as possible.

It is strongly recommended that the PC board artwork be designed such that the X0/X1 and X0A/X1A pins are surrounded by ground plane as this is expected to produce stable operation.

• Using an external clock

When using an external clock, the clock signal should be driven to the X0,X0A pin only and the X1,X1A pin should be kept open.

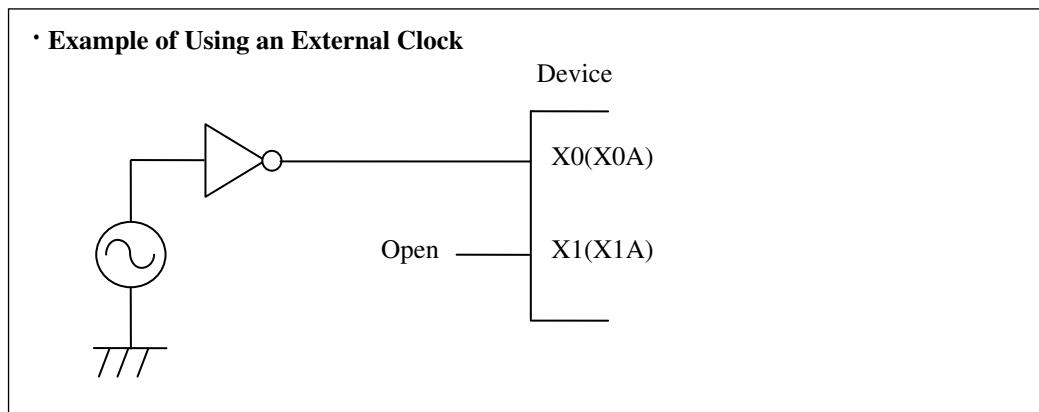

• Handling when using Multi function serial pin as I²C pin

If it is using the multi function serial pin as I²C pins, P-ch transistor of digital output is always disabled. However, I²C pins need to keep the electrical characteristic like other pins and not to connect to the external I²C bus system with power OFF.

MB9A310A Series

- C Pin

As this series includes a built-in regulator, always connect a bypass capacitor of approximately 4.7 μ F to the C pin for use by the regulator.

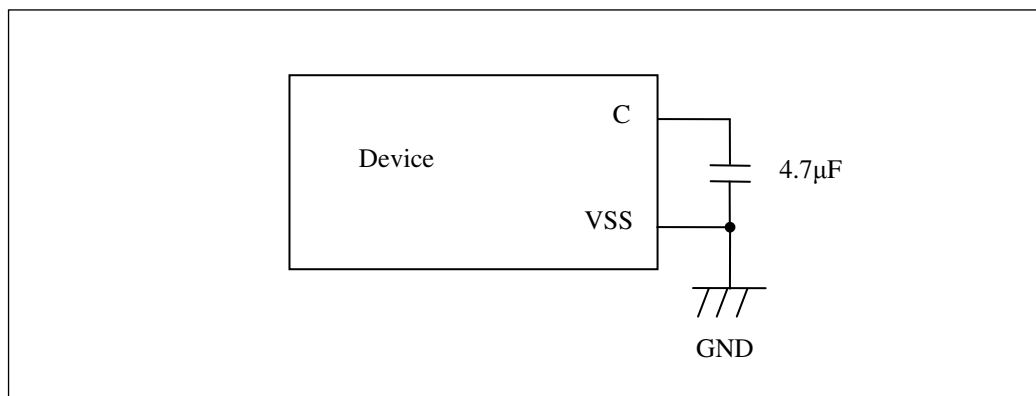

- Mode pins (MD0)

Connect the MD pin (MD0) directly to VCC or VSS pins. Design the printed circuit board such that the pull-up/down resistor stays low, as well as the distance between the mode pins and VCC pins or VSS pins is as short as possible and the connection impedance is low, when the pins are pulled-up/down such as for switching the pin level and rewriting the Flash memory data. It is because of preventing the device erroneously switching to test mode due to noise.

- Notes on power-on

Turn power on/off in the following order or at the same time.

If not using the A/D converter, connect AVCC = VCC and AVSS = VSS.

Turning on : VCC \rightarrow USBVCC

VCC \rightarrow AVCC \rightarrow AVRH

Turning off : USBVCC \rightarrow VCC

AVRH \rightarrow AVCC \rightarrow VCC

- Serial Communication

There is a possibility to receive wrong data due to the noise or other causes on the serial communication. Therefore, design a printed circuit board so as to avoid noise.

Consider the case of receiving wrong data due to noise, perform error detection such as by applying a checksum of data at the end. If an error is detected, retransmit the data.

- Differences in features among the products with different memory sizes and between Flash products and MASK products

The electric characteristics including power consumption, ESD, latch-up, noise characteristics, and oscillation characteristics among the products with different memory sizes and between Flash products and MASK products are different because chip layout and memory structures are different.

If you are switching to use a different product of the same series, please make sure to evaluate the electric characteristics.

■ BLOCK DIAGRAM

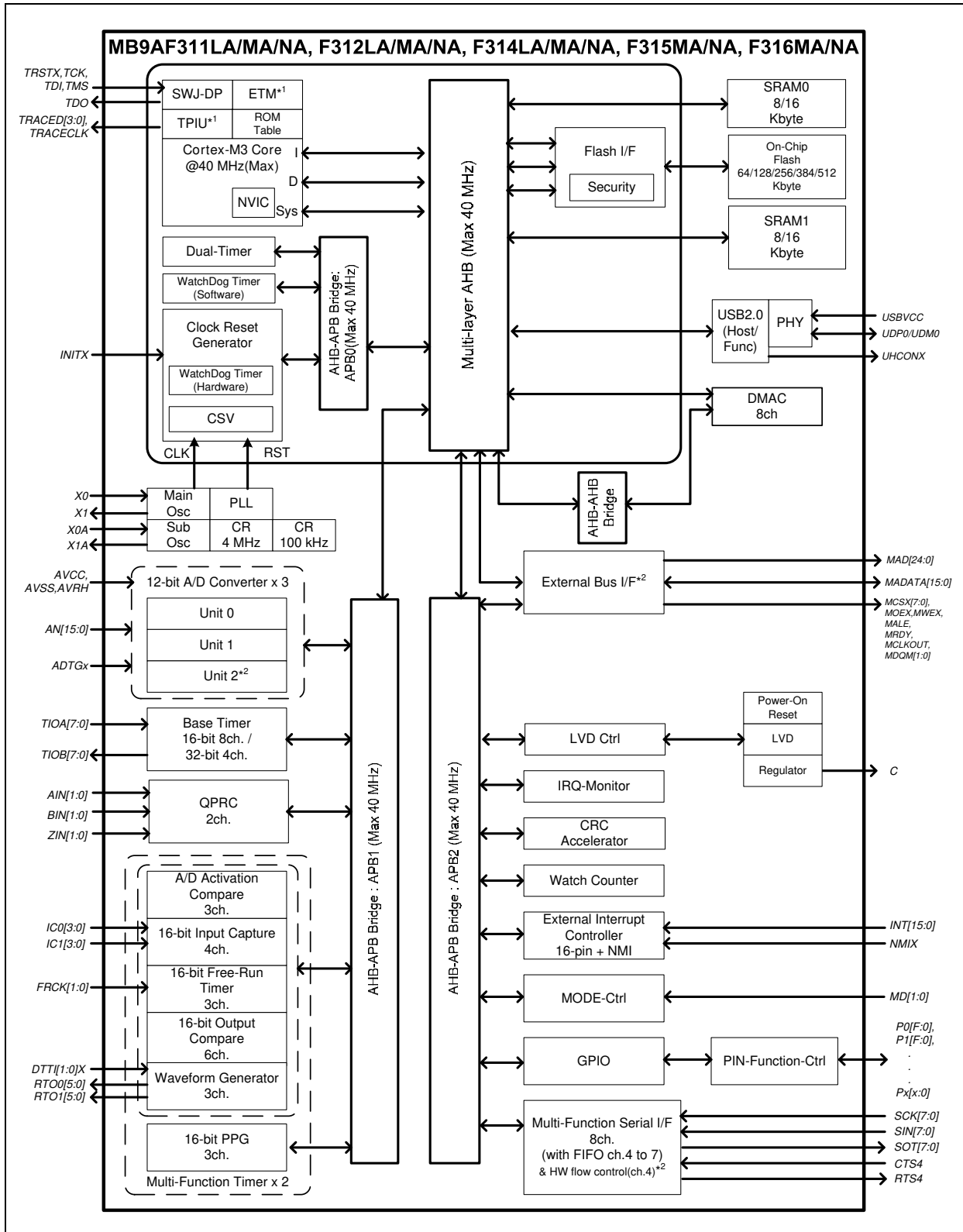

*1: For the MB9AF311LA/MA, F312LA/MA, MB9AF314LA/MA, MB9AF315MA and MB9AF316MA, ETM is not available.

*2: For the MB9AF311LA, F312LA and MB9AF314LA, the External Bus Interface and 12-bit A/D Converter (unit 2) are not available. And the Multi-function Serial Interface does not support hardware flow control in these products.

■ MEMORY SIZE

See "●Memory size" in "■PRODUCT LINEUP" to confirm the memory size.

■ MEMORY MAP

· MB9A310A Series Memory Map(1)

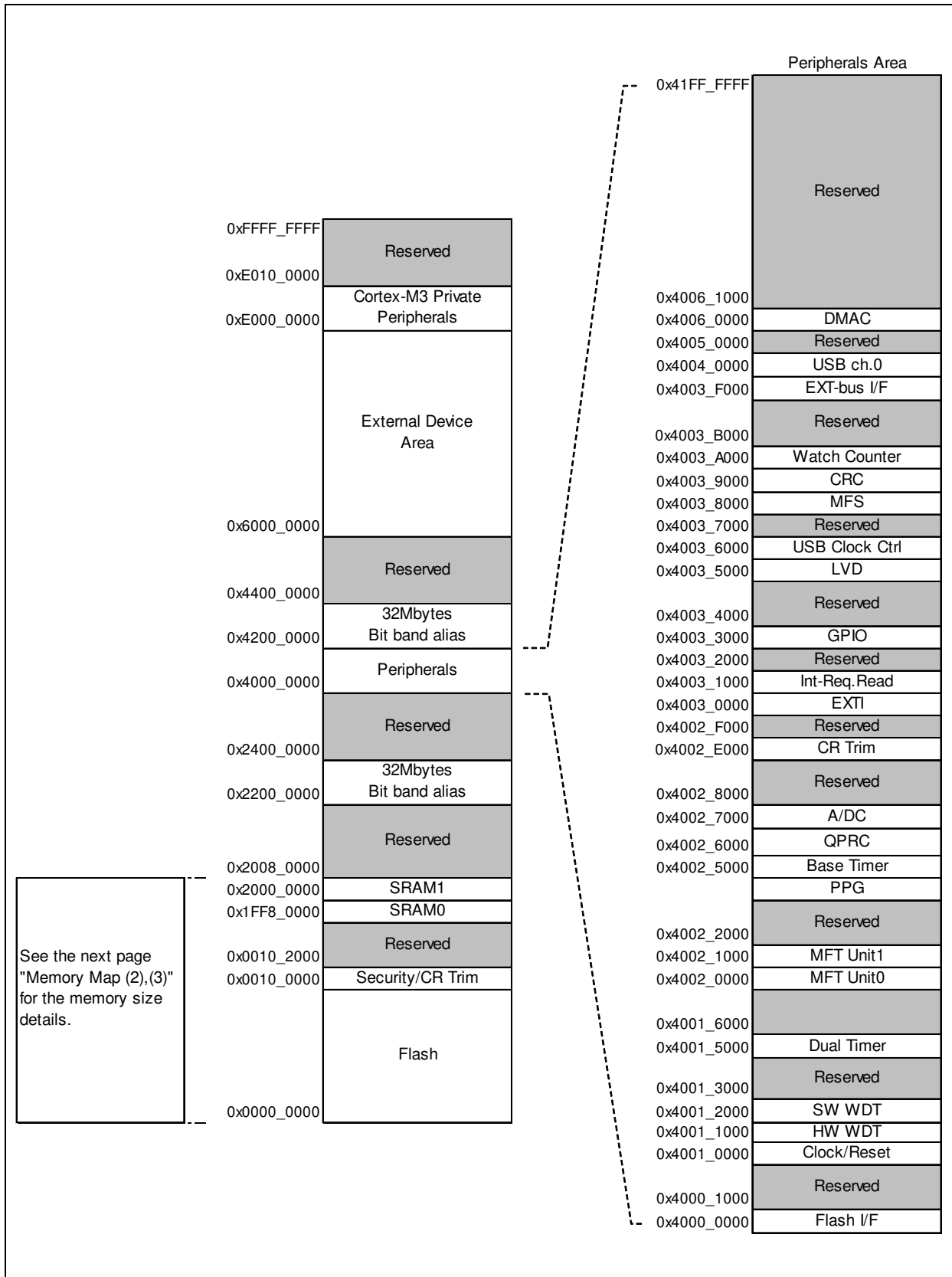

See the next page "Memory Map (2),(3)" for the memory size details.

MB9A310A Series

· MB9A310A Series Memory Map(2)

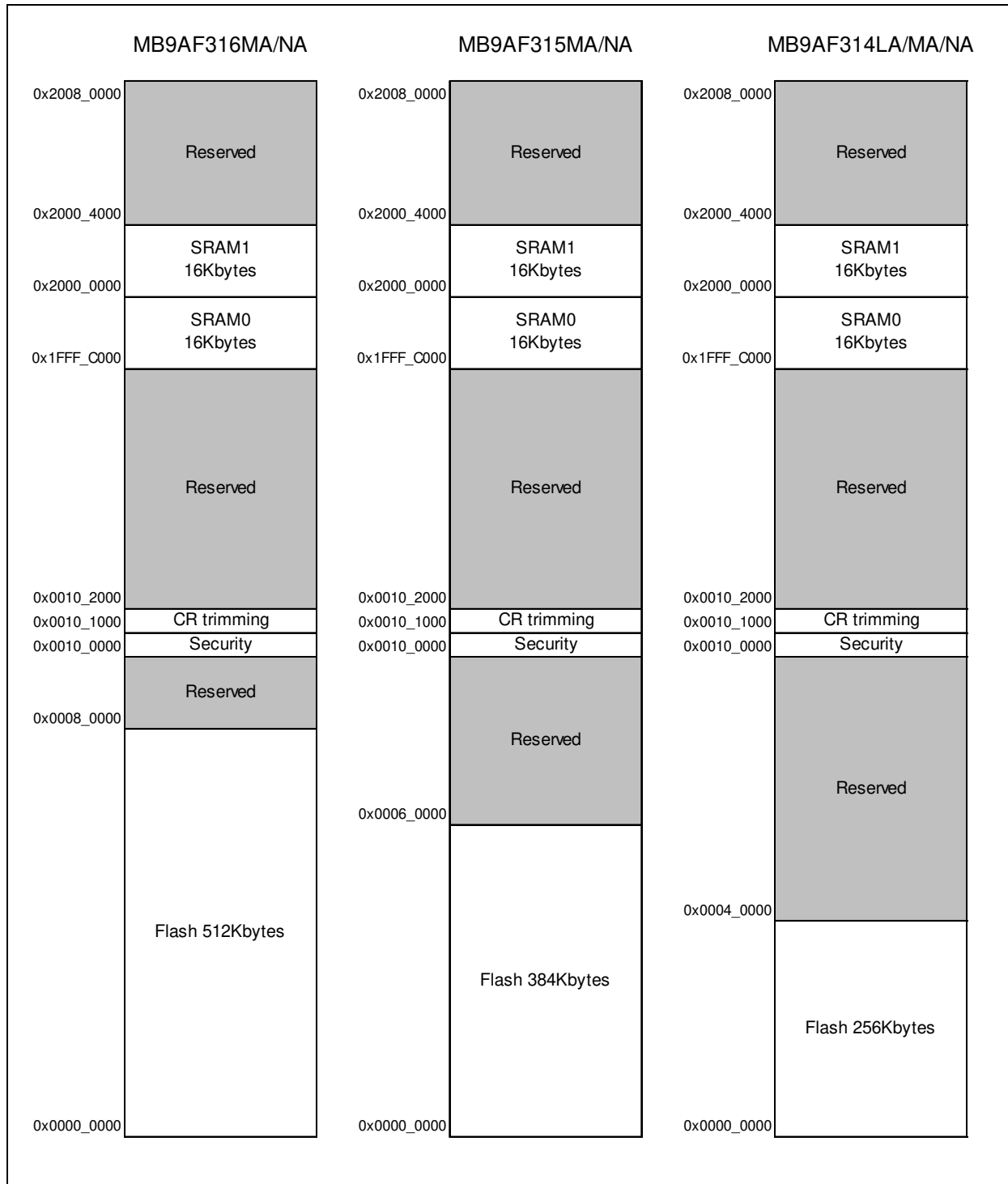

• MB9A310A Series Memory Map(3)

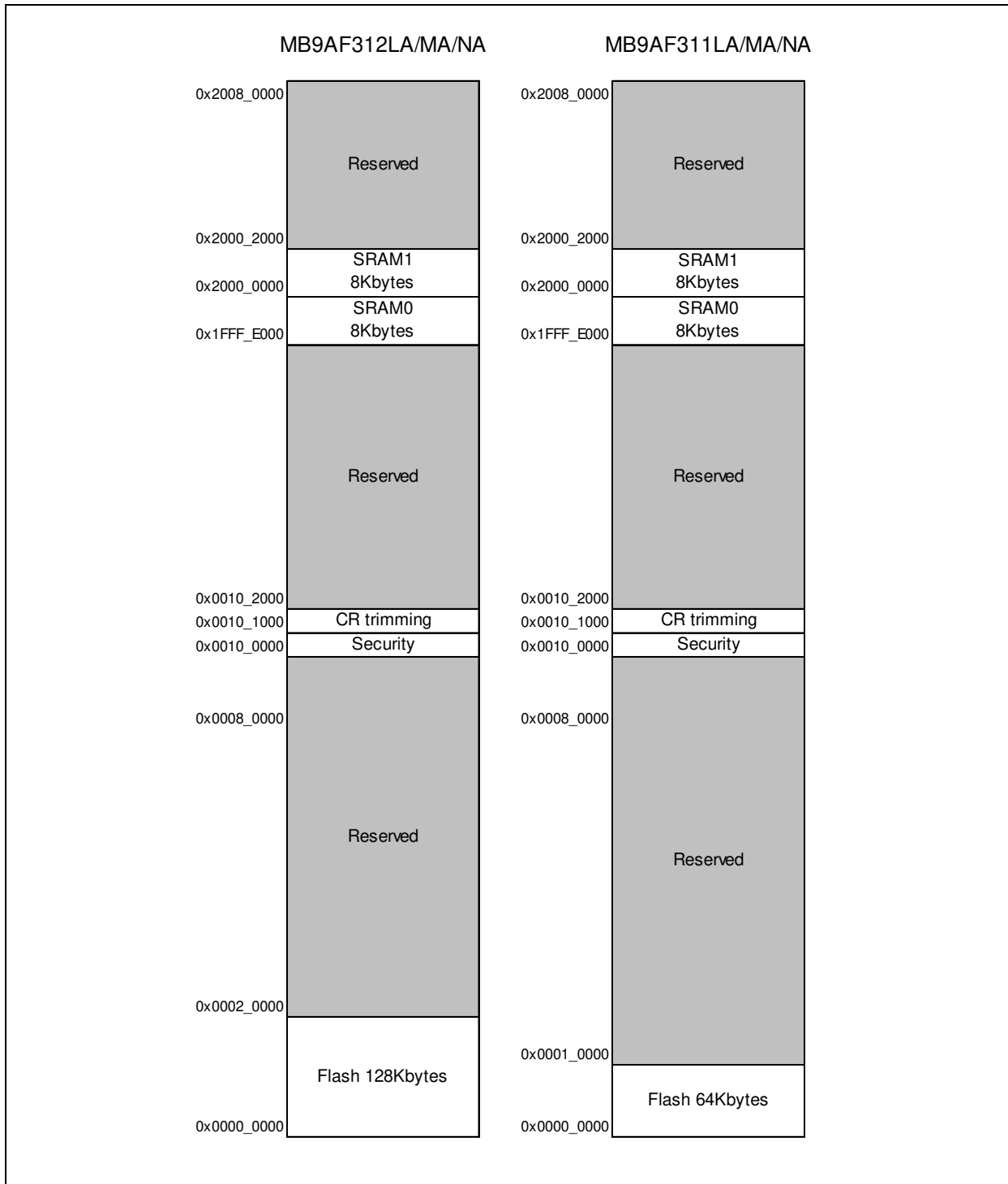

MB9A310A Series

· Peripheral Address Map

Start address	End address	Bus	Peripherals
0x4000_0000 _H	0x4000_0FFF _H	AHB	Flash I/F register
0x4000_1000 _H	0x4000_FFFF _H		Reserved
0x4001_0000 _H	0x4001_0FFF _H	APB0	Clock/Reset Control
0x4001_1000 _H	0x4001_1FFF _H		Hardware Watchdog timer
0x4001_2000 _H	0x4001_2FFF _H		Software Watchdog timer
0x4001_3000 _H	0x4001_4FFF _H		Reserved
0x4001_5000 _H	0x4001_5FFF _H		Dual-Timer
0x4001_6000 _H	0x4001_FFFF _H		Reserved
0x4002_0000 _H	0x4002_0FFF _H	APB1	Multi-function timer unit0
0x4002_1000 _H	0x4002_1FFF _H		Multi-function timer unit1
0x4002_2000 _H	0x4002_3FFF _H		Reserved
0x4002_4000 _H	0x4002_4FFF _H		PPG
0x4002_5000 _H	0x4002_5FFF _H		Base Timer
0x4002_6000 _H	0x4002_6FFF _H		Quadrature Position/Revolution Counter
0x4002_7000 _H	0x4002_7FFF _H		A/D Converter
0x4002_8000 _H	0x4002_DFFF _H		Reserved
0x4002_E000 _H	0x4002_EFFF _H		Built-in CR trimming
0x4002_F000 _H	0x4002_FFFF _H		Reserved
0x4003_0000 _H	0x4003_0FFF _H	APB2	External Interrupt Controller
0x4003_1000 _H	0x4003_1FFF _H		Interrupt Source Check Register
0x4003_2000 _H	0x4003_2FFF _H		Reserved
0x4003_3000 _H	0x4003_3FFF _H		GPIO
0x4003_4000 _H	0x4003_4FFF _H		Reserved
0x4003_5000 _H	0x4003_5FFF _H		Low-Voltage Detector
0x4003_6000 _H	0x4003_6FFF _H		USB clock generator
0x4003_7000 _H	0x4003_7FFF _H		Reserved
0x4003_8000 _H	0x4003_8FFF _H		Multi-function serial
0x4003_9000 _H	0x4003_9FFF _H		CRC
0x4003_A000 _H	0x4003_AFFF _H		Watch Counter
0x4003_B000 _H	0x4003_EFFF _H		Reserved
0x4003_F000 _H	0x4003_FFFF _H		External bus interface
0x4004_0000 _H	0x4004_FFFF _H	AHB	USB ch.0
0x4005_0000 _H	0x4005_FFFF _H		Reserved
0x4006_0000 _H	0x4006_0FFF _H		DMAC register
0x4006_1000 _H	0x4006_1FFF _H		Reserved
0x4006_2000 _H	0x4006_2FFF _H		Reserved
0x4006_3000 _H	0x4006_3FFF _H		Reserved
0x4006_4000 _H	0x41FF_FFFF _H		Reserved

■ PIN STATUS IN EACH CPU STATE

The terms used for pin status have the following meanings.

- INITX = 0
This is the period when the INITX pin is the "L" level.
- INITX = 1
This is the period when the INITX pin is the "H" level.
- SPL = 0
This is the status that the standby pin level setting bit (SPL) in the standby mode control register (STB_CTL) is set to "0".
- SPL = 1
This is the status that the standby pin level setting bit (SPL) in the standby mode control register (STB_CTL) is set to "1".
- Input enabled
Indicates that the input function can be used.
- Internal input fixed at "0"
This is the status that the input function cannot be used. Internal input is fixed at "L".
- Hi-Z
Indicates that the pin drive transistor is disabled and the pin is put in the Hi-Z state.
- Setting disabled
Indicates that the setting is disabled.
- Maintain previous state
Maintains the state that was immediately prior to entering the current mode.
If a built-in peripheral function is operating, the output follows the peripheral function.
If the pin is being used as a port, that output is maintained.
- Analog input is enabled
Indicates that the analog input is enabled.
- Trace output
Indicates that the trace function can be used.

MB9A310A Series

· LIST OF PIN STATUS

Pin status type	Function group	Power-on reset or low voltage detection state	INITX input state	Device internal reset state	Run mode or sleep mode state	Timer mode or STOP mode state	
		Power supply unstable	Power supply stable		Power supply stable	Power supply stable	
		-	INITX=0	INITX=1	INITX=1	INITX=1	
		-	-	-	-	SPL=0	SPL=1
A	GPIO selected	Setting disabled	Setting disabled	Setting disabled	Maintain previous state	Maintain previous state	Hi-Z/ Internal input fixed at "0"
	Main crystal oscillator input pin	Input enabled	Input enabled	Input enabled	Input enabled	Input enabled	Input enabled
B	GPIO selected	Setting disabled	Setting disabled	Setting disabled	Maintain previous state	Maintain previous state	Hi-Z/ Internal input fixed at "0"
	Main crystal oscillator output pin	Hi-Z/ Internal input fixed at "0"/ or Input enabled	Hi-Z/ Internal input fixed at "0"	Hi-Z/ Internal input fixed at "0"	Maintain previous state	Maintain previous state/ Hi-Z at oscillation stop*1/ Internal input fixed at "0"	Maintain previous state/ Hi-Z at oscillation stop*1/ Internal input fixed at "0"
C	INITX input pin	Pull-up/ Input enabled	Pull-up/ Input enabled	Pull-up/ Input enabled	Pull-up/ Input enabled	Pull-up/ Input enabled	Pull-up/ Input enabled
D	Mode input pin	Input enabled	Input enabled	Input enabled	Input enabled	Input enabled	Input enabled
E	JTAG selected	Hi-Z	Pull-up/ Input enabled	Pull-up/ Input enabled	Maintain previous state	Maintain previous state	Maintain previous state
	GPIO selected	Setting disabled	Setting disabled	Setting disabled			Hi-Z/ Internal input fixed at "0"
F	Trace selected	Setting disabled	Setting disabled	Setting disabled	Maintain previous state	Maintain previous state	Trace output
	External interrupt enabled selected						Maintain previous state
	GPIO selected, or resource other than above selected	Hi-Z	Hi-Z/ Input enabled	Hi-Z/ Input enabled			Hi-Z/ Internal input fixed at "0"

Pin status type	Function group	Power-on reset or low voltage detection state	INITX input state	Device internal reset state	Run mode or sleep mode state	Timer mode or STOP mode state	
		Power supply unstable	Power supply stable		Power supply stable	Power supply stable	
		-	INITX=0	INITX=1	INITX=1	INITX=1	
		-	-	-	-	SPL=0	SPL=1
G	Trace selected	Setting disabled	Setting disabled	Setting disabled	Maintain previous state	Maintain previous state	Trace output
	GPIO selected, or resource other than above selected	Hi-Z	Hi-Z/ Input enabled	Hi-Z/ Input enabled			Hi-Z/ Internal input fixed at "0"
H	External interrupt enabled selected	Setting disabled	Setting disabled	Setting disabled	Maintain previous state	Maintain previous state	Maintain previous state
	GPIO selected, or resource other than above selected	Hi-Z	Hi-Z/ Input enabled	Hi-Z/ Input enabled			Hi-Z/ Internal input fixed at "0"
I	GPIO selected, resource selected	Hi-Z	Hi-Z/ Input enabled	Hi-Z/ Input enabled	Maintain previous state	Maintain previous state	Hi-Z/ Internal input fixed at "0"
J	NMIX selected	Setting disabled	Setting disabled	Setting disabled	Maintain previous state	Maintain previous state	Maintain previous state
	GPIO selected, or resource other than above selected	Hi-Z	Hi-Z/ Input enabled	Hi-Z/ Input enabled			Hi-Z/ Internal input fixed at "0"

MB9A310A Series

Pin status type	Function group	Power-on reset or low voltage detection state	INITX input state	Device internal reset state	Run mode or sleep mode state	Timer mode or STOP mode state	
		Power supply unstable	Power supply stable		Power supply stable	Power supply stable	
		-	INITX=0	INITX=1	INITX=1	INITX=1	
		-	-	-	-	SPL=0	SPL=1
K	Analog input selected	Hi-Z	Hi-Z/ Internal input fixed at "0"/ Analog input enabled	Hi-Z/ Internal input fixed at "0"/ Analog input enabled	Hi-Z/ Internal input fixed at "0"/ Analog input enabled	Hi-Z/ Internal input fixed at "0"/ Analog input enabled	Hi-Z/ Internal input fixed at "0"/ Analog input enabled
	GPIO selected, or resource other than above selected	Setting disabled	Setting disabled	Setting disabled	Maintain previous state	Maintain previous state	Hi-Z/ Internal input fixed at "0"
L	External interrupt enabled selected	Setting disabled	Setting disabled	Setting disabled	Maintain previous state	Maintain previous state	Maintain previous state
	Analog input selected	Hi-Z	Hi-Z/ Internal input fixed at "0"/ Analog input enabled	Hi-Z/ Internal input fixed at "0"/ Analog input enabled	Hi-Z/ Internal input fixed at "0"/ Analog input enabled	Hi-Z/ Internal input fixed at "0"/ Analog input enabled	Hi-Z/ Internal input fixed at "0"/ Analog input enabled
	GPIO selected, or resource other than above selected	Setting disabled	Setting disabled	Setting disabled	Maintain previous state	Maintain previous state	Hi-Z/ Internal input fixed at "0"
M	GPIO selected	Setting disabled	Setting disabled	Setting disabled	Maintain previous state	Maintain previous state	Hi-Z/ Internal input fixed at "0"
	Sub crystal oscillator input pin	Input enabled	Input enabled	Input enabled	Input enabled	Input enabled	Input enabled

Pin status type	Function group	Power-on reset or low voltage detection state	INITX input state	Device internal reset state	Run mode or sleep mode state	Timer mode or STOP mode state	
		Power supply unstable	Power supply stable		Power supply stable	Power supply stable	
		-	INITX=0	INITX=1	INITX=1	INITX=1	
		-	-	-	-	SPL=0	SPL=1
N	GPIO selected	Setting disabled	Setting disabled	Setting disabled	Maintain previous state	Maintain previous state	Hi-Z/ Internal input fixed at "0"
	Sub crystal oscillator output pin	Hi-Z/ Internal input fixed at "0"/ or Input enabled	Hi-Z/ Internal input fixed at "0"	Hi-Z/ Internal input fixed at "0"	Maintain previous state	Maintain previous state/ Hi-Z at oscillation stop*2/ Internal input fixed at "0"	Maintain previous state/ Hi-Z at oscillation stop*2/ Internal input fixed at "0"
O	GPIO selected	Hi-Z	Hi-Z/ Input enabled	Hi-Z/ Input enabled	Maintain previous state	Maintain previous state	Hi-Z/ Internal input fixed at "0"
	USB I/O pin	Setting disabled	Setting disabled	Setting disabled	Maintain previous state	Hi-Z at transmission / Input enabled/ Internal input fixed at "0" at reception	Hi-Z at transmission / Input enabled/ Internal input fixed at "0" at reception
P	Mode input pin	Input enabled	Input enabled	Input enabled	Input enabled	Input enabled	Input enabled
	GPIO selected	Setting disabled	Setting disabled	Setting disabled	Maintain previous state	Maintain previous state	Hi-Z/Input enabled

*1 : Oscillation is stopped at sub timer mode, low speed CR timer mode, and stop mode.

*2 : Oscillation is stopped at stop mode.

MB9A310A Series

■ ELECTRICAL CHARACTERISTICS

1. Absolute Maximum Ratings

Parameter	Symbol	Rating		Unit	Remarks
		Min	Max		
Power supply voltage* ¹ , * ²	V _{CC}	V _{SS} - 0.5	V _{SS} + 6.5	V	
Power supply voltage (for USB) * ¹ , * ³	USBV _{CC}	V _{SS} - 0.5	V _{SS} + 6.5	V	
Analog power supply voltage* ¹ , * ⁴	AV _{CC}	V _{SS} - 0.5	V _{SS} + 6.5	V	
Analog reference voltage* ¹ , * ⁴	AV _{RH}	V _{SS} - 0.5	V _{SS} + 6.5	V	
Input voltage* ¹	V _I	V _{SS} - 0.5	V _{CC} + 0.5 (≤ 6.5V)	V	Except for USB pin
		V _{SS} - 0.5	USBV _{CC} + 0.5 (≤ 6.5V)	V	USB pin
		V _{SS} - 0.5	V _{SS} + 6.5	V	5V tolerant
Analog pin input voltage* ¹	V _{IA}	V _{SS} - 0.5	AV _{CC} + 0.5 (≤ 6.5V)	V	
Output voltage* ¹	V _O	V _{SS} - 0.5	V _{CC} + 0.5 (≤ 6.5V)	V	
"L" level maximum output current* ⁵	I _{OL}	-	10	mA	4mA type
			20	mA	12mA type
"L" level average output current* ⁶	I _{OLAV}	-	4	mA	4mA type
			12	mA	12mA type
"L" level total maximum output current	∑I _{OL}	-	100	mA	
"L" level total average output current* ⁷	∑I _{OLAV}	-	50	mA	
"H" level maximum output current* ⁵	I _{OH}	-	- 10	mA	4mA type
			- 20	mA	12mA type
"H" level average output current* ⁶	I _{OHAV}	-	- 4	mA	4mA type
			- 12	mA	12mA type
"H" level total maximum output current	∑I _{OH}	-	- 100	mA	
"H" level total average output current* ⁷	∑I _{OHAV}	-	- 50	mA	
Power consumption	P _D	-	300	mW	
Storage temperature	T _{STG}	- 55	+ 150	°C	

*1 : These parameters are based on the condition that V_{SS} = AV_{SS} = 0.0V.

*2 : V_{CC} must not drop below V_{SS} - 0.5V.

*3 : USBV_{CC} must not drop below V_{SS} - 0.5V.

*4 : Be careful not to exceed V_{CC} + 0.5 V, for example, when the power is turned on.

*5 : The maximum output current is defined as the value of the peak current flowing through any one of the corresponding pins.

*6 : The average output current is defined as the average current value flowing through any one of the corresponding pins for a 100 ms period.

*7 : The total average output current is defined as the average current value flowing through all of corresponding pins for a 100ms.

<WARNING>

Semiconductor devices can be permanently damaged by application of stress (voltage, current, temperature, etc.) in excess of absolute maximum ratings. Do not exceed these ratings.

2. Recommended Operating Conditions

(V_{SS} = AV_{SS} = 0.0V)

Parameter	Symbol	Conditions	Value		Unit	Remarks	
			Min	Max			
Power supply voltage	V _{CC}	-	2.7	5.5	V		
Power supply voltage (3V power supply) for USB	USBV _{CC}		3.0	3.6 (≤ V _{CC})	V	*1	
			2.7	5.5 (≤ V _{CC})		*2	
Analog power supply voltage	AV _{CC}	-	2.7	5.5	V	AV _{CC} = V _{CC}	
Analog reference voltage	AV _{RH}	-	AV _{SS}	AV _{CC}	V		
Operating temperature	FPT-100P-M20 FPT-100P-M23 FPT-80P-M21 FPT-80P-M37 FPT-64P-M24 FPT-64P-M38 FPT-64P-M23 FPT-64P-M39 LCC-64P-M24 BGA-112P-M04	T _a	-	- 40	+ 105	°C	
	FPT-100P-M06	T _a	When mounted on four-layer PCB	- 40	+ 105	°C	
			When mounted on double-sided single-layer PCB	- 40	+ 105	°C	I _{CC} ≤ 35mA
				- 40	+ 85	°C	I _{CC} > 35mA

*1: When P81/UDP0 and P80/UDM0 pin are used as USB (UDP0, UDM0).

*2: When P81/UDP0 and P80/UDM0 pin are used as GPIO (P81, P80).

<WARNING>

The recommended operating conditions are required in order to ensure the normal operation of the semiconductor device. All of the device's electrical characteristics are warranted when the device is operated within these ranges.

Always use semiconductor devices within their recommended operating condition ranges. Operation outside these ranges may adversely affect reliability and could result in device failure. No warranty is made with respect to uses, operating conditions, or combinations not represented on the data sheet. Users considering application outside the listed conditions are advised to contact their representatives beforehand.

MB9A310A Series

3. DC Characteristics

· Current rating

(Vcc = AVcc = 2.7V to 5.5V, USBVcc = 3.0V to 3.6V, Vss = AVss = 0V, Ta = - 40°C to + 105°C)

Parameter	Symbol	Pin name	Conditions	Value			Unit	Remarks
				Min	Typ	Max		
Power supply current	Icc	Vcc	Normal operation (PLL) Vcc = 5.5V	-	32	41	mA	CPU : 40MHz, Peripheral : 40MHz, Flash 0Wait FRWTR.RWT = 00 FSYNDN.SD = 000 *1
				-	21	28	mA	CPU : 40MHz, Peripheral : 40MHz, Flash 3Wait FRWTR.RWT = 00 FSYNDN.SD = 011 *1
			Normal operation (built-in high-speed CR) Vcc = 5.5V	-	3.9	7.7	mA	CPU/ Peripheral : 4MHz *1, *2 Flash 0Wait FRWTR.RWT = 00 FSYNDN.SD = 000
			Normal operation (sub oscillation) Vcc = 5.5V	-	0.15	3.2	mA	CPU/ Peripheral : 32kHz Flash 0Wait FRWTR.RWT = 00 FSYNDN.SD = 000 *1
			Normal operation (built-in low-speed CR) Vcc = 5.5V	-	0.2	3.3	mA	CPU/ Peripheral : 100kHz Flash 0Wait FRWTR.RWT = 00 FSYNDN.SD = 000 *1
			SLEEP operation (PLL) Vcc = 5.5V	-	10	15	mA	Peripheral : 40MHz *1
	Iccs	Vcc	SLEEP operation (built-in high-speed CR) Vcc = 5.5V	-	1.2	4.4	mA	Peripheral : 4MHz *1, *2
			SLEEP operation (sub oscillation) Vcc = 5.5V	-	0.1	3.1	mA	Peripheral : 32kHz *1
			SLEEP operation (built in low-speed CR) Vcc = 5.5V	-	0.1	3.1	mA	Peripheral : 100kHz *1

Parameter	Symbol	Pin name	Conditions	Value			Unit	Remarks
				Min	Typ	Max		
Power supply current	I _{CCH}	V _{CC}	STOP mode V _{CC} = 5.5V	-	35	200	μA	Ta = + 25°C, When LVD is off *1
				-	-	3	mA	Ta = + 105°C, When LVD is off *1
	I _{CCT}		TIMER mode (sub oscillation) V _{CC} = 5.5V	-	60	230	μA	Ta = + 25°C, When LVD is off *1
				-	-	3.1	mA	Ta = + 105°C, When LVD is off *1
Low-voltage detection circuit (LVD) power supply current	I _{CLVD}		At operation V _{CC} = 5.5V	-	4	7	μA	For occurrence of interrupt

*1: When all ports are fixed.

*2: When setting it to 4MHz by trimming.

MB9A310A Series

· Pin Characteristics

($V_{CC} = AV_{CC} = 2.7V$ to $5.5V$, $V_{SS} = AV_{SS} = 0V$, $T_a = -40^{\circ}C$ to $+105^{\circ}C$)

Parameter	Symbol	Pin name	Conditions	Value			Unit	Remarks
				Min	Typ	Max		
"H" level input voltage (hysteresis input)	V_{IHS}	CMOS hysteresis input pin, MD0,1	-	$V_{CC} \times 0.8$	-	$V_{CC} + 0.3$	V	
		5V tolerant I/O pin	-	$V_{CC} \times 0.8$	-	$V_{SS} + 5.5$	V	
"L" level input voltage (hysteresis input)	V_{ILS}	CMOS hysteresis input pin, MD0,1	-	$V_{SS} - 0.3$	-	$V_{CC} \times 0.2$	V	
"H" level output voltage	V_{OH}	4mA type	$V_{CC} \geq 4.5V$ $I_{OH} = -4mA$	$V_{CC} - 0.5$	-	V_{CC}	V	
			$V_{CC} < 4.5V$ $I_{OH} = -2mA$					
		12mA type	$V_{CC} \geq 4.5V$ $I_{OH} = -12mA$	$V_{CC} - 0.5$	-	V_{CC}	V	
			$V_{CC} < 4.5V$ $I_{OH} = -8mA$					
		The pin doubled as USB I/O	$V_{CC} \geq 4.5V$ $I_{OH} = -20.5mA$	$V_{CC} - 0.4$	-	V_{CC}	V	
			$V_{CC} < 4.5V$ $I_{OH} = -13.0mA$					
"L" level output voltage	V_{OL}	4mA type	$V_{CC} \geq 4.5V$ $I_{OL} = 4mA$	V_{SS}	-	0.4	V	
			$V_{CC} < 4.5V$ $I_{OL} = 2mA$					
		12mA type	$V_{CC} \geq 4.5V$ $I_{OL} = 12mA$	V_{SS}	-	0.4	V	
			$V_{CC} < 4.5V$ $I_{OL} = 8mA$					
		The pin doubled as USB I/O	$V_{CC} \geq 4.5V$ $I_{OL} = 18.5mA$	V_{SS}	-	0.4	V	
			$V_{CC} < 4.5V$ $I_{OL} = 10.5mA$					
Input leak current	I_{IL}	-	-	-5	-	+5	μA	
Pull-up resistor value	R_{PU}	Pull-up pin	$V_{CC} \geq 4.5V$	25	50	100	$k\Omega$	
			$V_{CC} < 4.5V$	30	80	200		
Input capacitance	C_{IN}	Other than V_{CC} , V_{SS} , AV_{CC} , AV_{SS} , AV_{RH}	-	-	5	15	pF	

4. AC Characteristics

(1) Main Clock Input Characteristics

($V_{CC} = 2.7V$ to $5.5V$, $V_{SS} = 0V$, $T_a = -40^{\circ}C$ to $+105^{\circ}C$)

Parameter	Symbol	Pin name	Conditions	Value		Unit	Remarks	
				Min	Max			
Input frequency	F_{CH}	X0 X1	$V_{CC} \geq 4.5V$	4	48	MHz	When crystal oscillator is connected	
			$V_{CC} < 4.5V$	4	20			
			$V_{CC} \geq 4.5V$	4	48	MHz	When using external clock	
			$V_{CC} < 4.5V$	4	20			
Input clock cycle	t_{CYLH}		$V_{CC} \geq 4.5V$	20.83	250	ns	When using external clock	
			$V_{CC} < 4.5V$	50	250			
Input clock pulse width	-			P_{WH}/t_{CYLH} P_{WL}/t_{CYLH}	45	55	%	When using external clock
Input clock rising time and falling time	t_{CF} t_{CR}			-	-	5	ns	When using external clock
Internal operating clock frequency	F_{CM}	-	-	-	40	MHz	Master clock	
	F_{CC}	-	-	-	40	MHz	Base clock (HCLK/FCLK)	
	F_{CP0}	-	-	-	40	MHz	APB0 bus clock (PCLK0)	
	F_{CP1}	-	-	-	40	MHz	APB1 bus clock (PCLK1)	
	F_{CP2}	-	-	-	40	MHz	APB2 bus clock (PCLK2)	
Internal operating clock cycle time	t_{CYCC}	-	-	25	-	ns	Base clock (HCLK/FCLK)	
	t_{CYCP0}	-	-	25	-	ns	APB0 bus clock (PCLK0)	
	t_{CYCP1}	-	-	25	-	ns	APB1 bus clock (PCLK1)	
	t_{CYCP2}	-	-	25	-	ns	APB2 bus clock (PCLK2)	

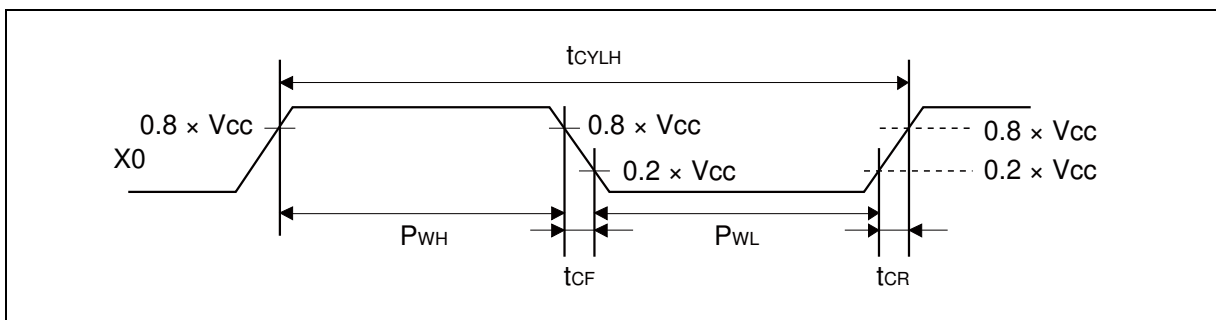

Note: For about each APB bus which each peripheral is connected to, see "■ BLOCK DIAGRAM" in this data sheet.

For more information about each internal operating clock, see "Chapter: Clock" in "FM3 Family PERIPHERAL MANUAL".

MB9A310A Series

(2) Sub Clock Input Characteristics

(V_{CC} = 2.7V to 5.5V, V_{SS} = 0V, Ta = - 40°C to + 105°C)

Parameter	Symbol	Pin name	Conditions	Value			Unit	Remarks
				Min	Typ	Max		
Input frequency	F _{CL}	X0A X1A	-	-	32.768	-	kHz	When crystal oscillator is connected
			-	32	-	100		kHz
Input clock cycle	t _{CYLL}		-	10	-	31.25	μs	When using external clock
Input clock pulse width	-		P _{WH} /t _{CYLL} P _{WL} /t _{CYLL}	45	-	55	%	When using external clock

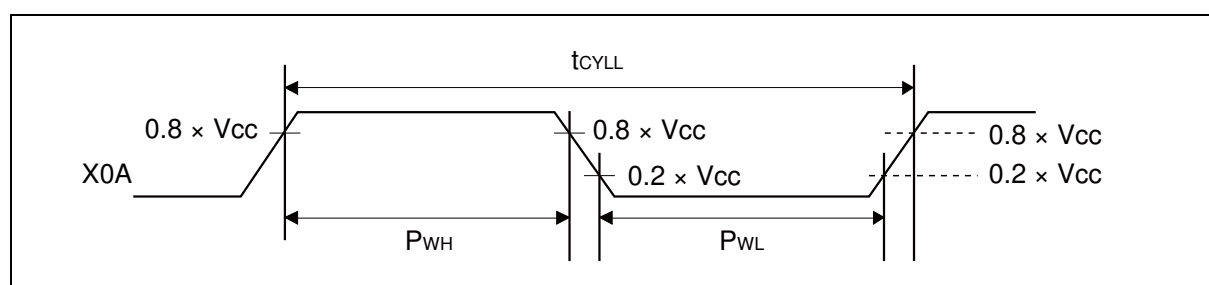

(3) Built-in CR Oscillation Characteristics

- Built-in high-speed CR

(V_{CC} = 2.7V to 5.5V, V_{SS} = 0V, Ta = - 40°C to + 105°C)

Parameter	Symbol	Conditions	Value			Unit	Remarks
			Min	Typ	Max		
Clock frequency	F _{CRH}	Ta = + 25°C	3.96	4	4.04	MHz	When trimming*
		Ta = 0°C to + 70°C	3.84	4	4.16		
		Ta = - 40°C to + 105°C	3.8	4	4.2		
		Ta = - 40°C to + 105°C	3	4	5		When not trimming

*: In the case of using the values in CR trimming area of Flash memory at shipment for frequency trimming.

- Built-in low-speed CR

(V_{CC} = 2.7V to 5.5V, V_{SS} = 0V, Ta = - 40°C to + 105°C)

Parameter	Symbol	Conditions	Value			Unit	Remarks
			Min	Typ	Max		
Clock frequency	F _{CRL}	-	50	100	150	kHz	

(4-1) Operating Conditions of Main and USB PLL (In the case of using main clock for input clock of PLL)

(V_{CC} = 2.7V to 5.5V, V_{SS} = 0V, T_a = - 40°C to + 105°C)

Parameter	Symbol	Value			Unit	Remarks
		Min	Typ	Max		
PLL oscillation stabilization wait time (LOCK UP time)*	t _{LOCK}	100	-	-	μs	
PLL input clock frequency	f _{PLLI}	4	-	16	MHz	
PLL multiple rate	-	13	-	75	multiple	
PLL macro oscillation clock frequency	f _{PLLO}	200	-	300	MHz	

*: Time from when the PLL starts operating until the oscillation stabilizes.

(4-2) Operating Conditions of Main PLL (In the case of using the built-in high speed CR for the input clock of the main PLL)

(V_{CC} = 2.7V to 5.5V, V_{SS} = 0V, T_a = - 40°C to + 105°C)

Parameter	Symbol	Value			Unit	Remarks
		Min	Typ	Max		
PLL oscillation stabilization wait time (LOCK UP time)*	t _{LOCK}	100	-	-	μs	
PLL input clock frequency	f _{PLLI}	3.8	4	4.2	MHz	
PLL multiple rate	-	50	-	71	multiple	
PLL macro oscillation clock frequency	f _{PLLO}	190	-	300	MHz	

*: Time from when the PLL starts operating until the oscillation stabilizes.

Note: Make sure to input the built-in high-speed CR clock that has been trimmed.

When setting PLL multiple rate, please take the accuracy of the built-in high-speed CR clock into account and prevent the master clock from exceeding the maximum frequency.

(5) Reset Input Characteristics

(V_{CC} = 2.7V to 5.5V, V_{SS} = 0V, T_a = - 40°C to + 105°C)

Parameter	Symbol	Pin name	Conditions	Value		Unit	Remarks
				Min	Max		
Reset input time	t _{INITX}	INITX	-	500	-	ns	

(6) Power-on Reset Timing

(V_{CC} = 2.7V to 5.5V, V_{SS} = 0V, T_a = - 40°C to + 105°C)

Parameter	Symbol	Pin name	Value		Unit	Remarks
			Min	Max		
Power supply rising time	Tr	V _{CC}	0	-	ms	
Power supply shut down time	Toff		1	-	ms	

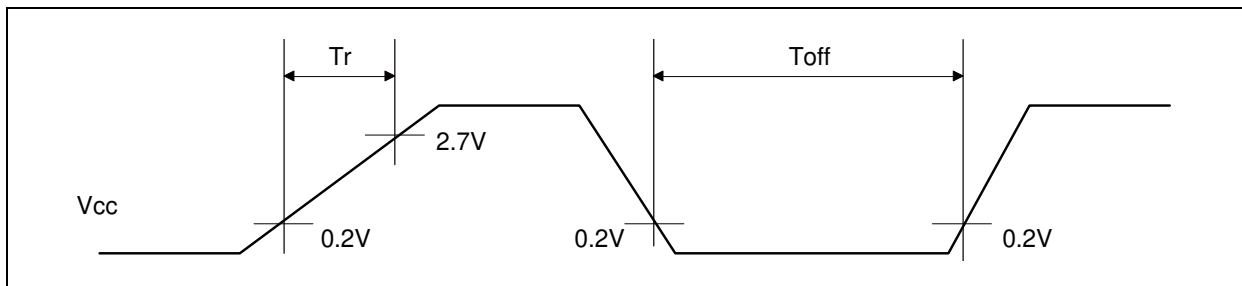

MB9A310A Series

(7) External Bus Timing

- External bus clock output Characteristics

($V_{CC} = 2.7V$ to $5.5V$, $V_{SS} = 0V$, $T_a = -40^{\circ}C$ to $+105^{\circ}C$)

Parameter	Symbol	Pin name	Conditions	Value		Unit
				Min	Max	
Output frequency	t_{CYCLE}	MCLKOUT	$V_{CC} \geq 4.5V$	-	40	MHz
			$V_{CC} < 4.5V$	-	32	MHz
Minimum clock cycle time	-		$V_{CC} \geq 4.5V$	25	-	ns
			$V_{CC} < 4.5V$	31.25	-	ns

Note: The external bus clock output is a divided clock of HCLK. For more information about setting of clock divider, see "Chapter: External Bus Interface" in "FM3 Family PERIPHERAL MANUAL"

When external bus clock is not output, this characteristics does not give any effect on external bus operation.

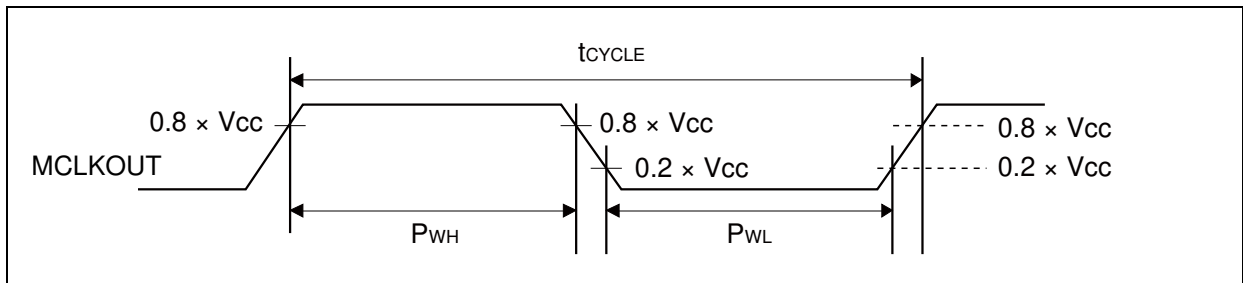

- External bus signal input/output Characteristics

($V_{CC} = 2.7V$ to $5.5V$, $V_{SS} = 0V$, $T_a = -40^{\circ}C$ to $+105^{\circ}C$)

Parameter	Symbol	Conditions	Value	Unit	Remarks
Signal input characteristics	V_{IH}	-	$0.8 \times V_{CC}$	V	
	V_{IL}		$0.2 \times V_{CC}$	V	
Signal output characteristics	V_{OH}		$0.8 \times V_{CC}$	V	
	V_{OL}		$0.2 \times V_{CC}$	V	

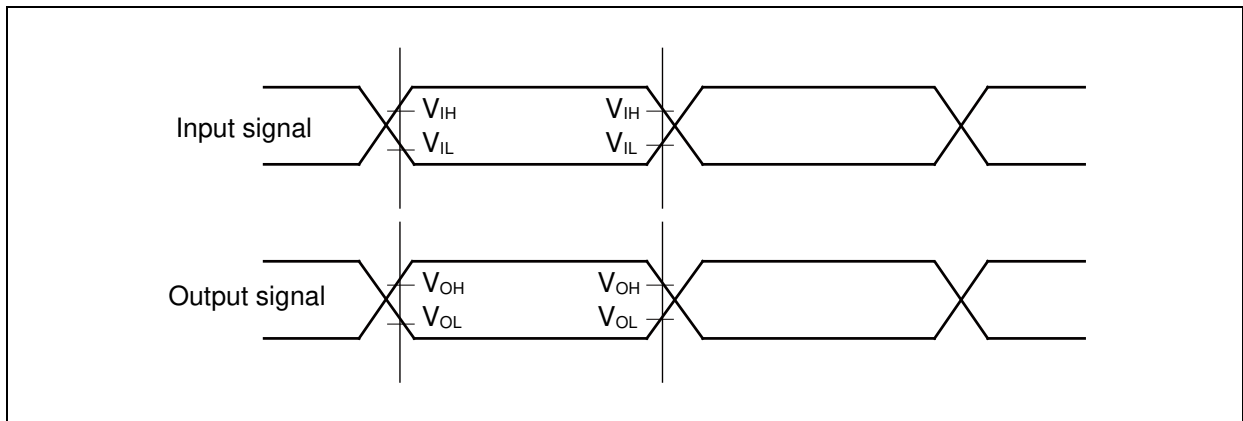

MB9A310A Series

- Separate Bus Access Asynchronous SRAM Mode

($V_{CC} = 2.7V$ to $5.5V$, $V_{SS} = 0V$, $T_a = -40^{\circ}C$ to $+105^{\circ}C$)

Parameter	Symbol	Pin name	Conditions	Value		Unit
				Min	Max	
MOEX Min pulse width	$t_{OE\bar{W}}$	MOEX	$V_{CC} \geq 4.5V$ $V_{CC} < 4.5V$	$MCLK \times n - 3$	-	ns
MCSX $\downarrow \rightarrow$ Address output delay time	$t_{CSL - AV}$	MCSX[7:0] MAD[24:0]	$V_{CC} \geq 4.5V$ $V_{CC} < 4.5V$	-9 -12	+9 +12	ns
MOEX $\uparrow \rightarrow$ Address hold time	$t_{OE\bar{H} - AX}$	MOEX MAD[24:0]	$V_{CC} \geq 4.5V$ $V_{CC} < 4.5V$	0	$MCLK \times m + 9$ $MCLK \times m + 12$	ns
MCSX $\downarrow \rightarrow$ MOEX \downarrow delay time	$t_{CSL - OEL}$	MOEX	$V_{CC} \geq 4.5V$ $V_{CC} < 4.5V$	$MCLK \times m - 9$ $MCLK \times m - 12$	$MCLK \times m + 9$ $MCLK \times m + 12$	ns
MOEX $\uparrow \rightarrow$ MCSX \uparrow time	$t_{OE\bar{H} - CSH}$	MCSX[7:0]	$V_{CC} \geq 4.5V$ $V_{CC} < 4.5V$	0	$MCLK \times m + 9$ $MCLK \times m + 12$	ns
MCSX $\downarrow \rightarrow$ MDQM \downarrow delay time	$t_{CSL - RDQML}$	MCSX MDQM[1:0]	$V_{CC} \geq 4.5V$ $V_{CC} < 4.5V$	$MCLK \times m - 9$ $MCLK \times m - 12$	$MCLK \times m + 9$ $MCLK \times m + 12$	ns
Data set up \rightarrow MOEX \uparrow time	$t_{DS - OE}$	MOEX MADATA[15:0]	$V_{CC} \geq 4.5V$ $V_{CC} < 4.5V$	20 38	- -	ns
MOEX $\uparrow \rightarrow$ Data hold time	$t_{DH - OE}$	MOEX MADATA[15:0]	$V_{CC} \geq 4.5V$ $V_{CC} < 4.5V$	0	-	ns
MWEX Min pulse width	$t_{WE\bar{W}}$	MWEX	$V_{CC} \geq 4.5V$ $V_{CC} < 4.5V$	$MCLK \times n - 3$	-	ns
MWEX $\uparrow \rightarrow$ Address output delay time	$t_{WE\bar{H} - AX}$	MWEX MAD[24:0]	$V_{CC} \geq 4.5V$ $V_{CC} < 4.5V$	0	$MCLK \times m + 9$ $MCLK \times m + 12$	ns
MCSX $\downarrow \rightarrow$ MWEX \downarrow delay time	$t_{CSL - WEL}$	MWEX	$V_{CC} \geq 4.5V$ $V_{CC} < 4.5V$	$MCLK \times n - 9$ $MCLK \times n - 12$	$MCLK \times n + 9$ $MCLK \times n + 12$	ns
MWEX $\uparrow \rightarrow$ MCSX \uparrow delay time	$t_{WE\bar{H} - CSH}$	MCSX[7:0]	$V_{CC} \geq 4.5V$ $V_{CC} < 4.5V$	0	$MCLK \times m + 9$ $MCLK \times m + 12$	ns
MCSX $\downarrow \rightarrow$ MDQM \downarrow delay time	$t_{CSL - WDQML}$	MCSX MDQM[1:0]	$V_{CC} \geq 4.5V$ $V_{CC} < 4.5V$	$MCLK \times n - 9$ $MCLK \times n - 12$	$MCLK \times n + 9$ $MCLK \times n + 12$	ns
MWEX $\downarrow \rightarrow$ Data output time	$t_{WEL - DV}$	MWEX	$V_{CC} \geq 4.5V$ $V_{CC} < 4.5V$	-9 -12	+9 +12	ns
MWEX $\uparrow \rightarrow$ Data hold time	$t_{WE\bar{H} - DX}$	MADATA[15:0]	$V_{CC} \geq 4.5V$ $V_{CC} < 4.5V$	0	$MCLK \times m + 9$ $MCLK \times m + 12$	ns

Note: When the external load capacitance $C_L = 30pF$ ($m = 0$ to 15 , $n = 1$ to 16).

MB9A310A Series

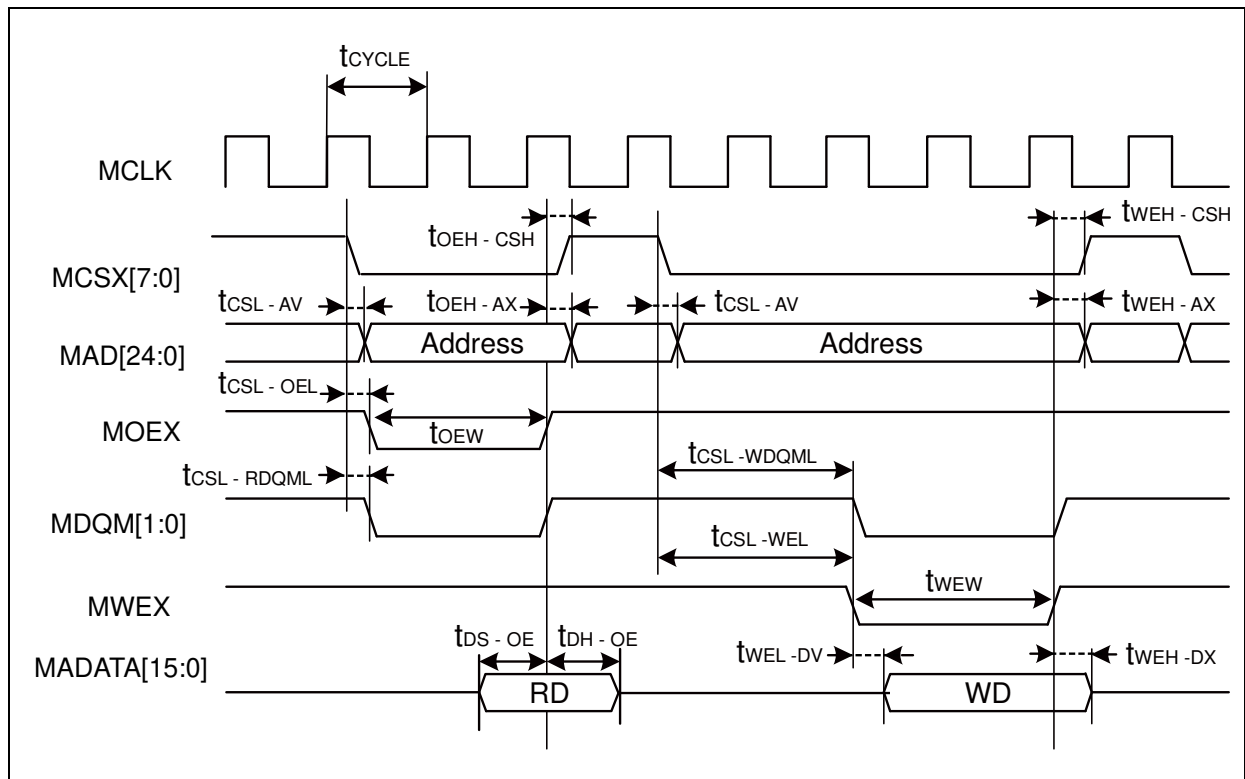

• Separate Bus Access Synchronous SRAM Mode

($V_{CC} = 2.7V$ to $5.5V$, $V_{SS} = 0V$, $T_a = -40^{\circ}C$ to $+105^{\circ}C$)

Parameter	Symbol	Pin name	Conditions	Value		Unit
				Min	Max	
Address delay time	t_{AV}	MCLK MAD[24:0]	$V_{CC} \geq 4.5V$	1	9	ns
			$V_{CC} < 4.5V$		12	
MCSX delay time	t_{CSL}	MCLK MCSX[7:0]	$V_{CC} \geq 4.5V$	1	9	ns
			$V_{CC} < 4.5V$		12	
	t_{CSH}		$V_{CC} \geq 4.5V$	1	9	ns
			$V_{CC} < 4.5V$		12	
MOEX delay time	t_{REL}	MCLK MOEX	$V_{CC} \geq 4.5V$	1	9	ns
			$V_{CC} < 4.5V$		12	
	t_{REH}		$V_{CC} \geq 4.5V$	1	9	ns
			$V_{CC} < 4.5V$		12	
Data set up → MCLK ↑ time	t_{DS}	MCLK MADATA[15:0]	$V_{CC} \geq 4.5V$	19	-	ns
			$V_{CC} < 4.5V$	37		
MCLK ↑ → Data hold time	t_{DH}	MCLK MADATA[15:0]	$V_{CC} \geq 4.5V$	0	-	ns
			$V_{CC} < 4.5V$			
MWEX delay time	t_{WEL}	MCLK MWEX	$V_{CC} \geq 4.5V$	1	9	ns
			$V_{CC} < 4.5V$		12	
	t_{WEH}		$V_{CC} \geq 4.5V$	1	9	ns
			$V_{CC} < 4.5V$		12	
MDQM[1:0] delay time	t_{DQML}	MCLK MDQM[1:0]	$V_{CC} \geq 4.5V$	1	9	ns
			$V_{CC} < 4.5V$		12	
	t_{DQMH}		$V_{CC} \geq 4.5V$	1	9	ns
			$V_{CC} < 4.5V$		12	
MCLK ↑ → Data output time	t_{OD}	MCLK MADATA[15:0]	$V_{CC} \geq 4.5V$	1	18	ns
			$V_{CC} < 4.5V$	1	24	

Note: When the external load capacitance $C_L = 30pF$.

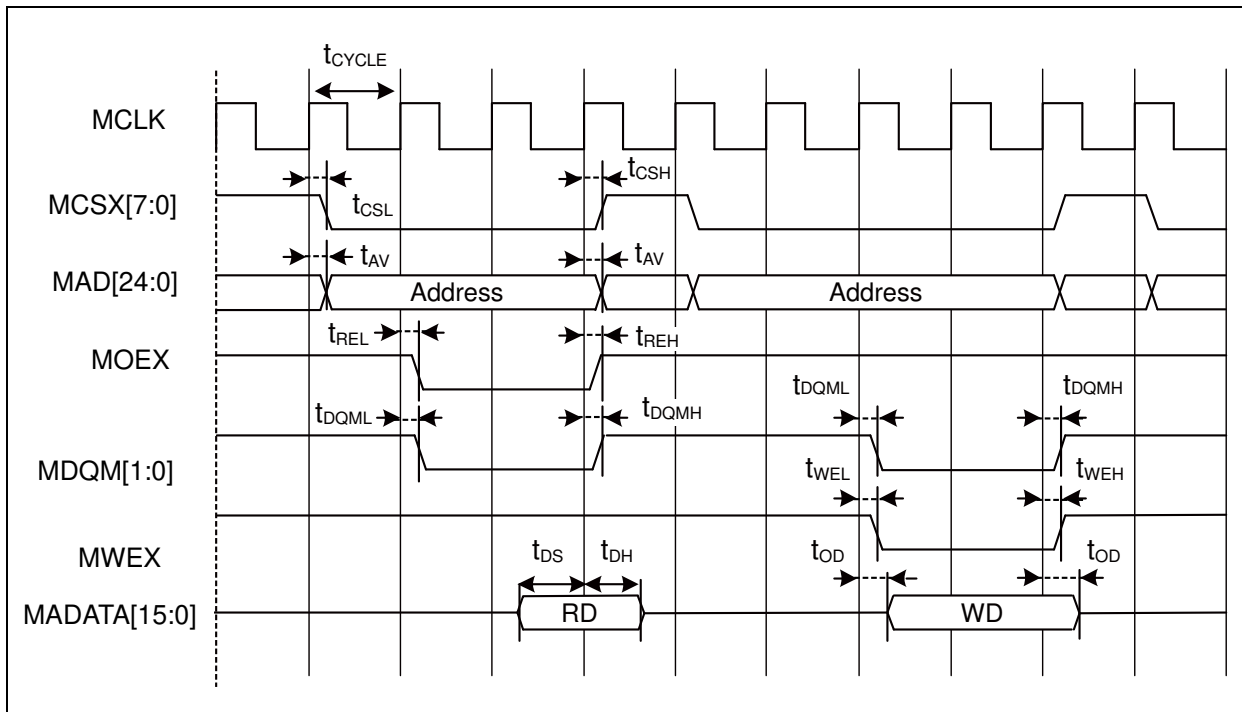

MB9A310A Series

• Multiplexed Bus Access Asynchronous SRAM Mode

($V_{CC} = 2.7V$ to $5.5V$, $V_{SS} = 0V$, $T_a = -40^{\circ}C$ to $+105^{\circ}C$)

Parameter	Symbol	Pin name	Conditions	Value		Unit
				Min	Max	
Multiplexed Address delay time	$t_{ALE-CHMADV}$	MALE MADATA[15:0]	$V_{CC} \geq 4.5V$	0	10	ns
			$V_{CC} < 4.5V$		20	
Multiplexed Address hold time	t_{CHMADH}	MALE MADATA[15:0]	$V_{CC} \geq 4.5V$	$MCLK \times n + 0$	$MCLK \times n + 10$	ns
			$V_{CC} < 4.5V$	$MCLK \times n + 0$	$MCLK \times n + 20$	

Note: When the external load capacitance $C_L = 30pF$ ($m = 0$ to 15 , $n = 1$ to 16).

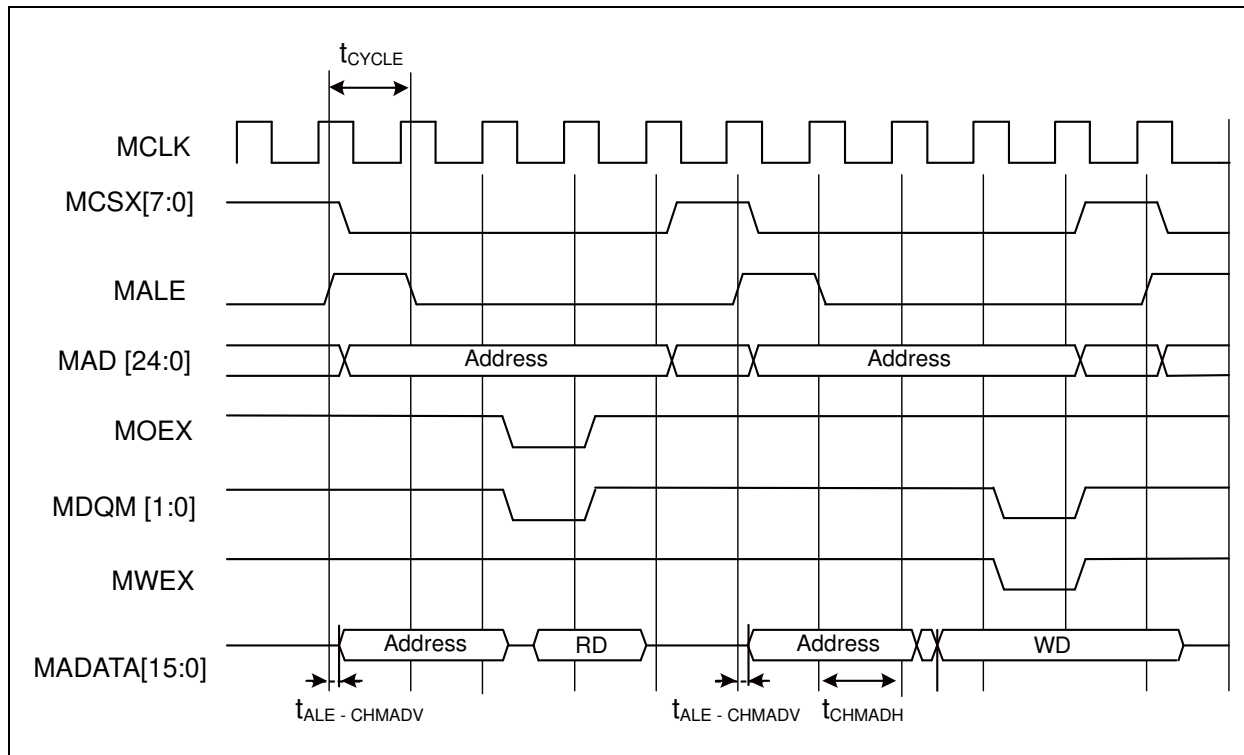

• Multiplexed Bus Access Synchronous SRAM Mode

($V_{CC} = 2.7V$ to $5.5V$, $V_{SS} = 0V$, $T_a = -40^{\circ}C$ to $+105^{\circ}C$)

Parameter	Symbol	Pin name	Conditions	Value		Unit	Remarks
				Min	Max		
MALE delay time	t_{CHAL}	MCLK ALE	$V_{CC} \geq 4.5V$	1	9	ns	
			$V_{CC} < 4.5V$		12		
	t_{CHAH}		$V_{CC} \geq 4.5V$	1	9	ns	
			$V_{CC} < 4.5V$		12		
MCLK $\uparrow \rightarrow$ Multiplexed Address delay time	t_{CHMADV}	MCLK MADATA[15:0]	$V_{CC} \geq 4.5V$	1	t_{OD}	ns	
	$V_{CC} < 4.5V$						
MCLK $\uparrow \rightarrow$ Multiplexed Data output time	t_{CHMADX}		$V_{CC} \geq 4.5V$	1	t_{OD}	ns	
	$V_{CC} < 4.5V$						

Note: When the external load capacitance $C_L = 30pF$.

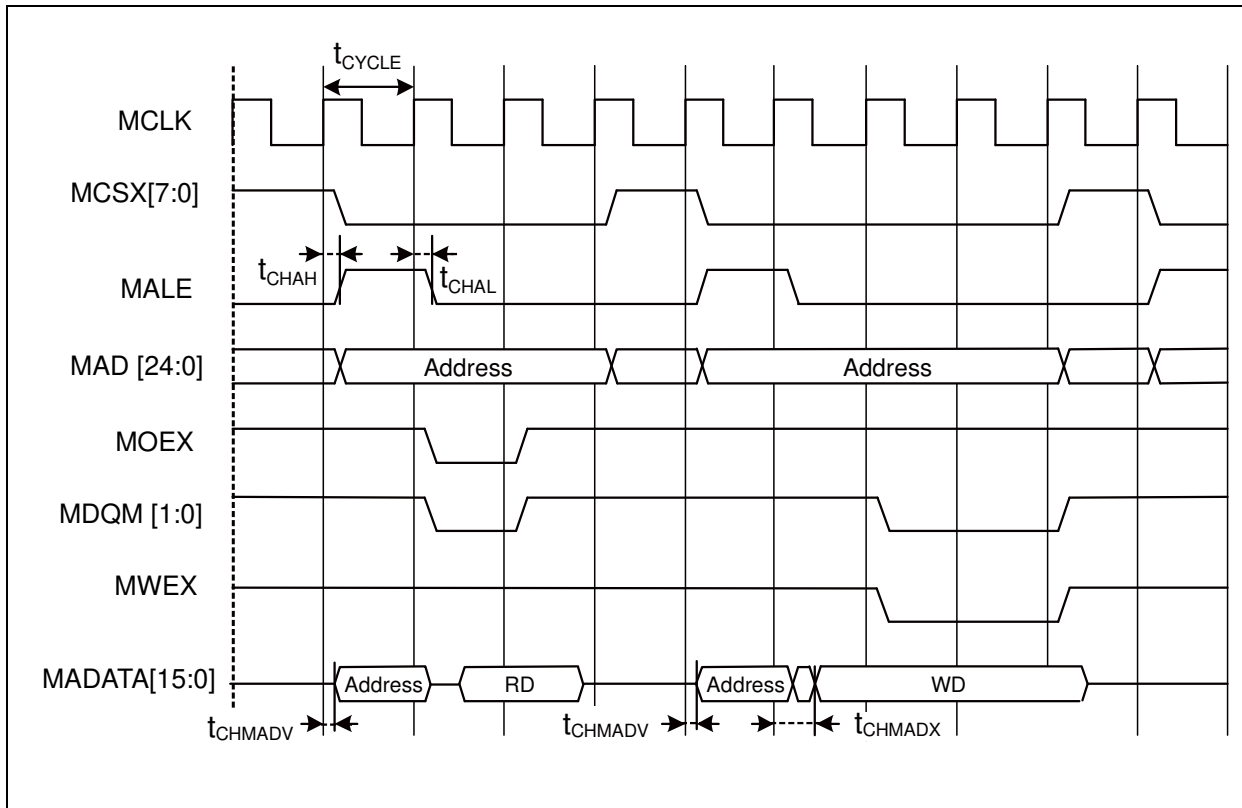

MB9A310A Series

- External Ready Input Timing

($V_{CC} = 2.7V$ to $5.5V$, $V_{SS} = 0V$, $T_a = -40^{\circ}C$ to $+105^{\circ}C$)

Parameter	Symbol	Pin name	Conditions	Value		Unit	Remarks
				Min	Max		
MCLK \uparrow MRDY input setup time	t_{RDYI}	MCLK MRDY	$V_{CC} \geq 4.5V$	19	-	ns	
			$V_{CC} < 4.5V$	37			

- When RDY is input

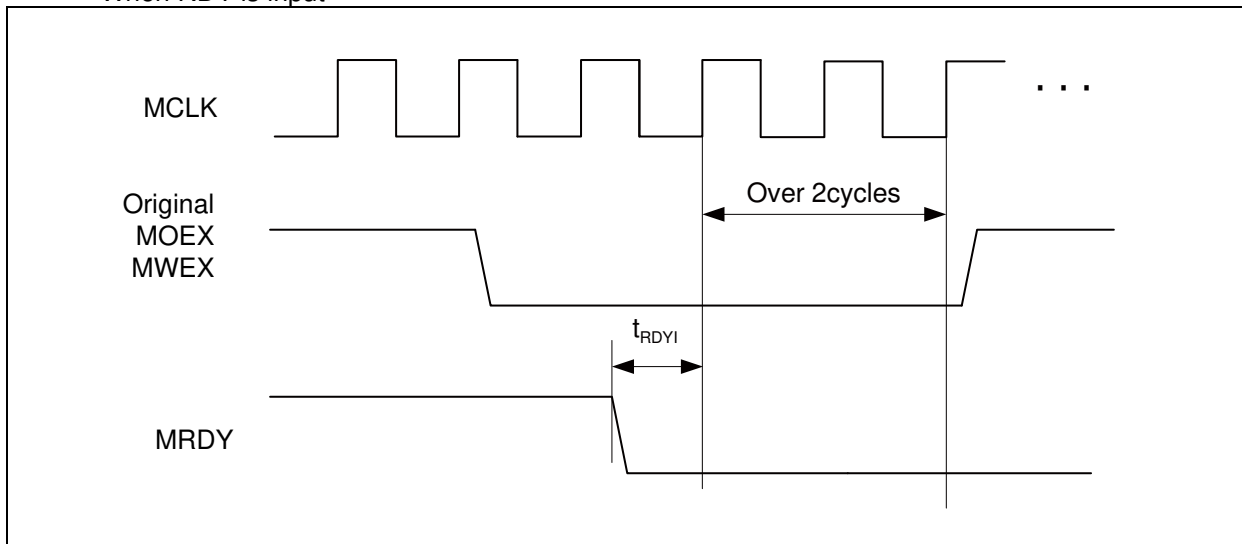

- When RDY is released

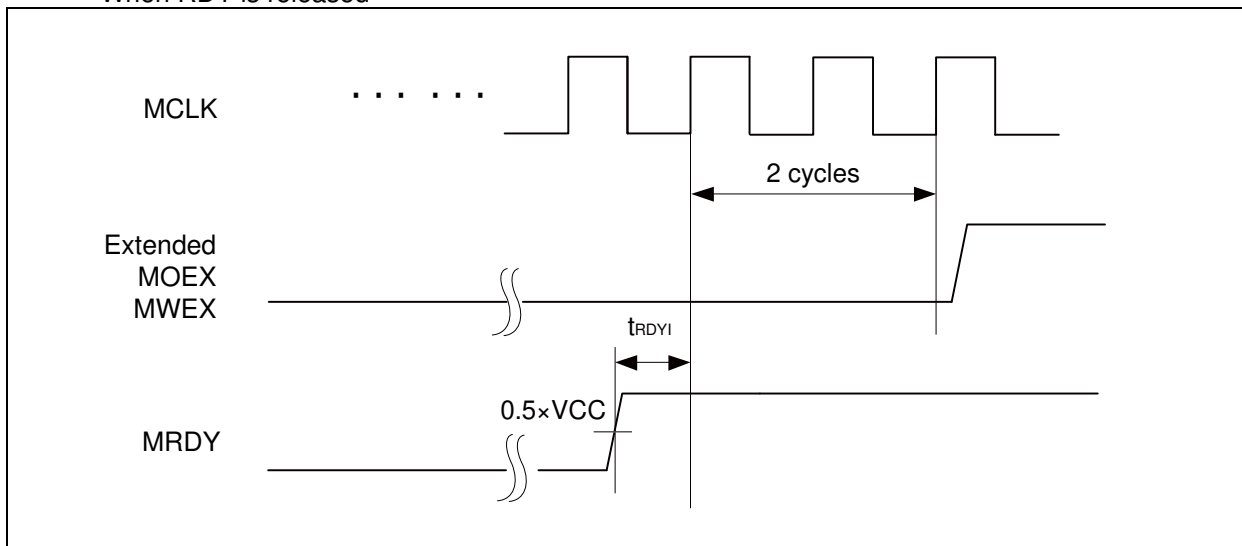

(8) Base Timer Input Timing

- Timer input timing

($V_{CC} = 2.7V$ to $5.5V$, $V_{SS} = 0V$, $T_a = -40^{\circ}C$ to $+105^{\circ}C$)

Parameter	Symbol	Pin name	Conditions	Value		Unit	Remarks
				Min	Max		
Input pulse width	t_{TIWH} t_{TIWL}	TIOAn/TIOBn (when using as ECK, TIN)	-	$2t_{CYCP}$	-	ns	

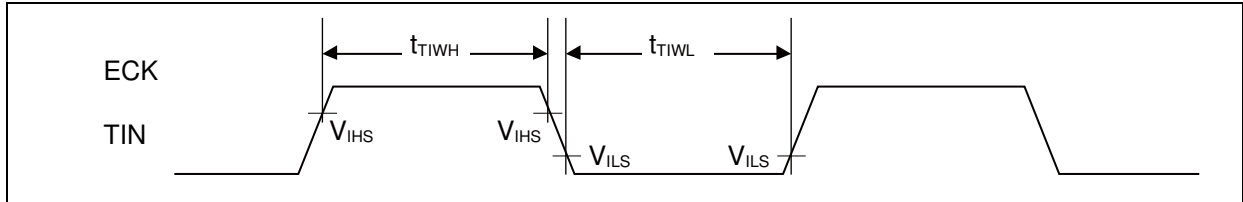

- Trigger input timing

($V_{CC} = 2.7V$ to $5.5V$, $V_{SS} = 0V$, $T_a = -40^{\circ}C$ to $+105^{\circ}C$)

Parameter	Symbol	Pin name	Conditions	Value		Unit	Remarks
				Min	Max		
Input pulse width	t_{TRGH} t_{TRGL}	TIOAn/TIOBn (when using as TGIN)	-	$2t_{CYCP}$	-	ns	

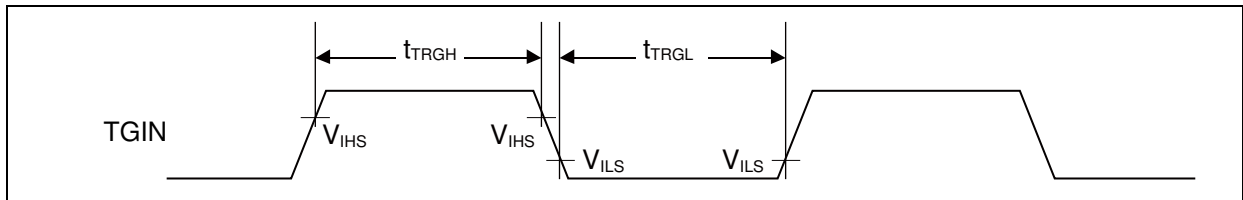

Note: t_{CYCP} indicates the APB bus clock cycle time.

About the APB bus number which the Base Timer is connected to, see "■BLOCK DIAGRAM" in this data sheet.

MB9A310A Series

(9) UART Timing

- Synchronous serial (SPI = 0, SCINV = 0)

(V_{CC} = 2.7V to 5.5V, V_{SS} = 0V, T_a = - 40°C to + 105°C)

Parameter	Symbol	Pin name	Conditions	V _{CC} < 4.5V		V _{CC} ≥ 4.5V		Unit
				Min	Max	Min	Max	
Serial clock cycle time	t _{SCYC}	SCK _X	Internal shift clock operation	4tcycp	-	4tcycp	-	ns
SCK ↓ → SOT delay time	t _{SLOVI}	SCK _X SOT _X		- 30	+ 30	- 20	+ 20	ns
SIN → SCK ↑ setup time	t _{IVSHI}	SCK _X SIN _X		50	-	30	-	ns
SCK ↑ → SIN hold time	t _{SHIXI}	SCK _X SIN _X		0	-	0	-	ns
Serial clock "L" pulse width	t _{SLSH}	SCK _X	External shift clock operation	2tcycp - 10	-	2tcycp - 10	-	ns
Serial clock "H" pulse width	t _{SHSL}	SCK _X		tcycp + 10	-	tcycp + 10	-	ns
SCK ↓ → SOT delay time	t _{SLOVE}	SCK _X SOT _X		-	50	-	30	ns
SIN → SCK ↑ setup time	t _{IVSHE}	SCK _X SIN _X		10	-	10	-	ns
SCK ↑ → SIN hold time	t _{SHIXE}	SCK _X SIN _X		20	-	20	-	ns
SCK falling time	t _F	SCK _X		-	5	-	5	ns
SCK rising time	t _R	SCK _X	-	5	-	5	ns	

- Notes:
- The above characteristics apply to CLK synchronous mode.
 - t_{CYCP} indicates the APB bus clock cycle time.
About the APB bus number which UART is connected to, see "■BLOCK DIAGRAM" in this data sheet.
 - These characteristics only guarantee the same relocate port number.
For example, the combination of SCLK_{x_0} and SOT_{x_1} is not guaranteed.
 - When the external load capacitance CL = 30pF.

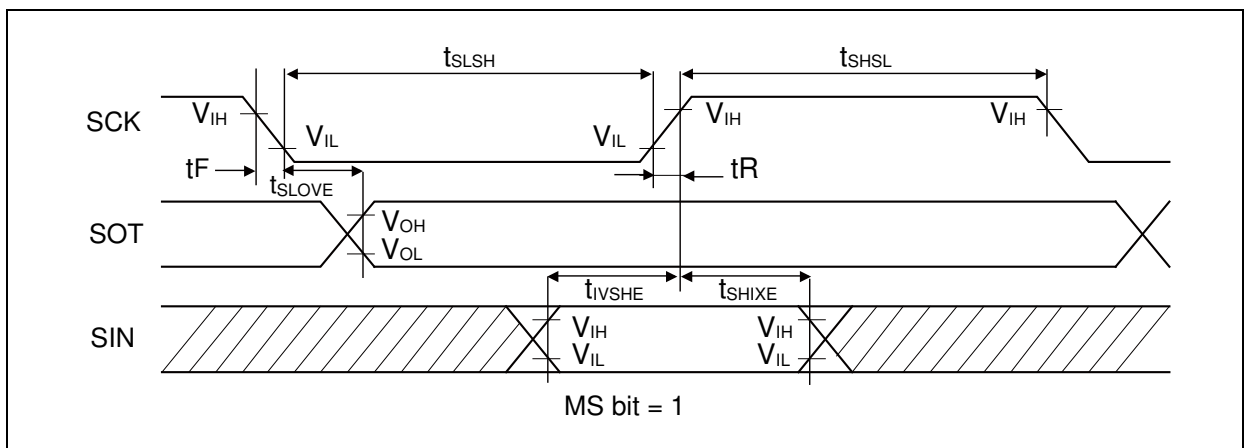
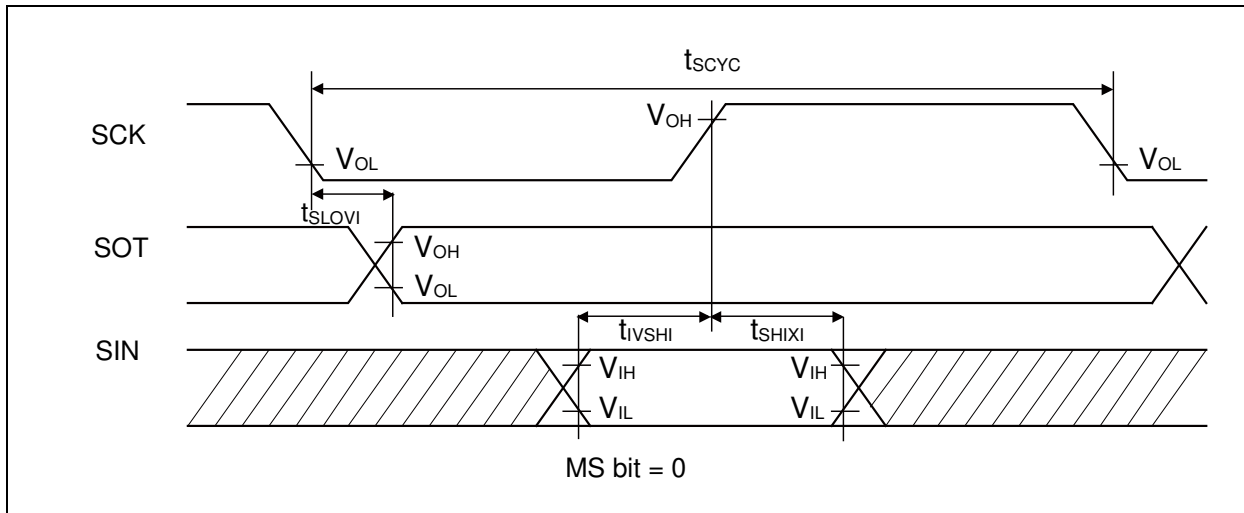

MB9A310A Series

- Synchronous serial (SPI = 0, SCINV = 1)

(Vcc = 2.7V to 5.5V, Vss = 0V, Ta = - 40°C to + 105°C)

Parameter	Symbol	Pin name	Conditions	Vcc < 4.5V		Vcc ≥ 4.5V		Unit
				Min	Max	Min	Max	
Serial clock cycle time	t _{SCYC}	SCKx	Internal shift clock operation	4tcycp	-	4tcycp	-	ns
SCK ↑ → SOT delay time	t _{SHOVI}	SCKx SOTx		- 30	+ 30	- 20	+ 20	ns
SIN → SCK ↓ setup time	t _{IVSLI}	SCKx SINx		50	-	30	-	ns
SCK ↓ → SIN hold time	t _{SLIXI}	SCKx SINx		0	-	0	-	ns
Serial clock "L" pulse width	t _{LSLH}	SCKx	External shift clock operation	2tcycp - 10	-	2tcycp - 10	-	ns
Serial clock "H" pulse width	t _{SHSL}	SCKx		tcycp + 10	-	tcycp + 10	-	ns
SCK ↑ → SOT delay time	t _{SHOVE}	SCKx SOTx		-	50	-	30	ns
SIN → SCK ↓ setup time	t _{IVSLE}	SCKx SINx		10	-	10	-	ns
SCK ↓ → SIN hold time	t _{SLIXE}	SCKx SINx		20	-	20	-	ns
SCK falling time	tF	SCKx		-	5	-	5	ns
SCK rising time	tR	SCKx		-	5	-	5	ns

- Notes:
- The above characteristics apply to CLK synchronous mode.
 - tCYCP indicates the APB bus clock cycle time.
About the APB bus number which UART is connected to, see "■BLOCK DIAGRAM" in this data sheet.
 - These characteristics only guarantee the same relocate port number.
For example, the combination of SCLKx_0 and SOTx_1 is not guaranteed.
 - When the external load capacitance CL = 30pF.

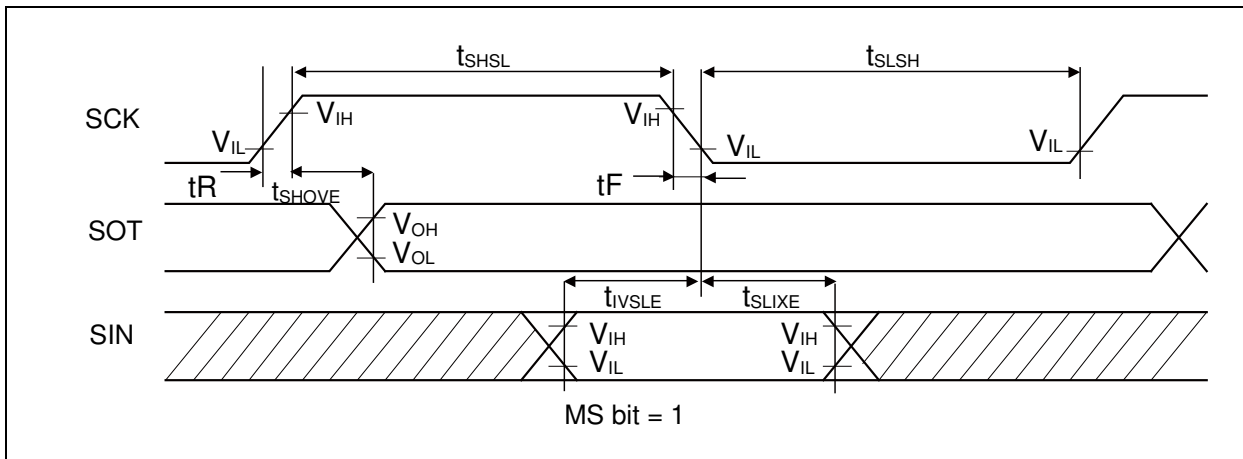
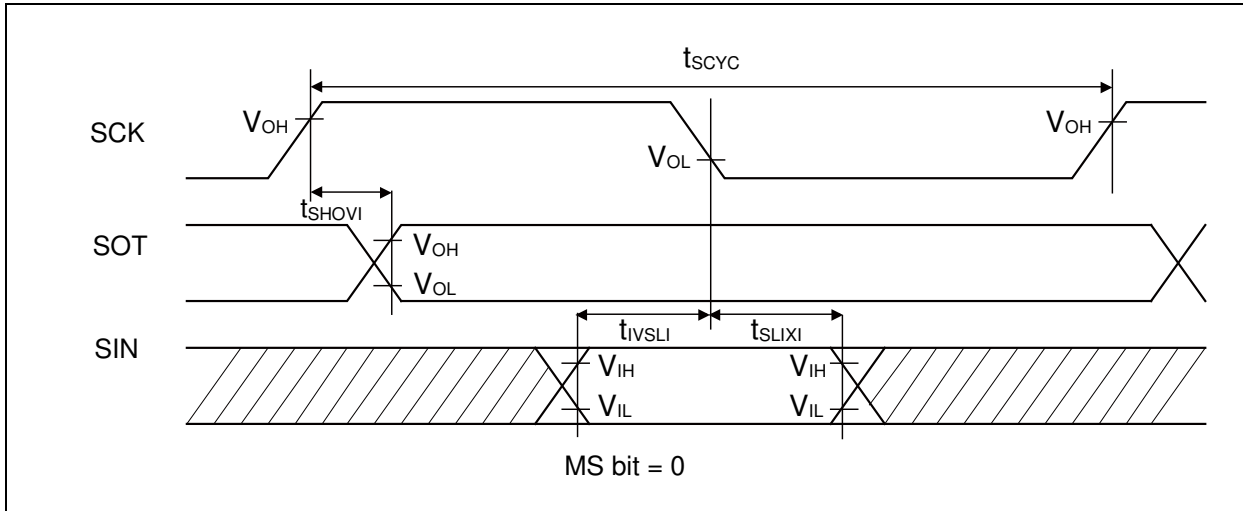

MB9A310A Series

- Synchronous serial(SPI = 1, SCINV = 0)

(Vcc = 2.7V to 5.5V, Vss = 0V, Ta = - 40°C to + 105°C)

Parameter	Symbol	Pin name	Conditions	Vcc < 4.5V		Vcc ≥ 4.5V		Unit
				Min	Max	Min	Max	
Serial clock cycle time	t _{SCYC}	SCK _X	Internal shift clock operation	4tcycp	-	4tcycp	-	ns
SCK ↑ → SOT delay time	t _{SHOVI}	SCK _X SOT _X		- 30	+ 30	- 20	+ 20	ns
SIN → SCK ↓ setup time	t _{IVSLI}	SCK _X SIN _X		50	-	30	-	ns
SCK ↓ → SIN hold time	t _{SLIXI}	SCK _X SIN _X		0	-	0	-	ns
SOT → SCK ↓ delay time	t _{SOVLI}	SCK _X SOT _X		2tcycp - 30	-	2tcycp - 30	-	ns
Serial clock "L" pulse width	t _{SLSH}	SCK _X		2tcycp - 10	-	2tcycp - 10	-	ns
Serial clock "H" pulse width	t _{SHSL}	SCK _X	tcycp + 10	-	tcycp + 10	-	ns	
SCK ↑ → SOT delay time	t _{SHOVE}	SCK _X SOT _X	External shift clock operation	-	50	-	30	ns
SIN → SCK ↓ setup time	t _{IVSLE}	SCK _X SIN _X		10	-	10	-	ns
SCK ↓ → SIN hold time	t _{SLIXE}	SCK _X SIN _X		20	-	20	-	ns
SCK falling time	t _F	SCK _X		-	5	-	5	ns
SCK rising time	t _R	SCK _X		-	5	-	5	ns

- Notes:
- The above characteristics apply to CLK synchronous mode.
 - tCYCP indicates the APB bus clock cycle time.
About the APB bus number which UART is connected to, see "■BLOCK DIAGRAM" in this data sheet.
 - These characteristics only guarantee the same relocate port number.
For example, the combination of SCLK_{x_0} and SOT_{x_1} is not guaranteed.
 - When the external load capacitance C_L = 30pF.

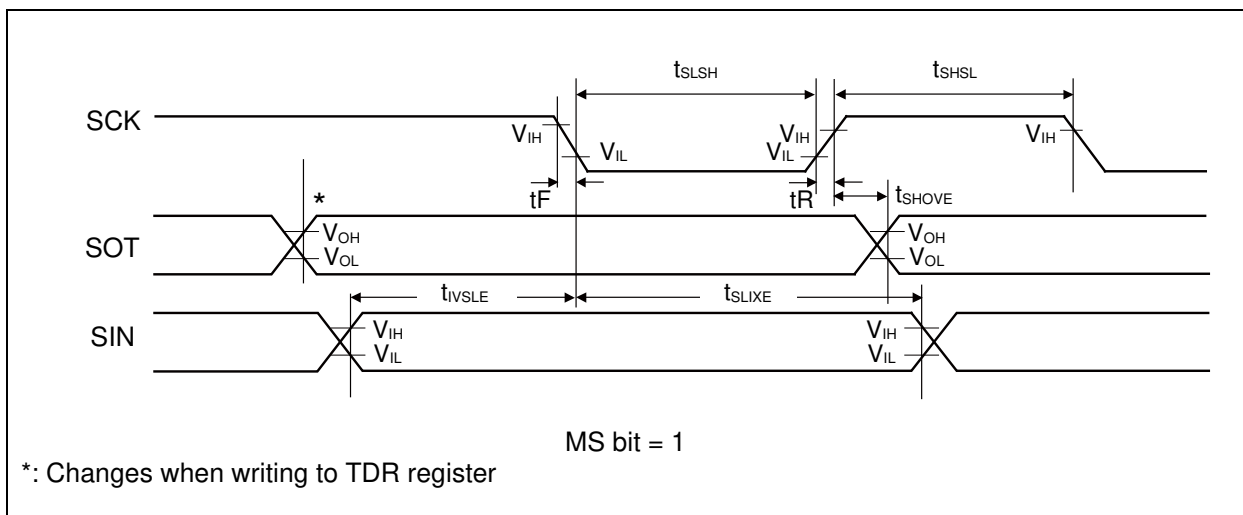
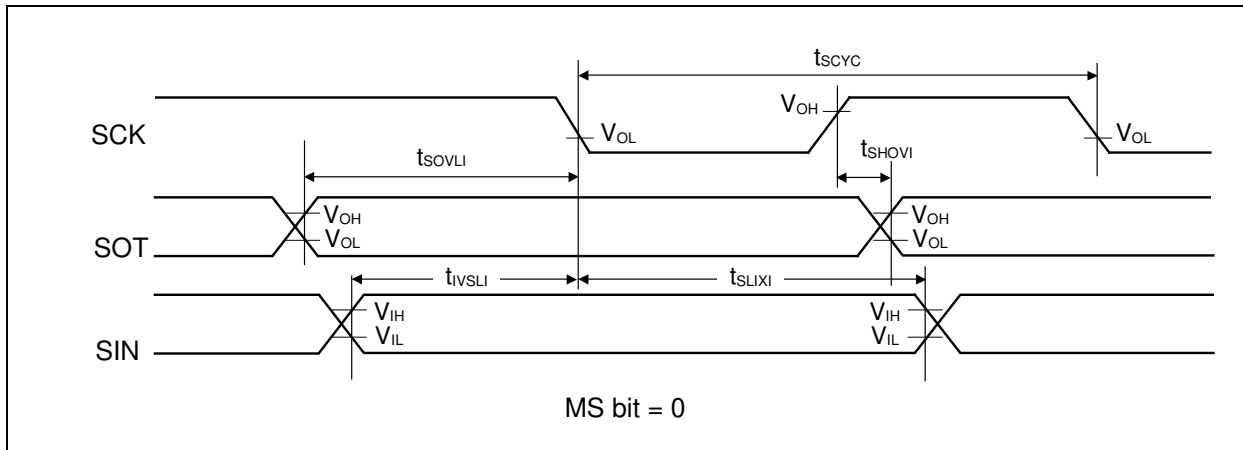

MB9A310A Series

- Synchronous serial (SPI = 1, SCINV = 1)

(V_{CC} = 2.7V to 5.5V, V_{SS} = 0V, T_a = - 40°C to + 105°C)

Parameter	Symbol	Pin name	Conditions	V _{CC} < 4.5V		V _{CC} ≥ 4.5V		Unit
				Min	Max	Min	Max	
Serial clock cycle time	t _{SCYC}	SCK _X	Internal shift clock operation	4tcycp	-	4tcycp	-	ns
SCK ↓ → SOT delay time	t _{SLOVI}	SCK _X SOT _X		- 30	+ 30	- 20	+ 20	ns
SIN → SCK ↑ setup time	t _{IVSHI}	SCK _X SIN _X		50	-	30	-	ns
SCK ↑ → SIN hold time	t _{SHIXI}	SCK _X SIN _X		0	-	0	-	ns
SOT → SCK ↑ delay time	t _{SOVHI}	SCK _X SOT _X		2tcycp - 30	-	2tcycp - 30	-	ns
Serial clock "L" pulse width	t _{SLSH}	SCK _X	External shift clock operation	2tcycp - 10	-	2tcycp - 10	-	ns
Serial clock "H" pulse width	t _{SHSL}	SCK _X		tcycp + 10	-	tcycp + 10	-	ns
SCK ↓ → SOT delay time	t _{SLOVE}	SCK _X SOT _X		-	50	-	30	ns
SIN → SCK ↑ setup time	t _{IVSHE}	SCK _X SIN _X		10	-	10	-	ns
SCK ↑ → SIN hold time	t _{SHIXE}	SCK _X SIN _X		20	-	20	-	ns
SCK falling time	t _F	SCK _X		-	5	-	5	ns
SCK rising time	t _R	SCK _X		-	5	-	5	ns

- Notes:
- The above characteristics apply to CLK synchronous mode.
 - tCYCP indicates the APB bus clock cycle time.
About the APB bus number which UART is connected to, see "■BLOCK DIAGRAM" in this data sheet.
 - These characteristics only guarantee the same relocate port number.
For example, the combination of SCLK_{x_0} and SOT_{x_1} is not guaranteed.
 - When the external load capacitance C_L = 30pF.

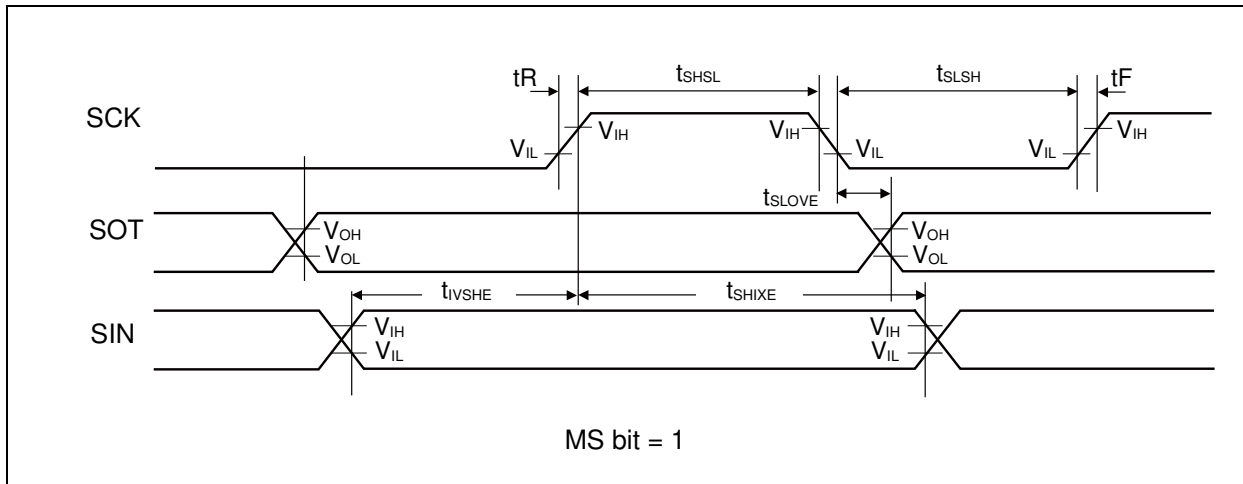
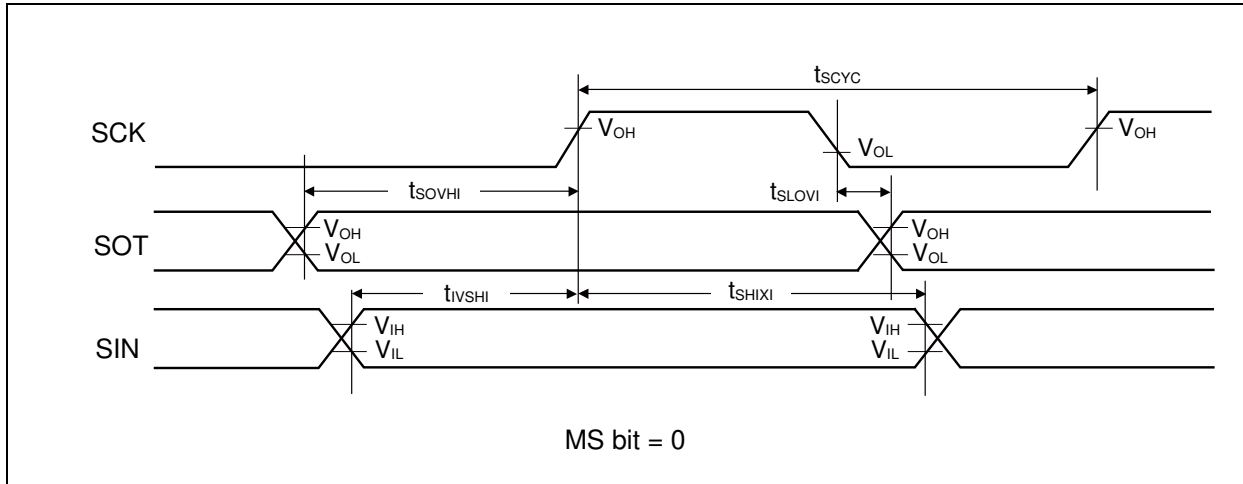

- External clock (EXT = 1) : asynchronous only

($V_{CC} = 2.7V$ to $5.5V$, $V_{SS} = 0V$, $T_a = -40^{\circ}C$ to $+105^{\circ}C$)

Parameter	Symbol	Conditions	Min	Max	Unit	Remarks
Serial clock "L" pulse width	t_{SLSH}	$C_L = 30pF$	$t_{cycp} + 10$	-	ns	
Serial clock "H" pulse width	t_{SHSL}		$t_{cycp} + 10$	-	ns	
SCK falling time	t_F		-	5	ns	
SCK rising time	t_R		-	5	ns	

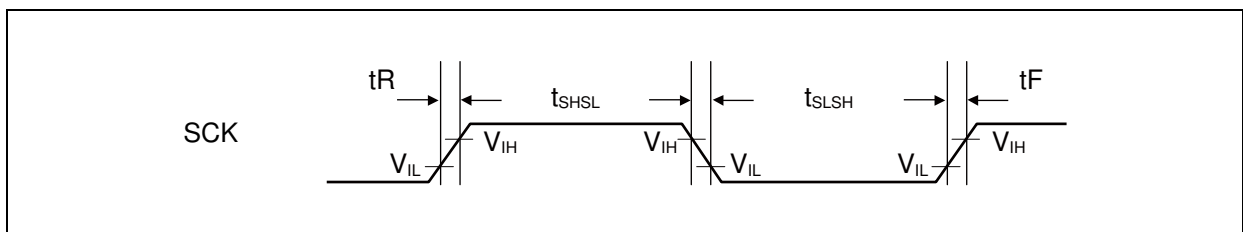

MB9A310A Series

(10) External input timing

(V_{CC} = 2.7V to 5.5V, V_{SS} = 0V, T_a = - 40°C to + 105°C)

Parameter	Symbol	Pin name	Conditions	Value		Unit	Remarks
				Min	Max		
Input pulse width	t _{INH} t _{INL}	ADTG	-	2t _{CYCP} * ¹	-	ns	A/D converter trigger input
		FRCKx					Free-run timer input clock
		ICxx					Input capture
		DTTIXX	-	2t _{CYCP} * ¹	-	ns	Wave form generator
		INT00 to INT15, NMIX	-	2t _{CYCP} + 100* ¹ 500* ²	-	ns	External interrupt NMI

*1 : t_{CYCP} indicates the APB bus clock cycle time except stop when in stop mode, in timer mode.

About the APB bus number which the A/D converter, Multi-function Timer, External interrupt are connected to, see "■BLOCK DIAGRAM" in this data sheet.

*2 : When in stop mode, in timer mode.

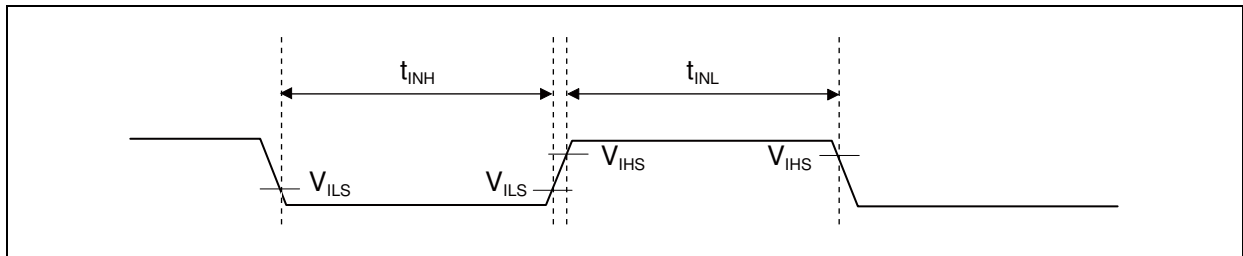

(11) Quadrature Position/Revolution Counter timing

($V_{CC} = 2.7V$ to $5.5V$, $V_{SS} = 0V$, $T_a = -40^{\circ}C$ to $+105^{\circ}C$)

Parameter	Symbol	Conditions	Value		Unit
			Min	Max	
AIN pin "H" width	t_{AHL}	-	$2t_{CYCP}^*$	-	ns
AIN pin "L" width	t_{ALL}	-			
BIN pin "H" width	t_{BHL}	-			
BIN pin "L" width	t_{BLL}	-			
BIN rise time from AIN pin "H" level	t_{AUBU}	PC_Mode2 or PC_Mode3			
AIN fall time from BIN pin "H" level	t_{BUAD}	PC_Mode2 or PC_Mode3			
BIN fall time from AIN pin "L" level	t_{ADBD}	PC_Mode2 or PC_Mode3			
AIN rise time from BIN pin "L" level	t_{BDAU}	PC_Mode2 or PC_Mode3			
AIN rise time from BIN pin "H" level	t_{BUAU}	PC_Mode2 or PC_Mode3			
BIN fall time from AIN pin "H" level	t_{AUBD}	PC_Mode2 or PC_Mode3			
AIN fall time from BIN pin "L" level	t_{BDAD}	PC_Mode2 or PC_Mode3			
BIN rise time from AIN pin "L" level	t_{ADBU}	PC_Mode2 or PC_Mode3			
ZIN pin "H" width	t_{ZHL}	QCR:CGSC = "0"			
ZIN pin "L" width	t_{ZLL}	QCR:CGSC = "0"			
AIN/BIN rise and fall time from determined ZIN level	t_{ZABE}	QCR:CGSC = "1"			
Determined ZIN level from AIN/BIN rise and fall time	t_{ABEZ}	QCR:CGSC = "1"			

* t_{CYCP} indicates the APB bus clock cycle time except stop.

About the APB bus number which Quadrature Position/Revolution Counter is connected to, see "BLOCK DIAGRAM" in this data sheet.

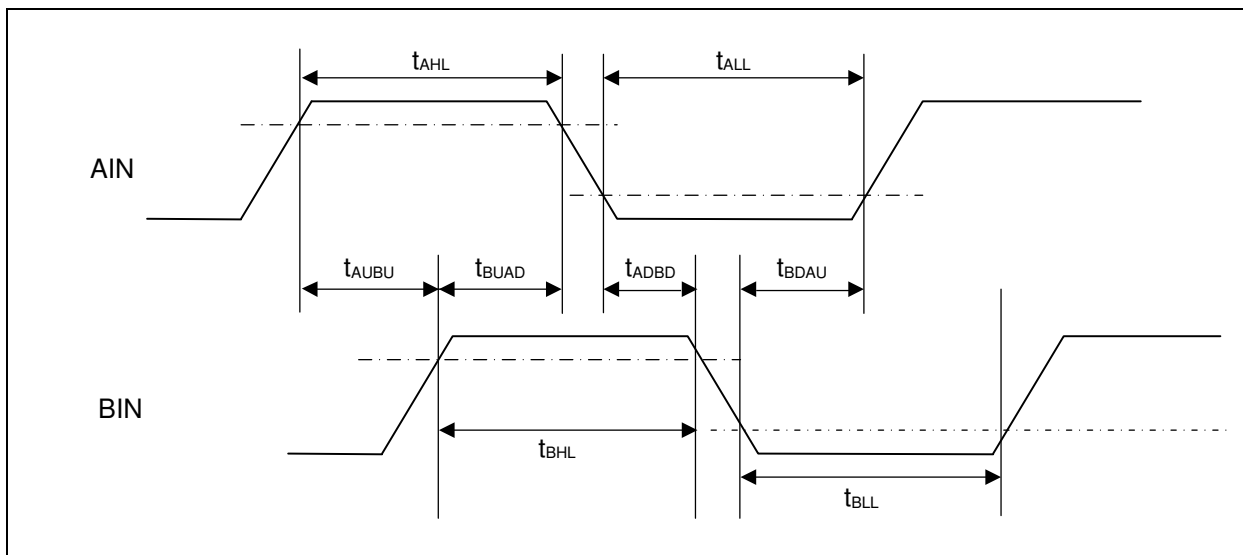

MB9A310A Series

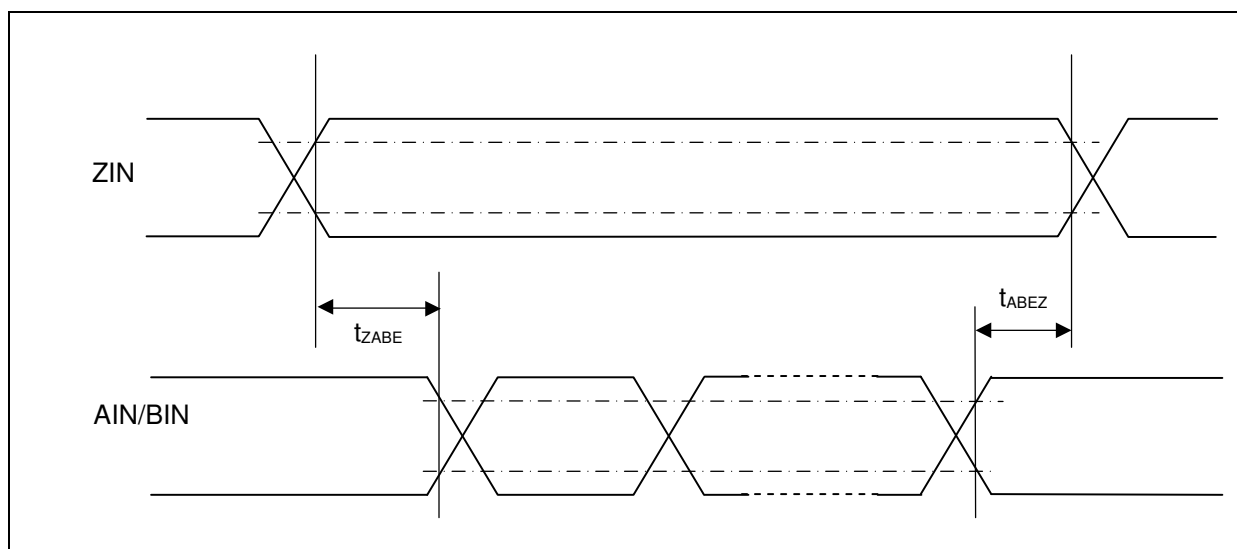
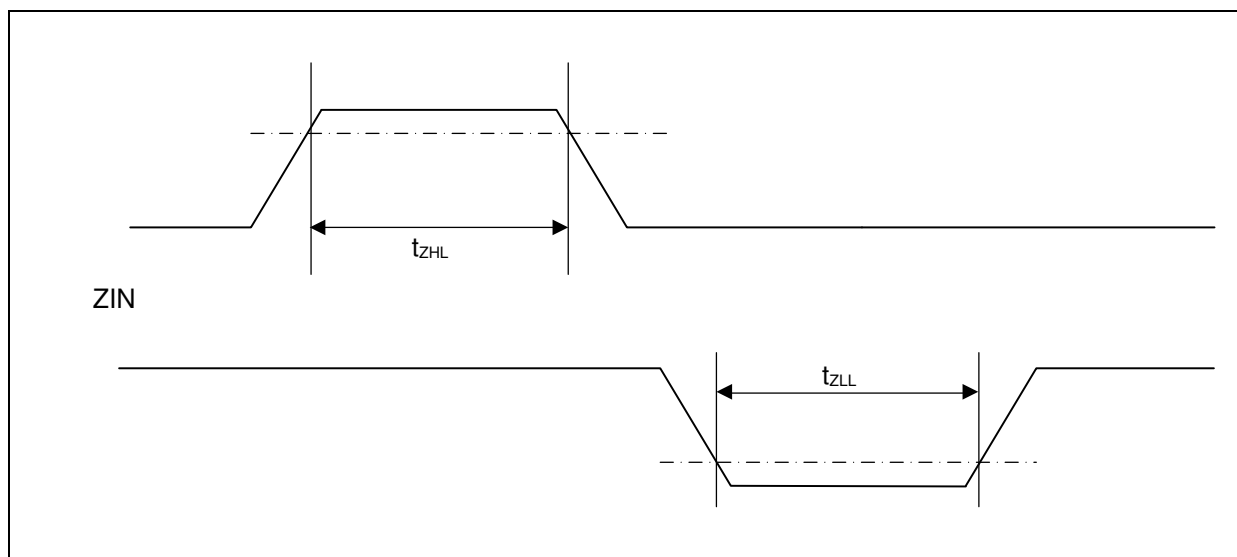
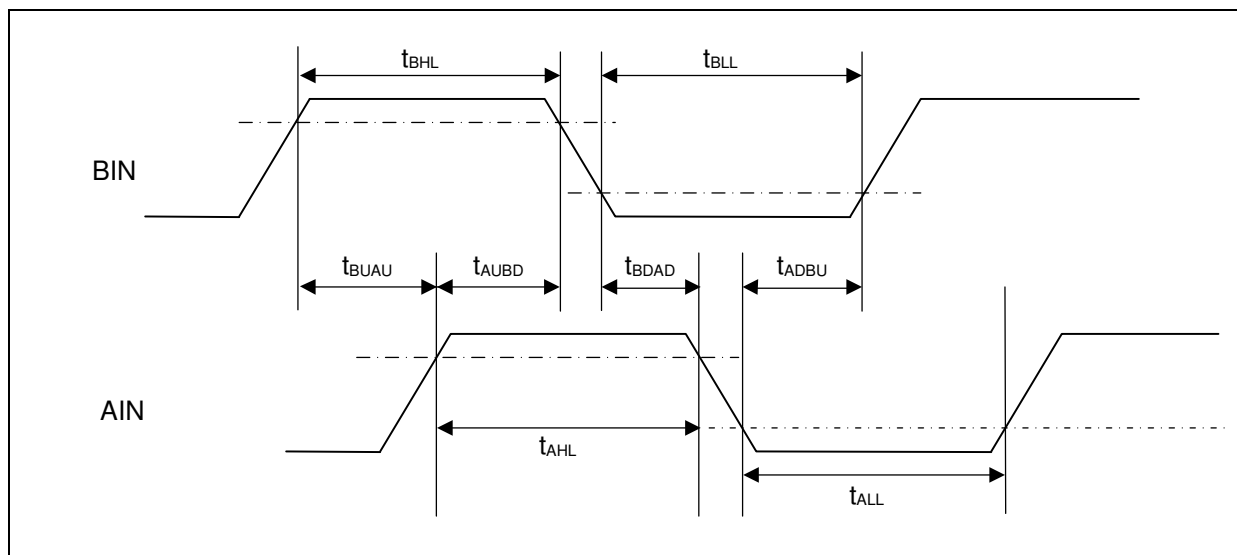

(12) I²C timing

(V_{CC} = 2.7V to 5.5V, V_{SS} = 0V, T_a = - 40°C to + 105°C)

Parameter	Symbol	Conditions	Typical mode		High-speed mode		Unit	Remarks
			Min	Max	Min	Max		
SCL clock frequency	F _{SCL}		0	100	0	400	kHz	
(Repeated) START condition hold time SDA ↓ → SCL ↓	t _{HDSTA}	C _L = 30pF, R = (V _p /I _{OL})* ¹	4.0	-	0.6	-	μs	
SCL clock "L" width	t _{LOW}		4.7	-	1.3	-	μs	
SCL clock "H" width	t _{HIGH}		4.0	-	0.6	-	μs	
(Repeated) START condition setup time SCL ↑ → SDA ↓	t _{SUSTA}		4.7	-	0.6	-	μs	
Data hold time SCL ↓ → SDA ↓ ↑	t _{HDDAT}		0	3.45* ²	0	0.9* ³	μs	
Data setup time SDA ↓ ↑ → SCL ↑	t _{SUDAT}		250	-	100	-	ns	
STOP condition setup time SCL ↑ → SDA ↑	t _{SUSTO}		4.0	-	0.6	-	μs	
Bus free time between "STOP condition" and "START condition"	t _{BUF}		4.7	-	1.3	-	μs	
Noise filter	t _{SP}		-	2 t _{CYCP} * ⁴	-	2 t _{CYCP} * ⁴	-	ns

*1 : R and C represent the pull-up resistor and load capacitance of the SCL and SDA lines, respectively. V_p indicates the power supply voltage of the pull-up resistor and I_{OL} indicates V_{OL} guaranteed current.

*2 : The maximum t_{HDDAT} must satisfy that it does not extend at least "L" period (t_{LOW}) of device's SCL signal.

*3 : A high-speed mode I²C bus device can be used on a standard mode I²C bus system as long as the device satisfies the requirement of "t_{SUDAT} ≥ 250 ns".

*4 : t_{CYCP} is the APB bus clock cycle time.

About the APB bus number that I²C is connected to, see "■BLOCK DIAGRAM" in this data sheet.
To use I²C, set the APB bus clock at 8 MHz or more.

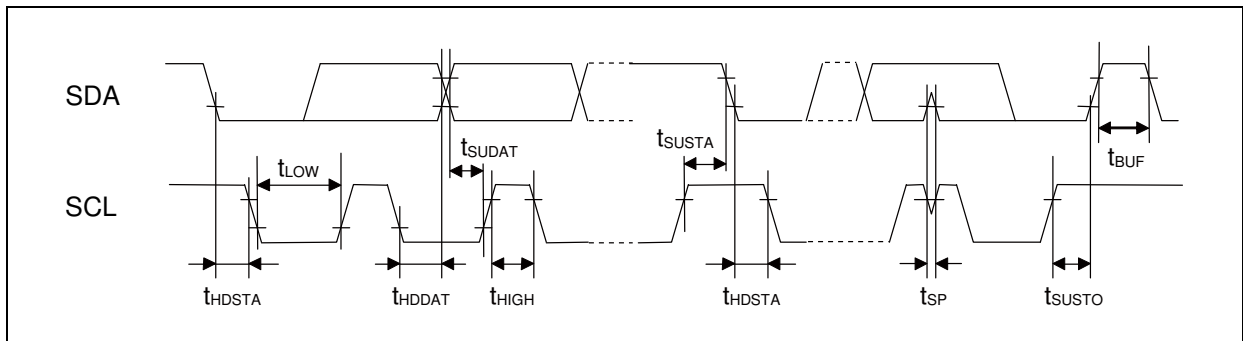

MB9A310A Series

(13) ETM timing

($V_{CC} = 2.7V$ to $5.5V$, $V_{SS} = 0V$, $T_a = -40^{\circ}C$ to $+105^{\circ}C$)

Parameter	Symbol	Pin name	Conditions	Value		Unit	Remarks
				Min	Max		
Data hold	t_{ETMH}	TRACECLK TRACED[3:0]	$V_{CC} \geq 4.5V$	2	9	ns	
			$V_{CC} < 4.5V$	2	15		
TRACECLK frequency	$1/t_{TRACE}$	TRACECLK	$V_{CC} \geq 4.5V$	-	40	MHz	
			$V_{CC} < 4.5V$	-	32	MHz	
TRACECLK Clock cycle time	t_{TRACE}	TRACECLK	$V_{CC} \geq 4.5V$	25	-	ns	
			$V_{CC} < 4.5V$	31.25	-	ns	

Note: When the external load capacitance $C_L = 30pF$.

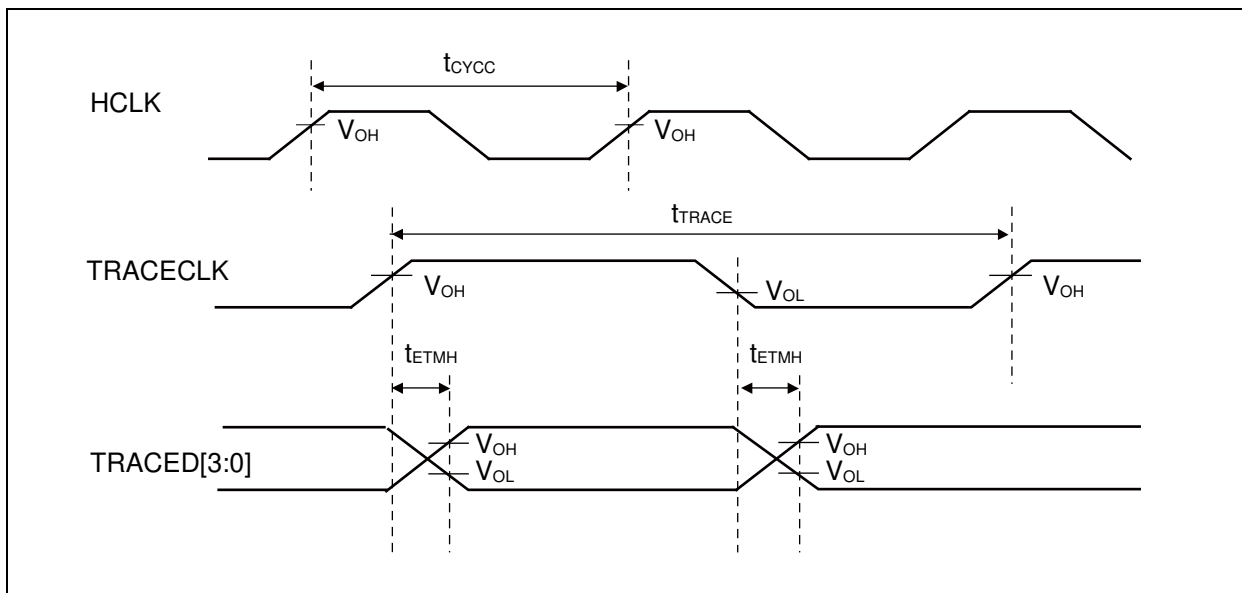

(14) JTAG timing

($V_{CC} = 2.7V$ to $5.5V$, $V_{SS} = 0V$, $T_a = -40^{\circ}C$ to $+105^{\circ}C$)

Parameter	Symbol	Pin name	Conditions	Value		Unit	Remarks
				Min	Max		
TMS, TDI setup time	t_{JTAGS}	TCK TMS,TDI	$V_{CC} \geq 4.5V$	15	-	ns	
			$V_{CC} < 4.5V$				
TMS, TDI hold time	t_{JTAGH}	TCK TMS,TDI	$V_{CC} \geq 4.5V$	15	-	ns	
			$V_{CC} < 4.5V$				
TDO delay time	t_{JTAGD}	TCK TDO	$V_{CC} \geq 4.5V$	-	25	ns	
			$V_{CC} < 4.5V$	-	45		

Note: When the external load capacitance $C_L = 30pF$.

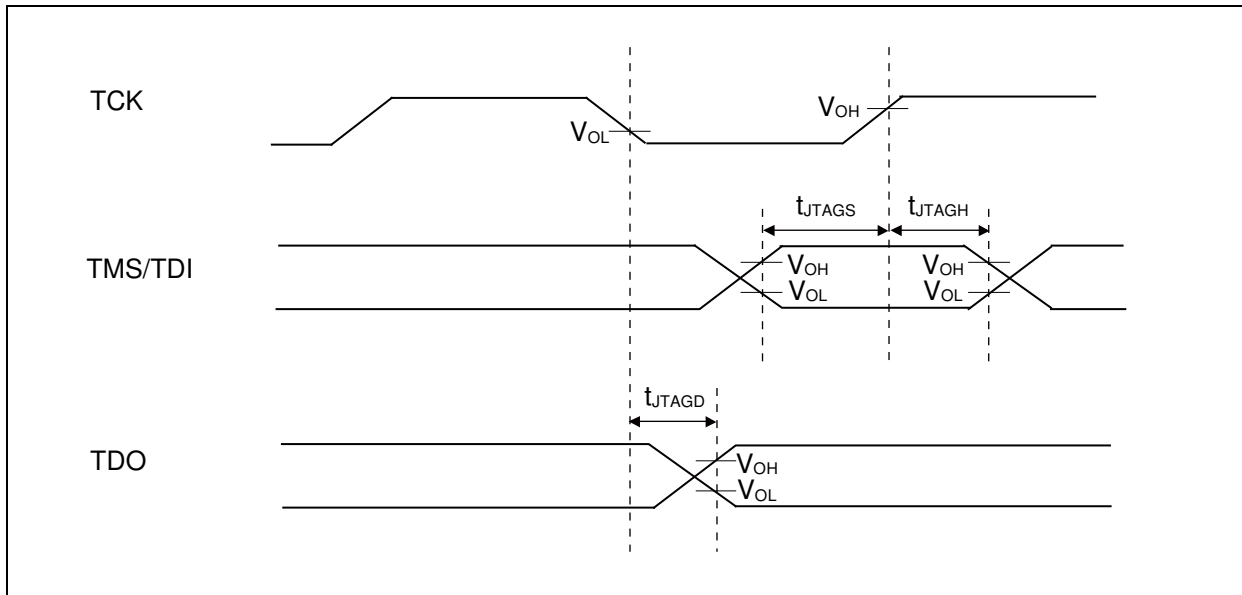

MB9A310A Series

5. 12-bit A/D Converter

· Electrical Characteristics for the A/D Converter

(V_{cc} = AV_{cc} = 2.7V to 5.5V, V_{ss} = AV_{ss} = 0V, T_a = - 40°C to + 105°C)

Parameter	Pin name	Value			Unit	Remarks
		Min	Typ	Max		
Resolution	-	-	-	12	bit	
Non-linearity error	-	- 4.5	-	+ 4.5	LSB	AVRH = 2.7V to 5.5V
Differential linearity error	-	- 2.5	-	+ 2.5	LSB	
Zero transition voltage	AN0 to AN15	- 20	-	+ 20	mV	
Full-scale transition voltage	AN0 to AN15	AVRH-20	-	AVRH+20	mV	
Conversion time	-	1.0* ¹	-	-	μs	AV _{cc} ≥ 4.5V
Sampling time	T _s	*2	-	-	ns	AV _{cc} ≥ 4.5V
		*2	-	-		AV _{cc} < 4.5V
Compare clock cycle* ³	T _{ck}	50	-	2000	ns	
State transition time to operation permission	T _{stt}	1.0	-	-	μs	
Power supply current (analog + digital)	AV _{CC}	-	0.57	0.72	mA	A/D 1unit operation
		-	0.06	20	μA	When A/D stops
Reference power supply current (between AVRH and AVSS)	AVRH	-	1.1	1.96	mA	A/D 1unit operation AVRH = 5.5V
		-	0.06	4	μA	When A/D stops
Analog input capacity	C _{in}	-	-	12.9	pF	
Analog input resistor	R _{in}	-	-	2	kΩ	AV _{cc} ≥ 4.5V
				3.8		AV _{cc} < 4.5V
Interchannel disparity	-	-	-	4	LSB	
Analog port input current	AN0 to AN15	-	-	5	μA	
Analog input voltage	AN0 to AN15	AVSS	-	AVRH	V	
Reference voltage	AVRH	2.7	-	AVCC	V	

*1: The conversion time is the value of sampling time (T_s) + compare time (T_c).

The condition of the minimum conversion time is when the value of sampling time: 300ns, the value of compare time: 700ns (AV_{cc} ≥ 4.5V).

Ensure that it satisfies the value of the sampling time (T_s) and compare clock cycle (T_{ck}).

For setting of the sampling time and compare clock cycle, see "Chapter: A/D Converter" in "FM3 Family PERIPHERAL MANUAL Analog Macro Part".

The A/D Converter register is set at APB bus clock timing. The sampling clock and compare clock are set at Base clock (HCLK).

*2: A necessary sampling time changes by external impedance.

Ensure that it set the sampling time to satisfy (Equation 1)

*3: The compare time (T_c) is the value of (Equation 2)

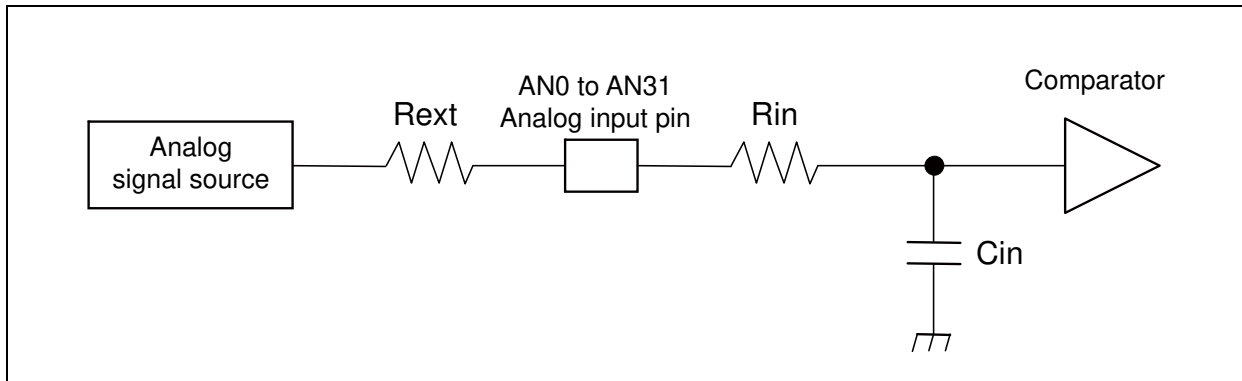

(Equation 1) $T_s \geq (R_{in} + R_{ext}) \times C_{in} \times 9$

T_s : Sampling time

R_{in} : input resistor of A/D = $2\text{k}\Omega$ $4.5 \leq AVCC \leq 5.5$
input resistor of A/D = $3.8\text{k}\Omega$ $2.7 \leq AVCC < 4.5$

C_{in} : input capacity of A/D = 12.9pF $2.7 \leq AVCC \leq 5.5$

R_{ext} : Output impedance of external circuit

(Equation 2) $T_c = T_{cck} \times 14$

T_c : Compare time

T_{cck} : Compare clock cycle

MB9A310A Series

• Definition of 12-bit A/D Converter Terms

- Resolution : Analog variation that is recognized by an A/D converter.
- Linearity error : Deviation of the line between the zero-transition point (0b000000000000 ←→ 0b000000000001) and the full-scale transition point (0b111111111110 ←→ 0b111111111111) from the actual conversion characteristics.
- Differential linearity error : Deviation from the ideal value of the input voltage that is required to change the output code by 1 LSB.

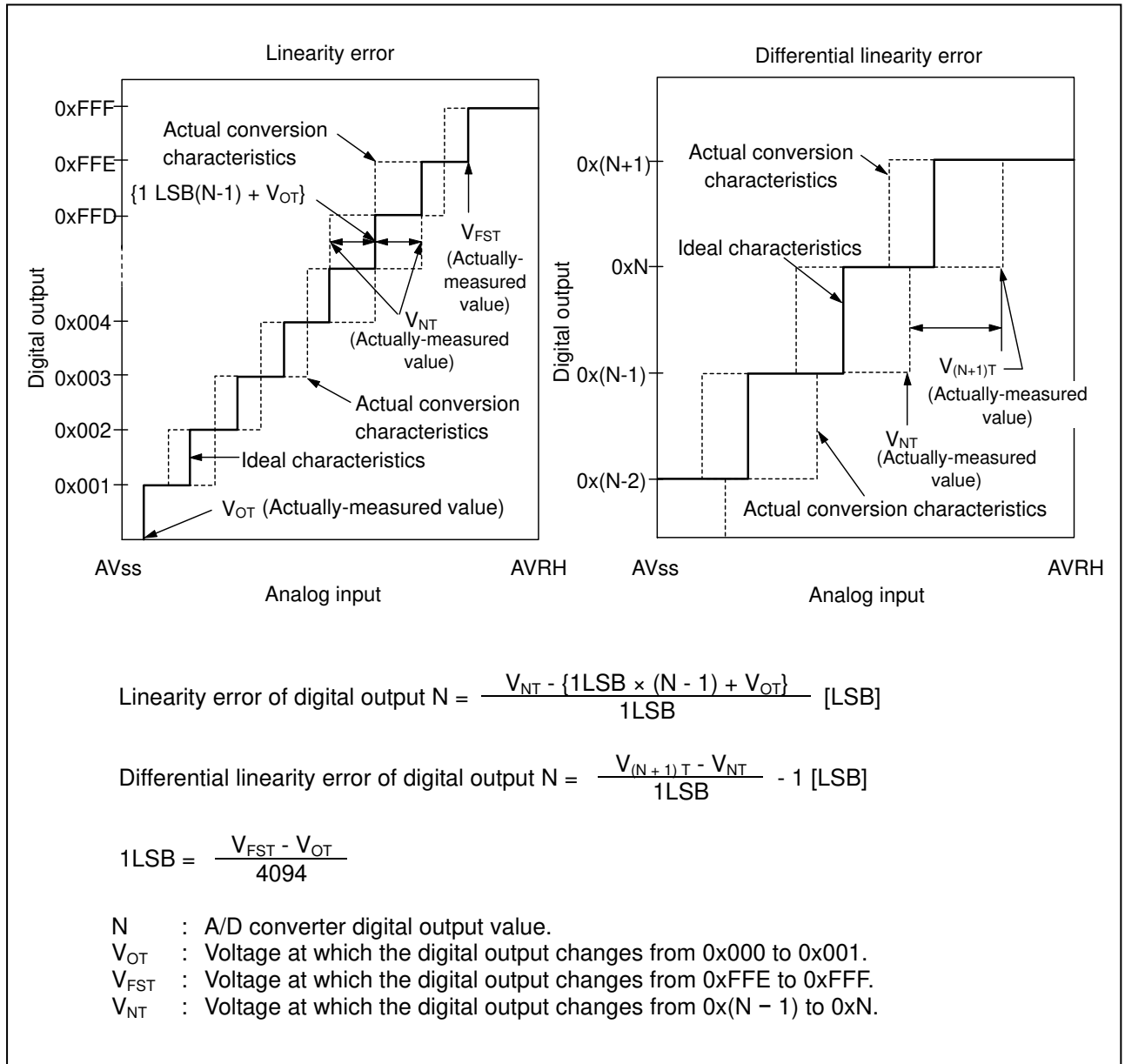

6. USB characteristics

(V_{CC} = 2.7V to 5.5V, USBV_{CC} = 3.0V to 3.6V, V_{SS} = 0V, T_a = - 40°C to + 105°C)

Parameter	Symbol	Pin name	Conditions	Value		Unit	Remarks
				Min	Max		
Input characteristics	Input High level voltage	V _{IH}	-	2.0	USBV _{CC} + 0.3	V	*1
	Input Low level voltage	V _{IL}	-	V _{SS} - 0.3	0.8	V	*1
	Differential input sensitivity	V _{DI}	-	0.2	-	V	*2
	Different common mode range	V _{CM}	-	0.8	2.5	V	*2
Output characteristics	Output High level voltage	V _{OH}	External pull-down resistance = 15kΩ	2.8	3.6	V	*3
	Output Low level voltage	V _{OL}	External pull-up resistance = 1.5kΩ	0.0	0.3	V	*3
	Crossover voltage	V _{CRS}	-	1.3	2.0	V	*4
	Rising time	t _{FR}	Full Speed	4	20	ns	*5
	Falling time	t _{FF}	Full Speed	4	20	ns	*5
	Rise/fall time matching	t _{FRFM}	Full Speed	90	111.11	%	*5
	Output impedance	Z _{DRV}	Full Speed	28	44	Ω	*6
	Rising time	t _{LR}	Low Speed	75	300	ns	*7
	Falling time	t _{LF}	Low Speed	75	300	ns	*7
	Rise/fall time matching	t _{LRFM}	Low Speed	80	125	%	*7

*1 : The switching threshold voltage of Single-End-Receiver of USB I/O buffer is set as within V_{IL} (Max) = 0.8V, V_{IH} (Min) = 2.0 V (TTL input standard).
There are some hysteresis to lower noise sensitivity.

*2 : Use differential-Receiver to receive USB differential data signal.
Differential-Receiver has 200 mV of differential input sensitivity when the differential data input is within 0.8 V to 2.5 V to the local ground reference level.
Above voltage range is the common mode input voltage range.

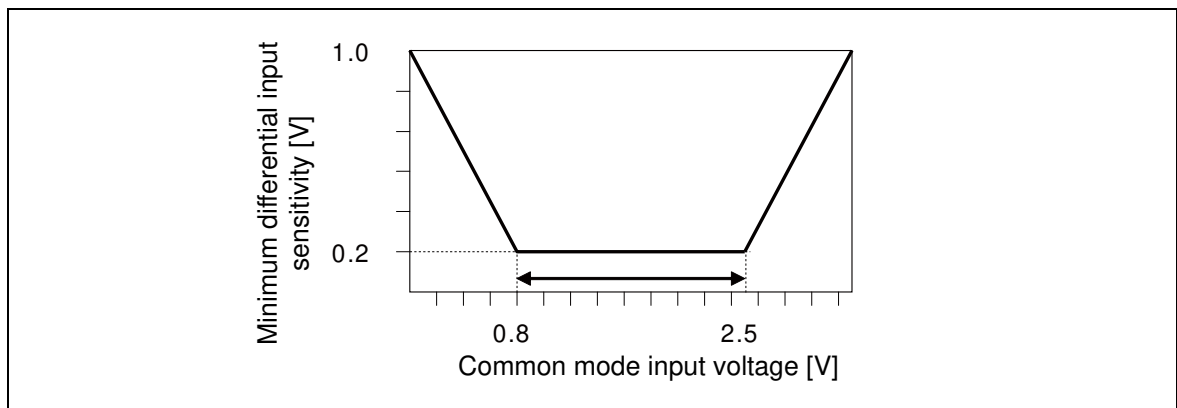

MB9A310A Series

*3 : The output drive capability of the driver is below 0.3 V at Low-State (V_{OL}) (to 3.6 V and 1.5 k Ω load), and 2.8 V or above (to the ground and 1.5 k Ω load) at High-State (V_{OH}).

*4 : The cross voltage of the external differential output signal (D + /D -) of USB I/O buffer is within 1.3 V to 2.0 V.

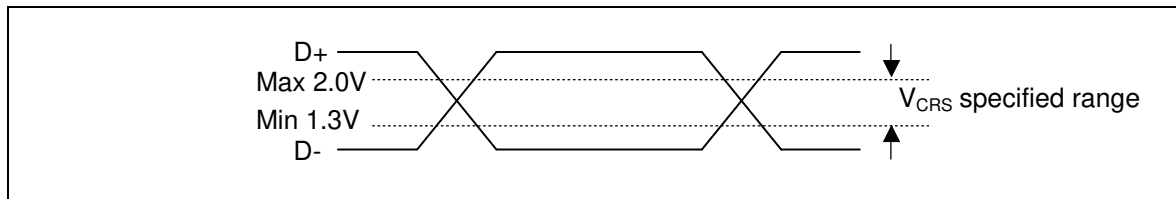

*5 : They indicate rising time (T_{rise}) and falling time (T_{fall}) of the full-speed differential data signal. They are defined by the time between 10% and 90% of the output signal voltage. For full-speed buffer, T_r/T_f ratio is regulated as within $\pm 10\%$ to minimize RFI emission.

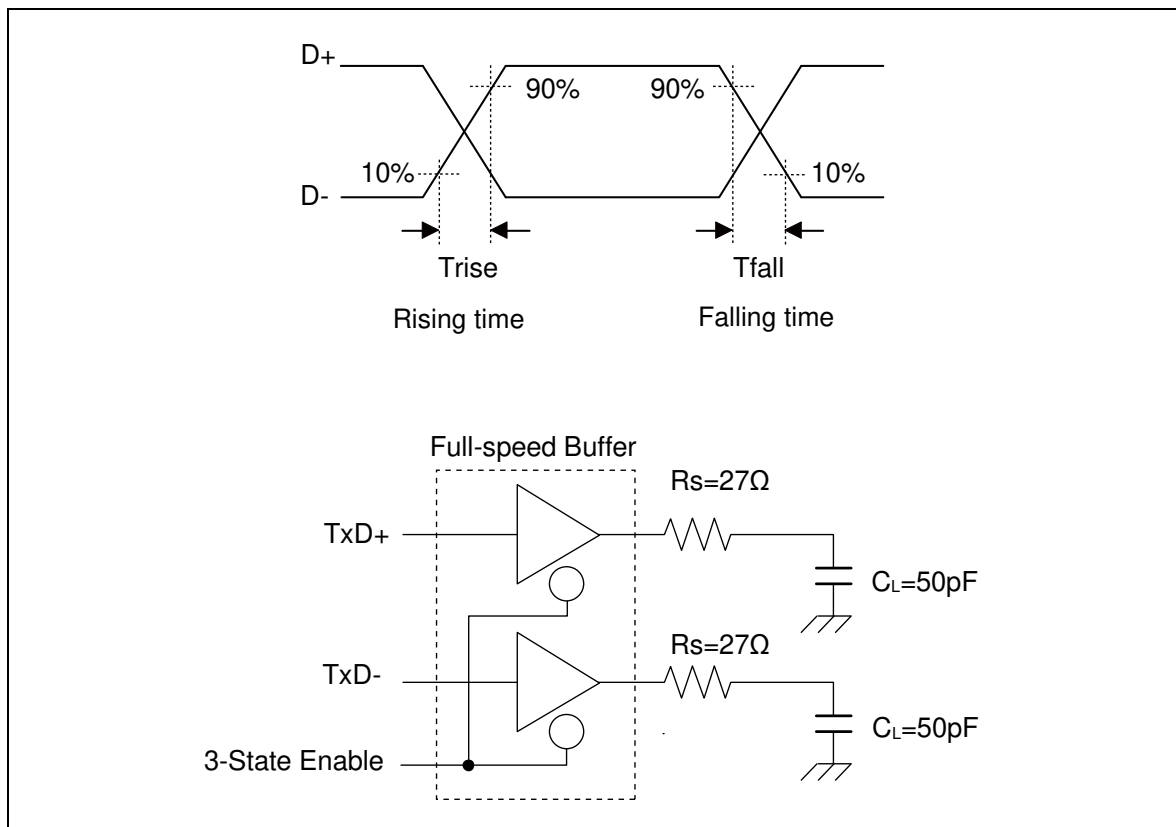

*6 : USB Full-speed connection is performed via twist pair cable shield with $90\Omega \pm 15\%$ characteristic impedance(Differential Mode).

USB standard defines that output impedance of USB driver must be in range from 28Ω to 44Ω . So, discrete series resistor (R_s) addition is defined in order to satisfy the above definition and keep balance.

When using this USB FLS I/O, use it with 25Ω to 30Ω (recommendation value 27Ω) series resistor R_s .

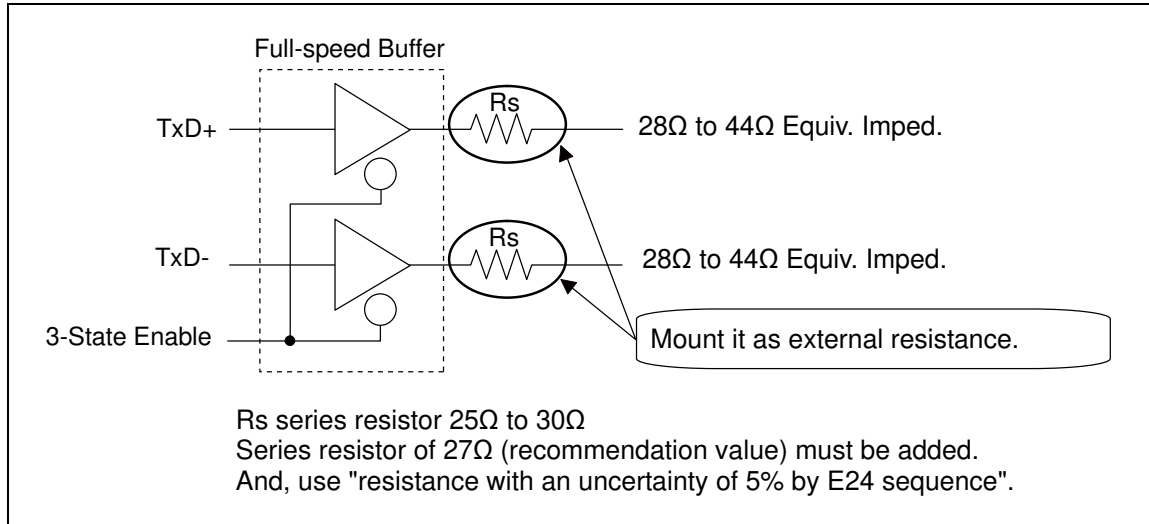

*7 : They indicate rising time (T_{rise}) and falling time (T_{fall}) of the low-speed differential data signal. They are defined by the time between 10% and 90% of the output signal voltage.

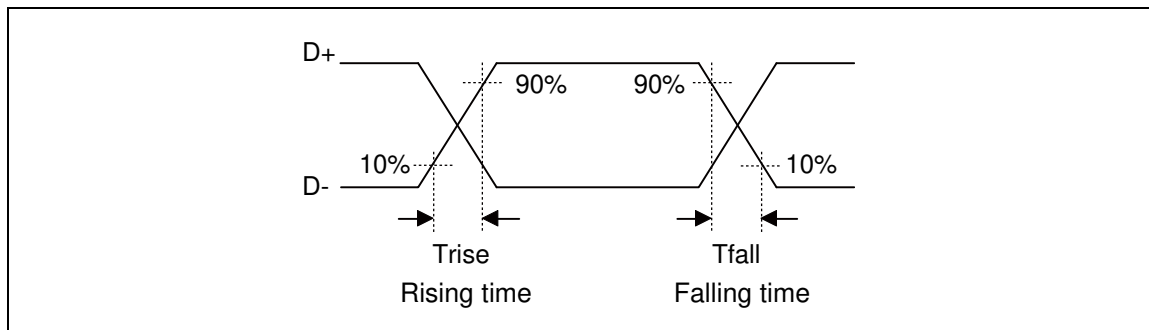

See "· Low-Speed Load (Compliance Load)" for conditions of external load.

MB9A310A Series

- Low-Speed Load (Upstream Port Load) - Reference 1

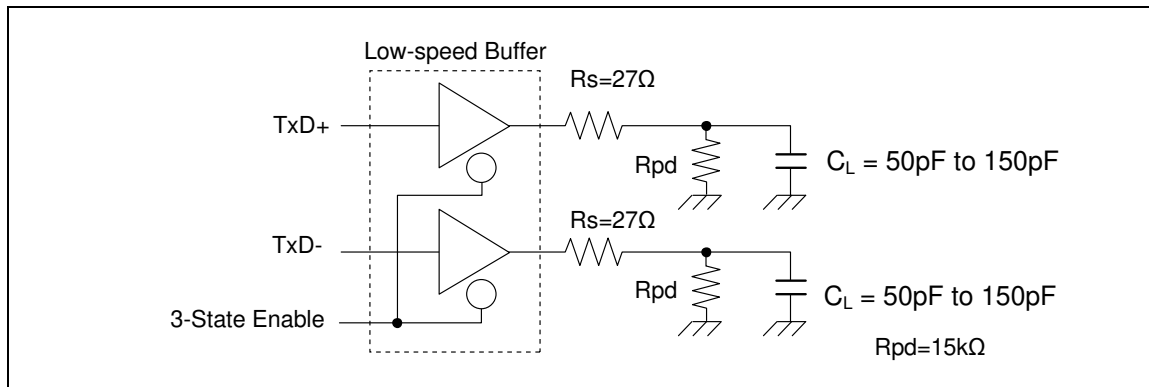

- Low-Speed Load (Downstream Port Load) - Reference 2

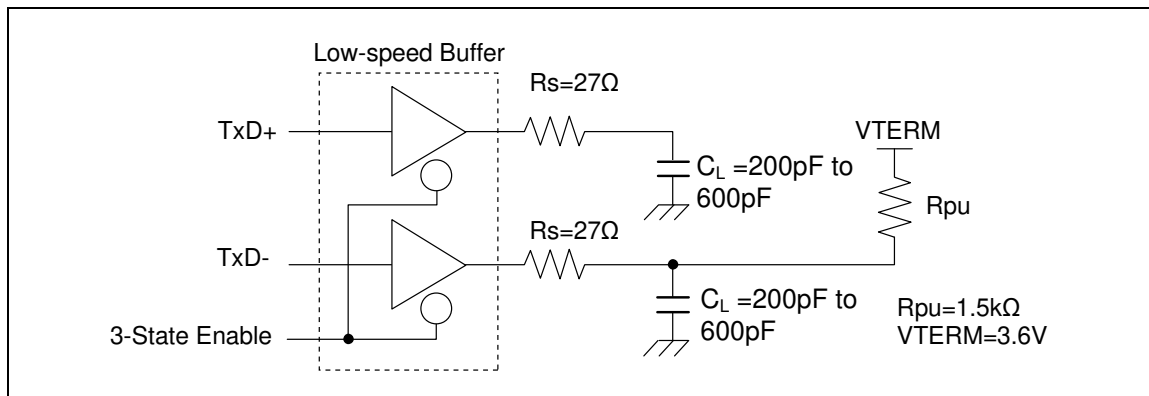

- Low-Speed Load (Compliance Load)

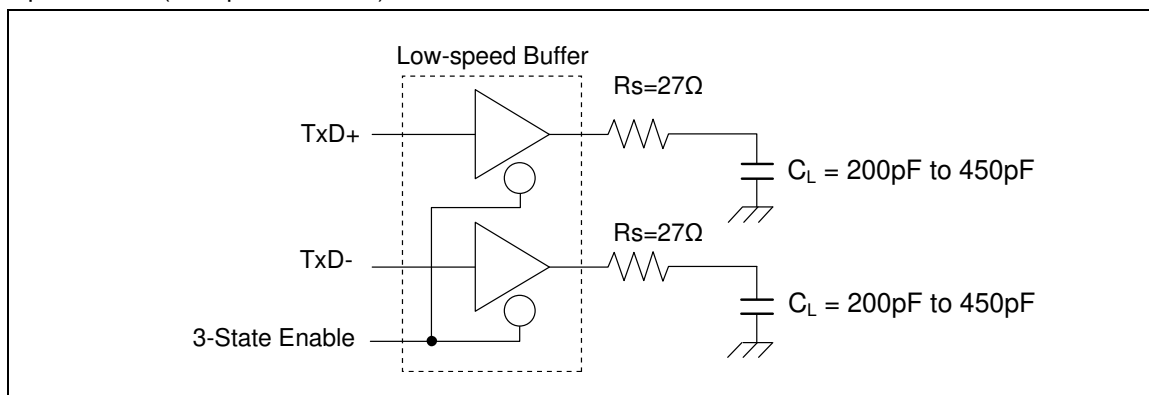

7. Low-voltage detection characteristics

- Low-voltage detection reset

(Ta = - 40°C to + 105°C)

Parameter	Symbol	Conditions	Value			Unit	Remarks
			Min	Typ	Max		
Detected voltage	VDL	-	2.25	2.45	2.65	V	When voltage drops
Released voltage	VDH	-	2.30	2.50	2.70	V	When voltage rises

- Interrupt of low-voltage detection

(Ta = - 40°C to + 105°C)

Parameter	Symbol	Conditions	Value			Unit	Remarks
			Min	Typ	Max		
Detected voltage	VDL	SVHI = 0000	2.58	2.8	3.02	V	When voltage drops
Released voltage	VDH		2.67	2.9	3.13	V	When voltage rises
Detected voltage	VDL	SVHI = 0001	2.76	3.0	3.24	V	When voltage drops
Released voltage	VDH		2.85	3.1	3.34	V	When voltage rises
Detected voltage	VDL	SVHI = 0010	2.94	3.2	3.45	V	When voltage drops
Released voltage	VDH		3.04	3.3	3.56	V	When voltage rises
Detected voltage	VDL	SVHI = 0011	3.31	3.6	3.88	V	When voltage drops
Released voltage	VDH		3.40	3.7	3.99	V	When voltage rises
Detected voltage	VDL	SVHI = 0100	3.40	3.7	3.99	V	When voltage drops
Released voltage	VDH		3.50	3.8	4.10	V	When voltage rises
Detected voltage	VDL	SVHI = 0111	3.68	4.0	4.32	V	When voltage drops
Released voltage	VDH		3.77	4.1	4.42	V	When voltage rises
Detected voltage	VDL	SVHI = 1000	3.77	4.1	4.42	V	When voltage drops
Released voltage	VDH		3.86	4.2	4.53	V	When voltage rises
Detected voltage	VDL	SVHI = 1001	3.86	4.2	4.53	V	When voltage drops
Released voltage	VDH		3.96	4.3	4.64	V	When voltage rises
LVD stabilization wait time	T _{LVDW}	-	-	-	2240 × t _{cycp} *	μs	

* : t_{cycp} indicates the APB2 bus clock cycle time.

MB9A310A Series

8. Flash Memory Write/Erase Characteristics

(V_{cc} = 2.7V to 5.5V, T_a = - 40°C to + 105°C)

Parameter		Value			Value	Remarks
		Min	Typ	Max		
Sector erase time	Large Sector	-	0.7	3.7	s	Includes write time prior to internal erase
	Small Sector		0.3	1.1		
Half word (16 bit) write time		-	12	384	μs	Not including system-level overhead time.
Chip erase time	64K/128K/256KByte	-	5.2	23.6	s	Includes write time prior to internal erase
	384K/512KByte		8	38.4	s	

Write cycles and data hold time

Erase/write cycles (cycle)	Data hold time (year)	Remarks
1,000	20*	
10,000	10*	
100,000	5*	

*:This value comes from the technology qualification (using Arrhenius equation to translate high temperature acceleration test result into average temperature value at + 85°C) .

MB9A310A Series

■ ORDERING INFORMATION

Part number	Package
MB9AF311LAPMC1	Plastic • LQFP(0.5mm pitch),64-pin (FPT-64P-M24/M38)
MB9AF312LAPMC1	
MB9AF314LAPMC1	
MB9AF311LAPMC	Plastic • LQFP(0.65mm pitch),64-pin (FPT-64P-M23/M39)
MB9AF312LAPMC	
MB9AF314LAPMC	
MB9AF311LAQN	Plastic • QFN(0.5mm pitch),64-pin (LCC-64P-M24)
MB9AF312LAQN	
MB9AF314LAQN	
MB9AF311MAPMC	Plastic • LQFP(0.5mm pitch),80-pin (FPT-80P-M21/M37)
MB9AF312MAPMC	
MB9AF314MAPMC	
MB9AF315MAPMC	
MB9AF316MAPMC	
MB9AF311NAPMC	Plastic • LQFP(0.5mm pitch),100-pin (FPT-100P-M20/M23)
MB9AF312NAPMC	
MB9AF314NAPMC	
MB9AF315NAPMC	
MB9AF316NAPMC	
MB9AF311NAPF	Plastic • QFP(0.65mm pitch), 100-pin (FPT-100P-M06)
MB9AF312NAPF	
MB9AF314NAPF	
MB9AF315NAPF	
MB9AF316NAPF	
MB9AF311NABGL	Plastic • PFBGA(0.8mm pitch),112-pin (BGA-112P-M04)
MB9AF312NABGL	
MB9AF314NABGL	

MB9A310A Series

■ PACKAGE DIMENSIONS

<p>100-pin plastic LQFP</p> <p>(FPT-100P-M20)</p>	Lead pitch	0.50 mm
	Package width × package length	14.0 mm × 14.0 mm
	Lead shape	Gullwing
	Sealing method	Plastic mold
	Mounting height	1.70 mm Max
	Weight	0.65 g
	Code (Reference)	P-LFQFP100-14×14-0.50

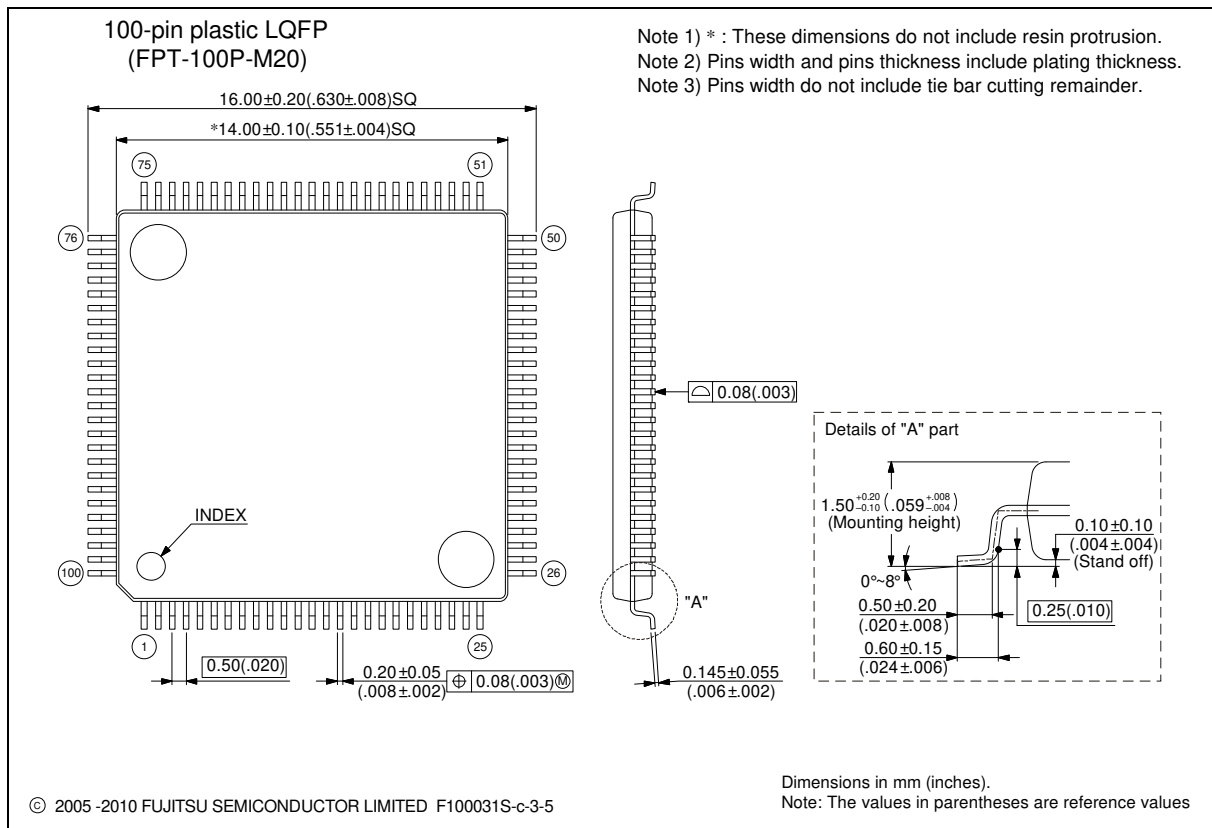

Please check the latest package dimension at the following URL.
<http://edevice.fujitsu.com/package/en-search/>

MB9A310A Series

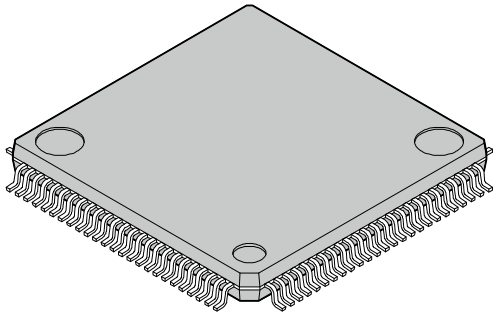
<p>100-pin plastic LQFP</p>  <p>(FPT-100P-M23)</p>	Lead pitch	0.50 mm
	Package width × package length	14.00 mm × 14.00 mm
	Lead shape	Gullwing
	Lead bend direction	Normal bend
	Sealing method	Plastic mold
	Mounting height	1.70 mm MAX
	Weight	0.65 g

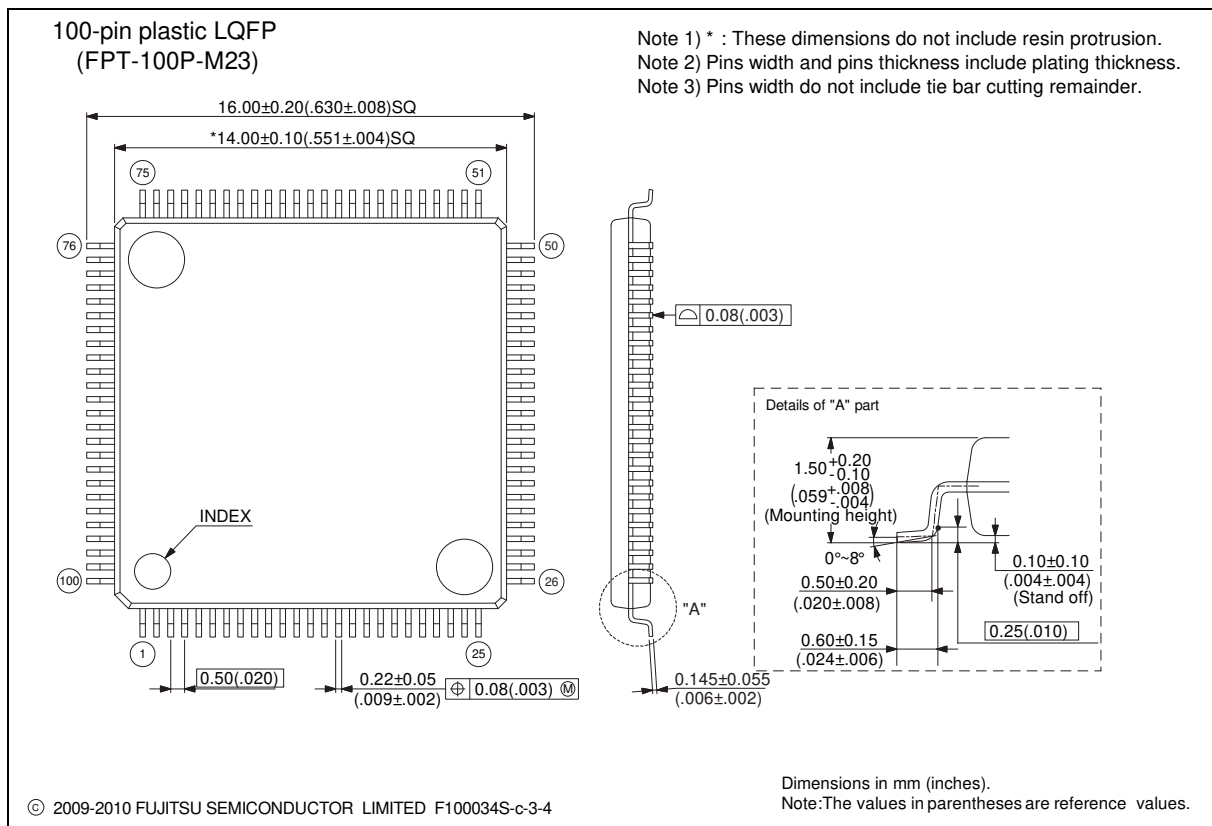

Please check the latest package dimension at the following URL.
<http://edevic.fujitsu.com/package/en-search/>

MB9A310A Series

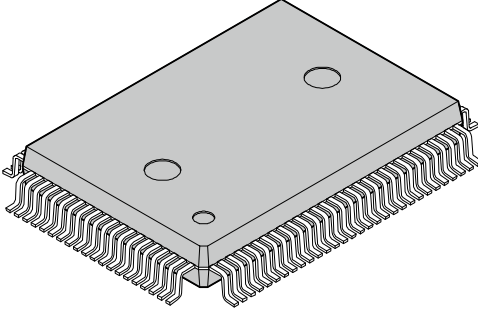
<p>100-pin plastic QFP</p>  <p>(FPT-100P-M06)</p>	Lead pitch	0.65 mm
	Package width × package length	14.00 × 20.00 mm
	Lead shape	Gullwing
	Sealing method	Plastic mold
	Mounting height	3.35 mm MAX
	Code (Reference)	P-QFP100-14×20-0.65

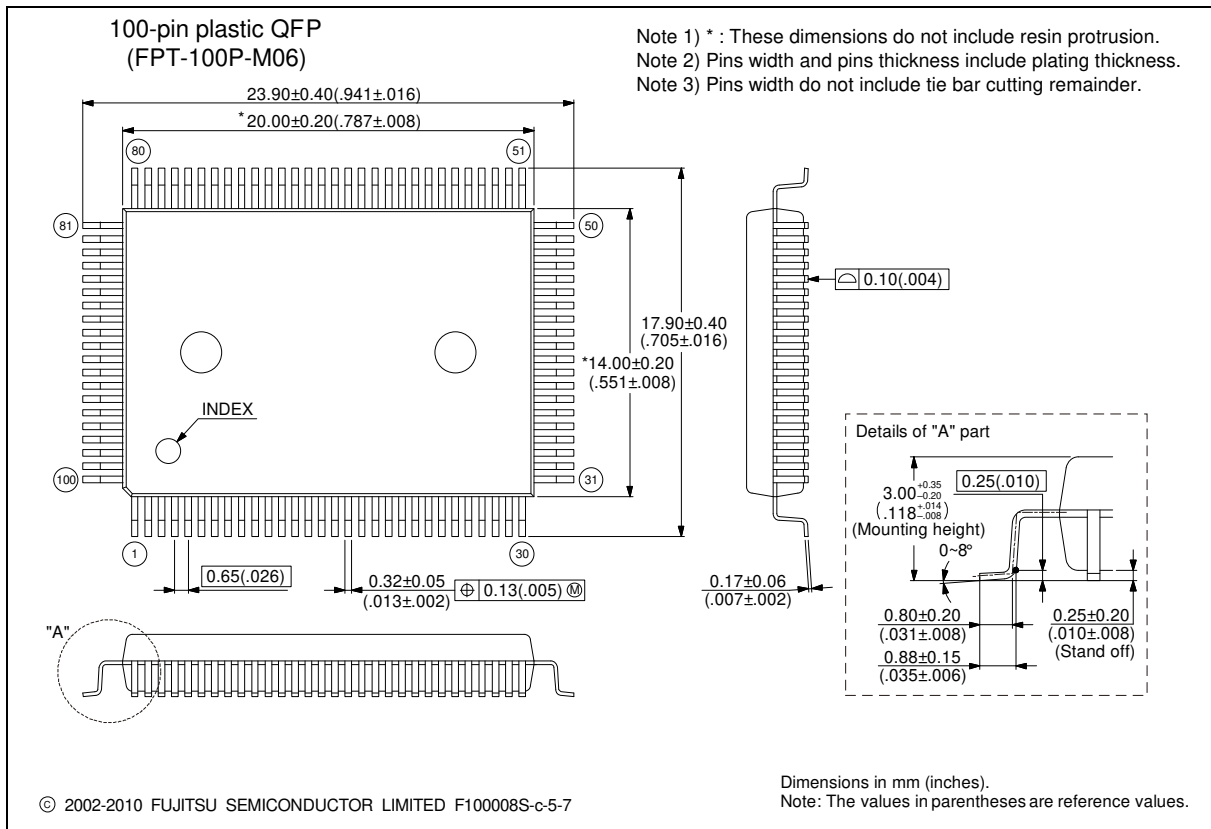

Please check the latest package dimension at the following URL.
<http://edevic.fujitsu.com/package/en-search/>

MB9A310A Series

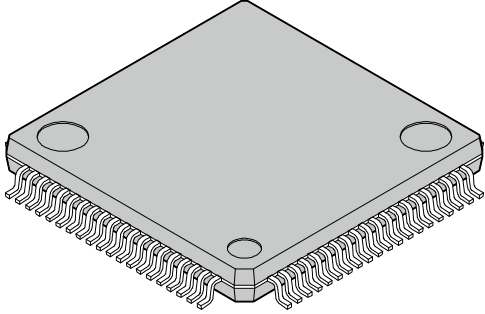
<p>80-pin plastic LQFP</p>  <p>(FPT-80P-M21)</p>	Lead pitch	0.50 mm
	Package width × package length	12 mm × 12 mm
	Lead shape	Gullwing
	Sealing method	Plastic mold
	Mounting height	1.70 mm Max
	Weight	0.47 g
	Code (Reference)	P-LFQFP80-12×12-0.50

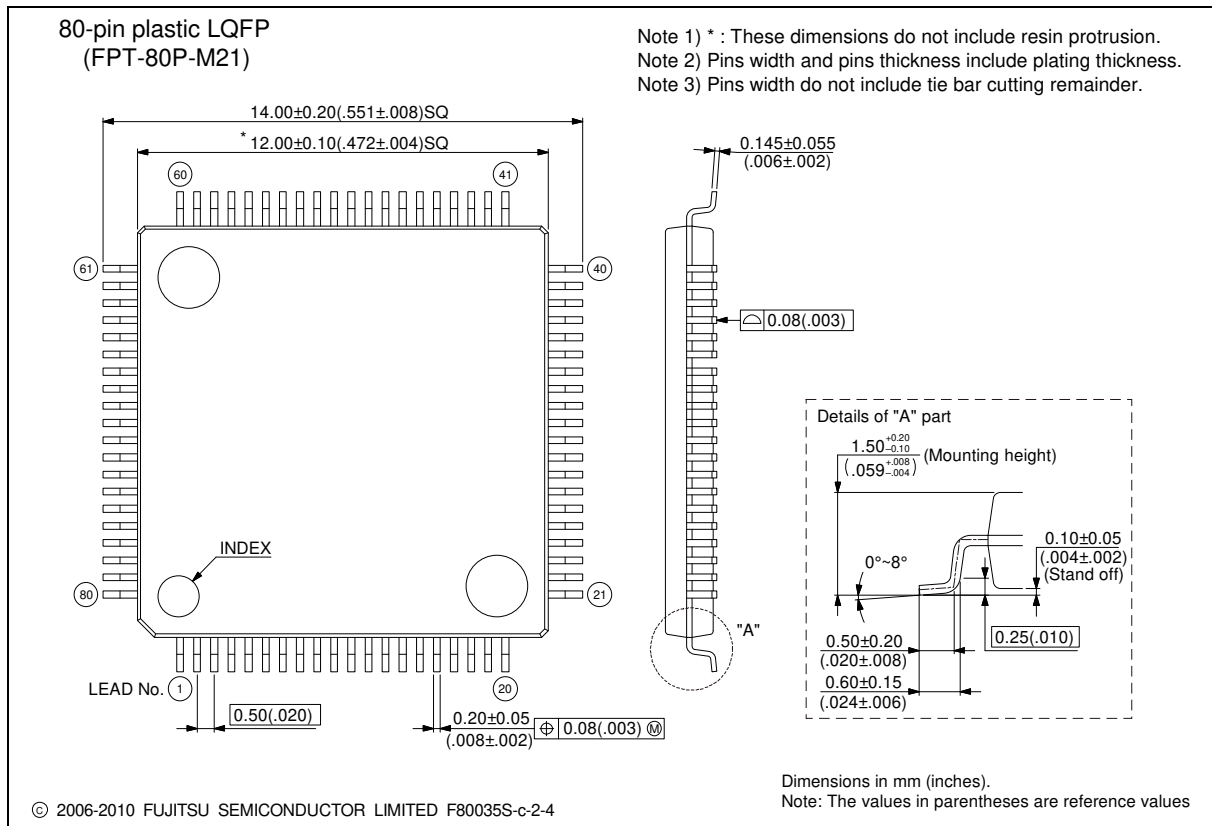

Please check the latest package dimension at the following URL.
<http://edevice.fujitsu.com/package/en-search/>

MB9A310A Series

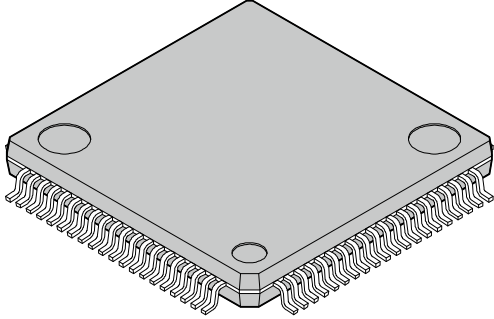
<p>80-pin plastic LQFP</p>  <p>(FPT-80P-M37)</p>	Lead pitch	0.50 mm
	Package width × package length	12.00 mm × 12.00 mm
	Lead shape	Gullwing
	Lead bend direction	Normal bend
	Sealing method	Plastic mold
	Mounting height	1.70 mm MAX
	Weight	0.47 g

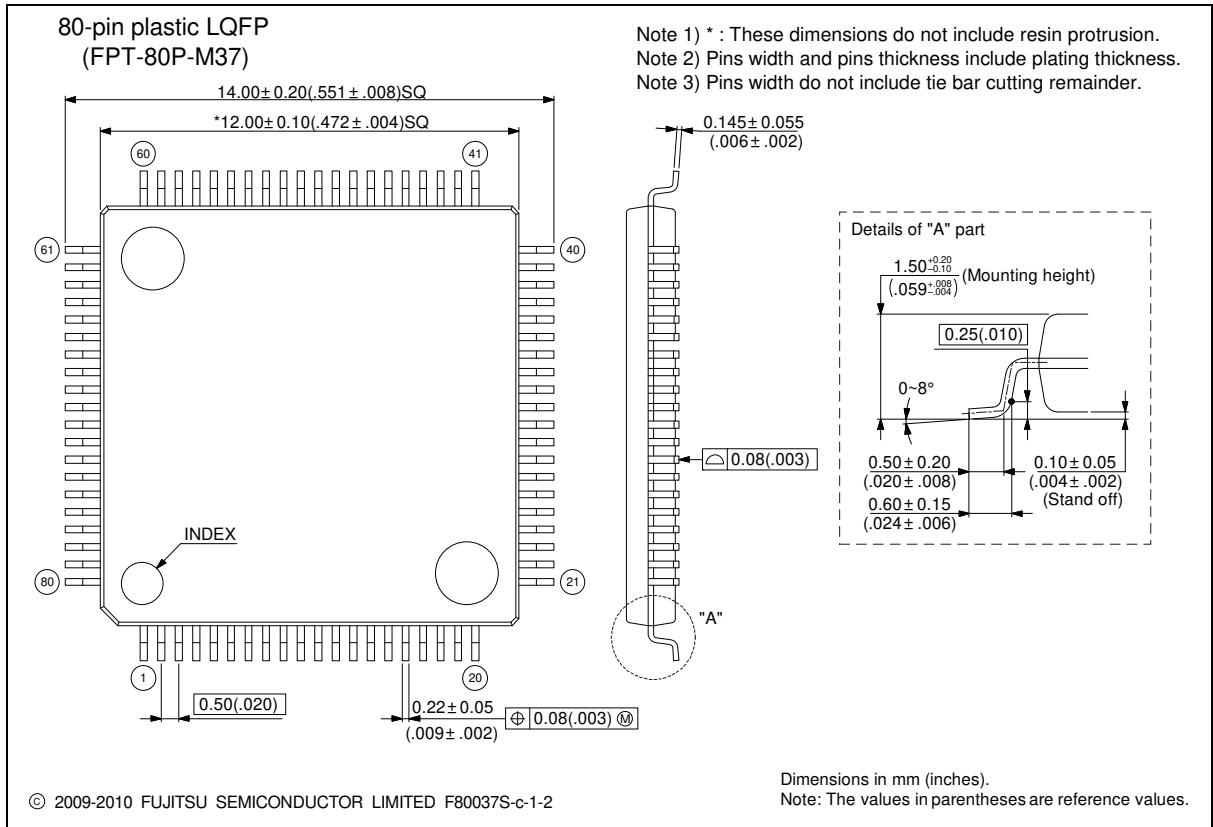

Please check the latest package dimension at the following URL.
<http://edevic.fujitsu.com/package/en-search/>

MB9A310A Series

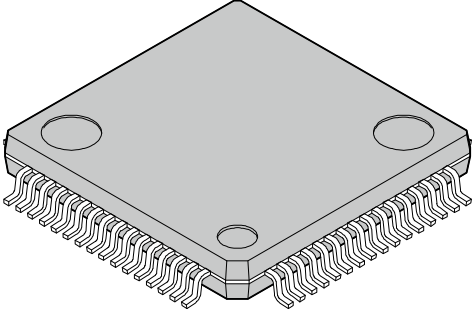
<p>64-pin plastic LQFP</p>  <p>(FPT-64P-M24)</p>	Lead pitch	0.50 mm
	Package width × package length	10.0 × 10.0 mm
	Lead shape	Gullwing
	Sealing method	Plastic mold
	Mounting height	1.70 mm MAX
	Weight	0.32 g
	Code (Reference)	P-LFQFP64-10×10-0.50

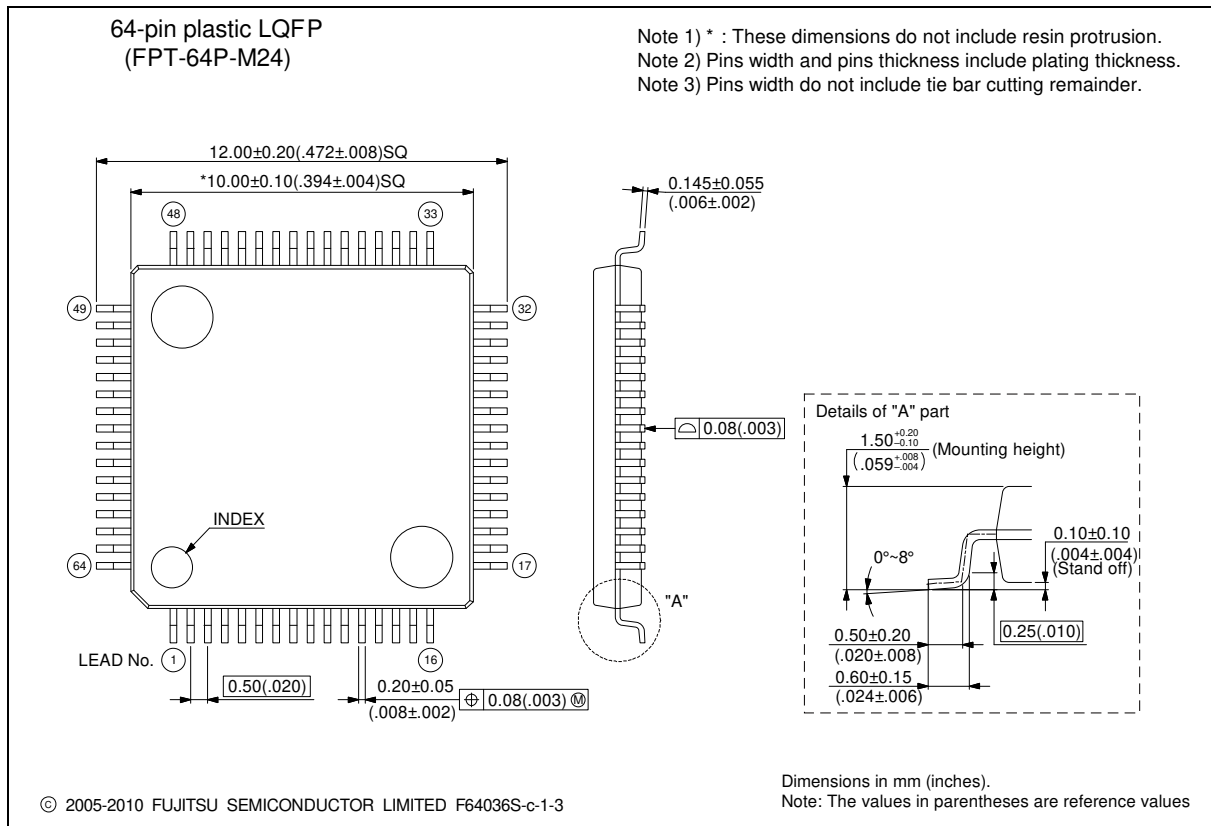

Please check the latest package dimension at the following URL.
<http://edevic.fujitsu.com/package/en-search/>

MB9A310A Series

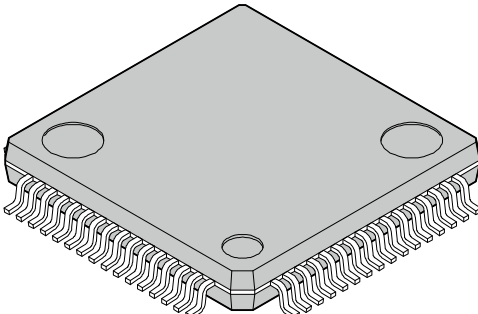
<p>64-pin plastic LQFP</p>  <p>(FPT-64P-M38)</p>	Lead pitch	0.50 mm
	Package width × package length	10.00 mm × 10.00 mm
	Lead shape	Gullwing
	Lead bend direction	Normal bend
	Sealing method	Plastic mold
	Mounting height	1.70 mm MAX
	Weight	0.32 g

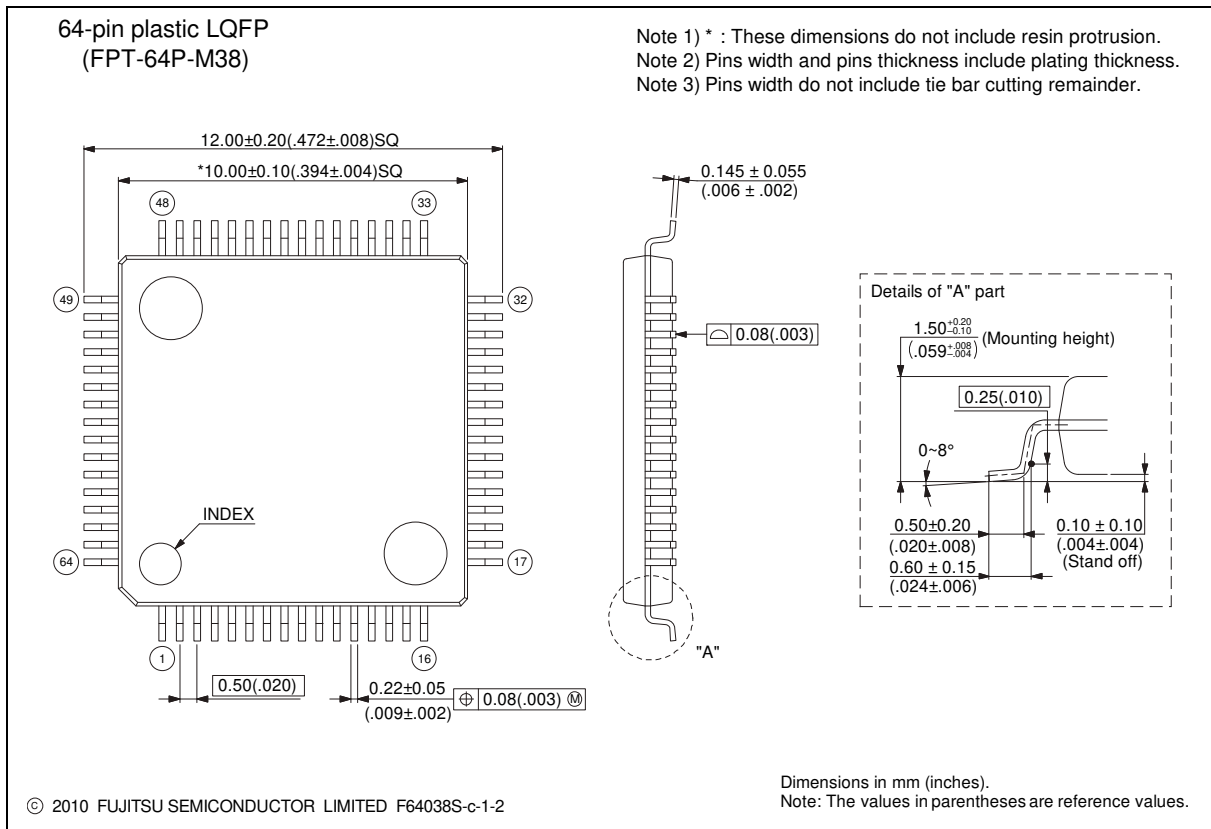

Please check the latest package dimension at the following URL.
<http://edevice.fujitsu.com/package/en-search/>

MB9A310A Series

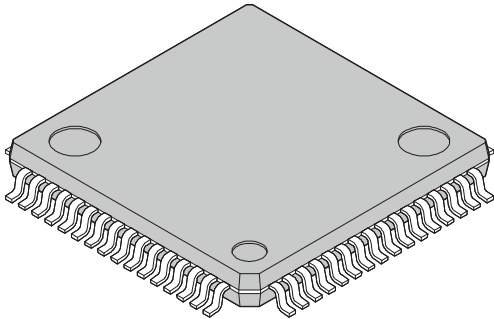
<p>64-pin plastic LQFP</p>  <p>(FPT-64P-M23)</p>	Lead pitch	0.65 mm
	Package width × package length	12.0 × 12.0 mm
	Lead shape	Gullwing
	Sealing method	Plastic mold
	Mounting height	1.70 mm MAX
	Weight	0.47 g
	Code (Reference)	P-LQFP64-12 × 12-0.65

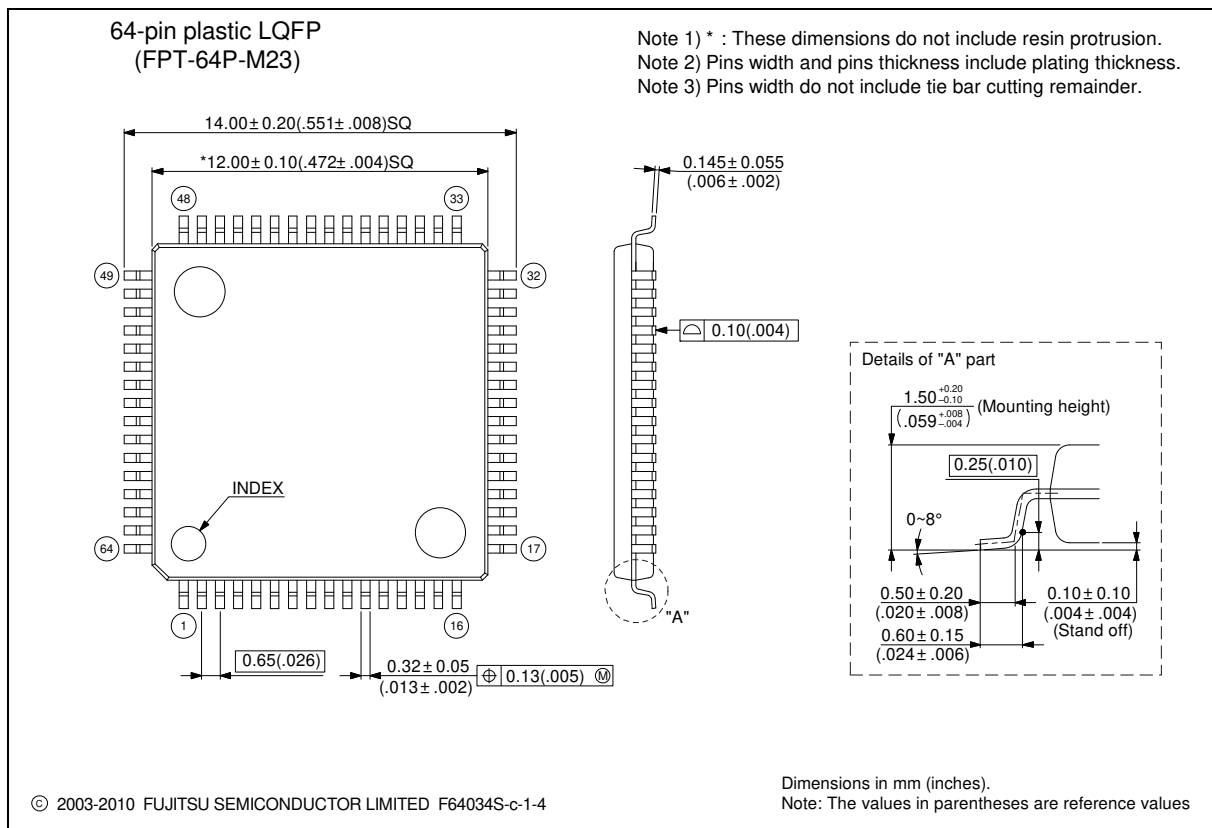

Please check the latest package dimension at the following URL.
<http://edevic.fujitsu.com/package/en-search/>

MB9A310A Series

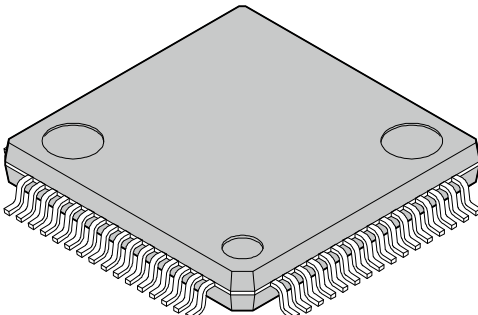
<p>64-pin plastic LQFP</p>  <p>(FPT-64P-M39)</p>	Lead pitch	0.65 mm
	Package width × package length	12.00 mm × 12.00 mm
	Lead shape	Gullwing
	Sealing method	Plastic mold
	Mounting height	1.70 mm MAX
	Weight	0.47 g

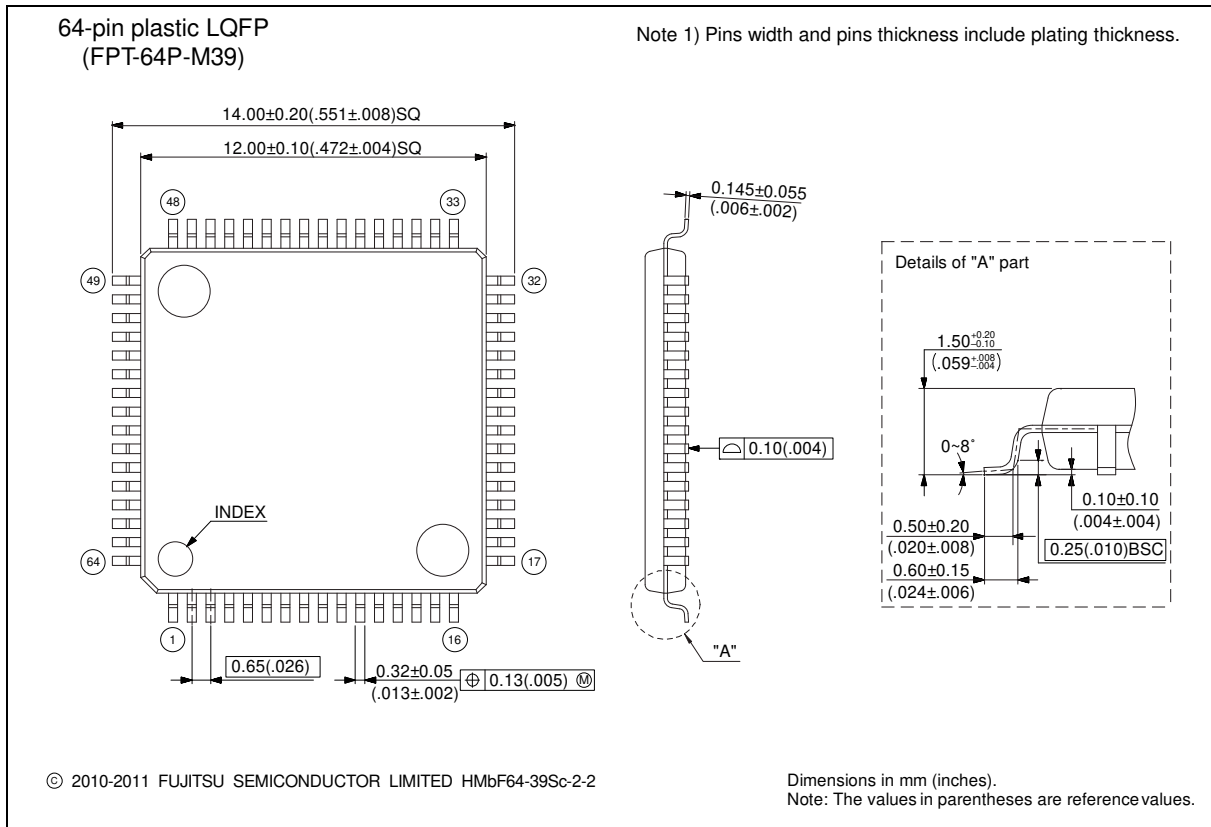

Please check the latest package dimension at the following URL.
<http://edevice.fujitsu.com/package/en-search/>

MB9A310A Series

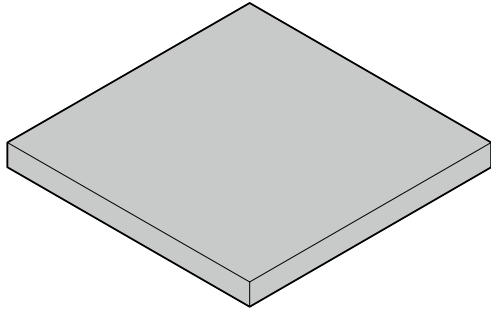
<p>112-ball plastic PFBGA</p>  <p>(BGA-112P-M04)</p>	Ball pitch	0.80 mm
	Package width × package length	10.00 × 10.00 mm
	Lead shape	Soldering ball
	Sealing method	Plastic mold
	Ball size	Φ 0.45 mm
	Mounting height	1.45 mm Max.
	Weight	0.22 g

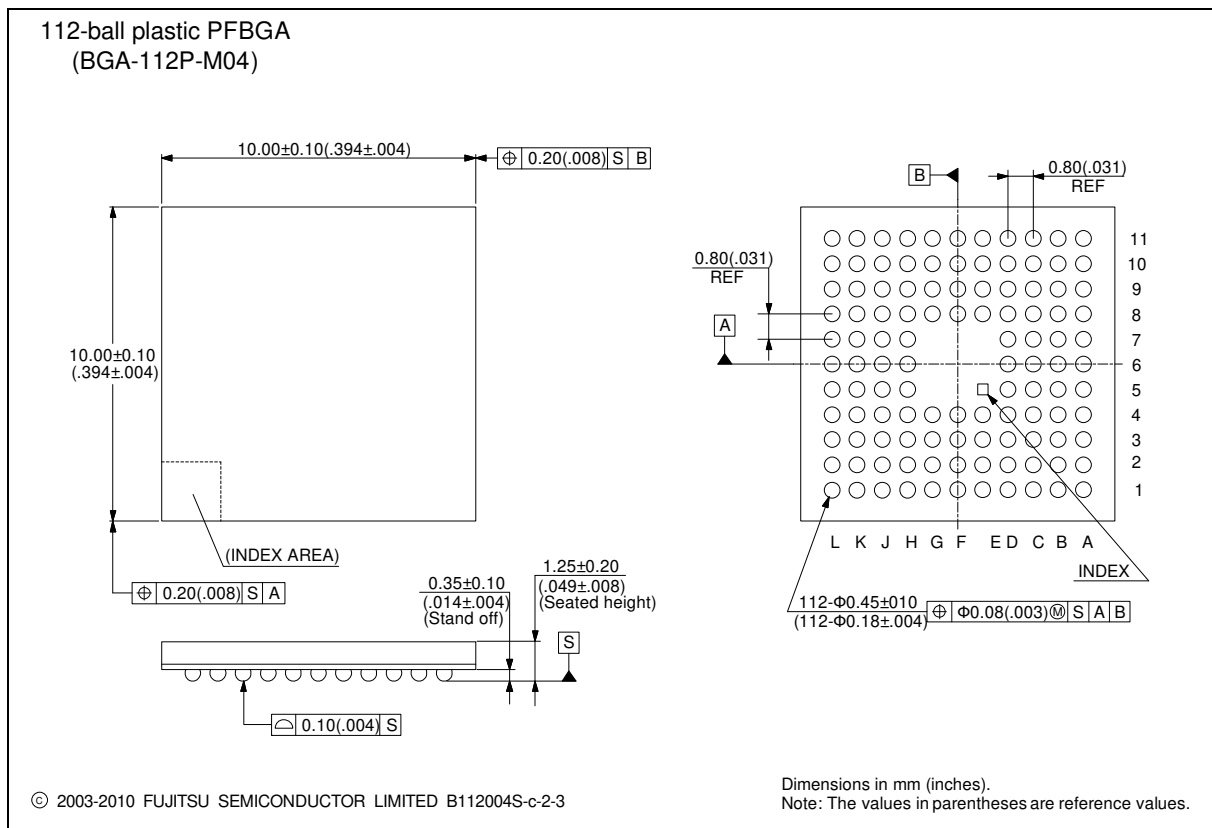

Please check the latest package dimension at the following URL.
<http://edevice.fujitsu.com/package/en-search/>

MB9A310A Series

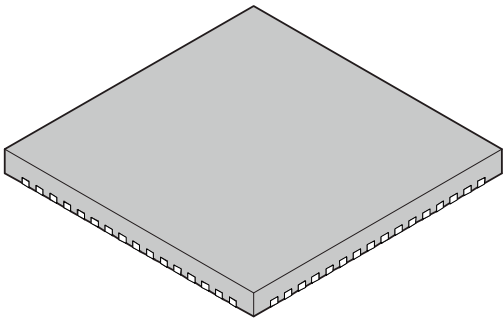
<p>64-pin plastic QFN</p>  <p>(LCC-64P-M24)</p>	Lead pitch	0.50 mm
	Package width × package length	9.00 mm × 9.00 mm
	Sealing method	Plastic mold
	Mounting height	0.90 mm MAX
	Weight	-

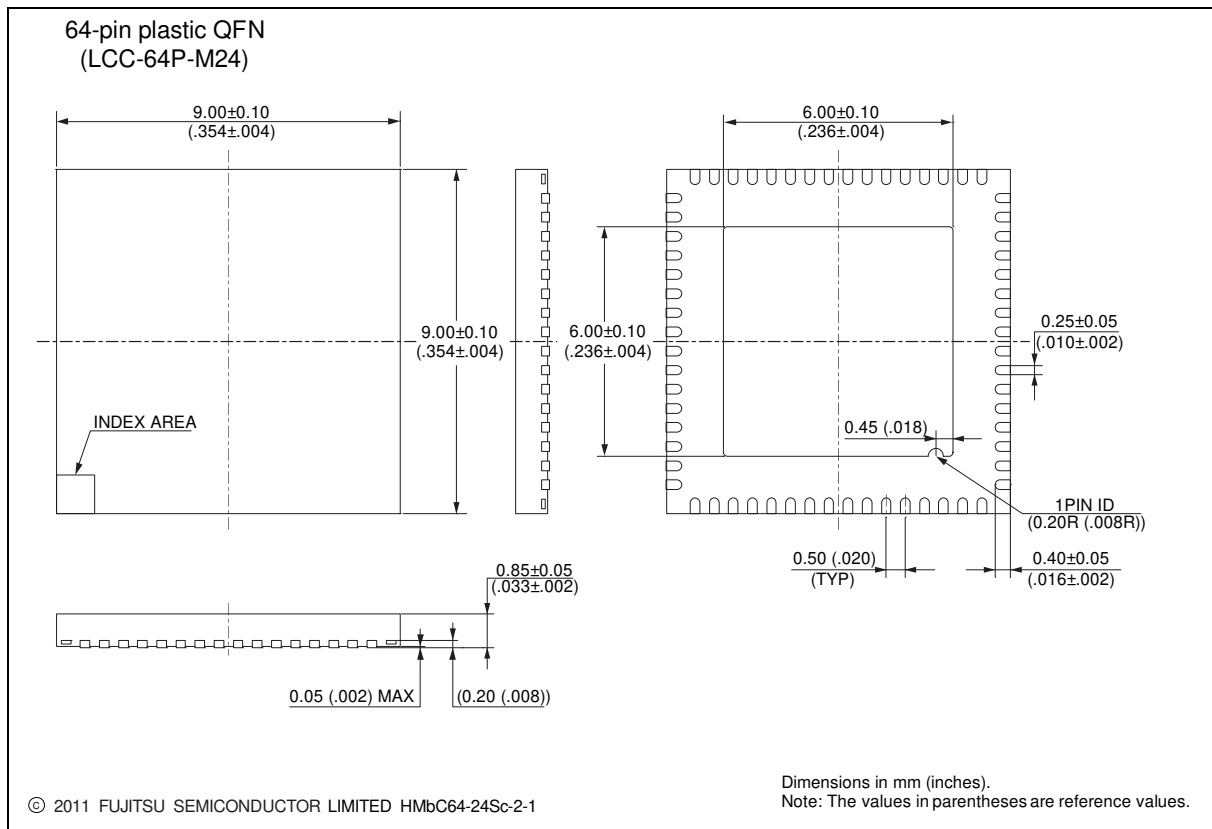

Please check the latest package dimension at the following URL.
<http://edevic.fujitsu.com/package/en-search/>

■ MAJOR CHANGES IN THIS EDITION

A change on a page is indicated by a vertical line drawn on the left side of that page.

Page	Section	Change Results
-	-	<ul style="list-style-type: none"> Revised series name and part number: MB9A310 Series → MB9A310A Series MB9AF311L → MB9AF311LA MB9AF312L → MB9AF312LA MB9AF314L → MB9AF314LA MB9AF311M → MB9AF311MA MB9AF312M → MB9AF312MA MB9AF314M → MB9AF314MA MB9AF315M → MB9AF315MA MB9AF316M → MB9AF316MA MB9AF311N → MB9AF311NA MB9AF312N → MB9AF312NA MB9AF314N → MB9AF314NA MB9AF315N → MB9AF315NA MB9AF316N → MB9AF316NA Added the following package. LCC-64P-M24
7	■PRODUCT LINEUP Function Multi-function Serial	Added the following description. ch.4 to ch.7: FIFO (16steps × 9-bit) ch.0 to ch.3: No FIFO
	External Interrupts	Corrected the following description. 7pins (Max) → 8pins (Max)
34 to 37	■SIGNAL DESCRIPTION Multi-function Serial (ch.0 to ch.7)	Corrected the description for function. <ul style="list-style-type: none"> Added "LIN pin" Deleted "UART pin"
42, 43	■I/O CIRCUIT TYPE	<ul style="list-style-type: none"> Corrected the following schematic for "TypeB". CMOS level hysteresis input → Digital input Corrected the following schematic for "TypeC". Control Pin → Digital output
51	■HANDLING DEVICE <ul style="list-style-type: none"> Power supply pins 	Corrected the description.
54	■MEMORY SIZE	Added " ■MEMORY SIZE ".
69	■ELECTRICAL CHARACTERISTICS 4. AC Characteristics (1)Main Clock input Characteristics	Added the items F_{CM} to the Internal operating clock frequency.
71	(4-2) Operating Conditions of Main PLL	Added the description.
72	(7) External Bus Timing <ul style="list-style-type: none"> External bus clock output Characteristics 	
79	(8) Base Timer Input Timing <ul style="list-style-type: none"> Trigger input timing 	Added the Note.
88	(10) External input timing	Corrected the footnote.

MB9A310A Series

Page	Section	Change Results
94	5. 12-bit A/D Converter (1) Electrical characteristics for the A/D converter	<ul style="list-style-type: none">• Corrected the value of "Full-scale transition voltage". Min: -20 → AVRH-20 Max: +20 → AVRH+20• Corrected the value of "Compare clock cycle". Max: 10000 → 2000• Corrected the value of "Reference voltage". Min: AVSS → 2.7

MEMO

MEMO

MEMO

MB9A310A Series

FUJITSU SEMICONDUCTOR LIMITED

Nomura Fudosan Shin-yokohama Bldg. 10-23, Shin-yokohama 2-Chome,
Kohoku-ku Yokohama Kanagawa 222-0033, Japan

Tel: +81-45-415-5858

<http://jp.fujitsu.com/fsl/en/>

For further information please contact:

North and South America

FUJITSU SEMICONDUCTOR AMERICA, INC.

1250 E. Arques Avenue, M/S 333

Sunnyvale, CA 94085-5401, U.S.A.

Tel: +1-408-737-5600 Fax: +1-408-737-5999

<http://us.fujitsu.com/micro/>

Asia Pacific

FUJITSU SEMICONDUCTOR ASIA PTE. LTD.

151 Lorong Chuan,

#05-08 New Tech Park 556741 Singapore

Tel : +65-6281-0770 Fax : +65-6281-0220

<http://sg.fujitsu.com/semiconductor/>

Europe

FUJITSU SEMICONDUCTOR EUROPE GmbH

Pittlerstrasse 47, 63225 Langen, Germany

Tel: +49-6103-690-0 Fax: +49-6103-690-122

<http://emea.fujitsu.com/semiconductor/>

FUJITSU SEMICONDUCTOR SHANGHAI CO., LTD.

30F, Kerry Parkside, 1155 Fang Dian Road,

Pudong District, Shanghai 201204, China

Tel : +86-21-6146-3688 Fax : +86-21-6146-3660

<http://cn.fujitsu.com/fss/>

Korea

FUJITSU SEMICONDUCTOR KOREA LTD.

902 Kosmo Tower Building, 1002 Daechi-Dong,

Gangnam-Gu, Seoul 135-280, Republic of Korea

Tel: +82-2-3484-7100 Fax: +82-2-3484-7111

<http://kr.fujitsu.com/fsk/>

FUJITSU SEMICONDUCTOR PACIFIC ASIA LTD.

10/F., World Commerce Centre, 11 Canton Road,

Tsimshatsui, Kowloon, Hong Kong

Tel : +852-2377-0226 Fax : +852-2376-3269

<http://cn.fujitsu.com/fsp/>

Specifications are subject to change without notice. For further information please contact each office.

All Rights Reserved.

The contents of this document are subject to change without notice.

Customers are advised to consult with sales representatives before ordering.

The information, such as descriptions of function and application circuit examples, in this document are presented solely for the purpose of reference to show examples of operations and uses of FUJITSU SEMICONDUCTOR device; FUJITSU SEMICONDUCTOR does not warrant proper operation of the device with respect to use based on such information. When you develop equipment incorporating the device based on such information, you must assume any responsibility arising out of such use of the information.

FUJITSU SEMICONDUCTOR assumes no liability for any damages whatsoever arising out of the use of the information.

Any information in this document, including descriptions of function and schematic diagrams, shall not be construed as license of the use or exercise of any intellectual property right, such as patent right or copyright, or any other right of FUJITSU SEMICONDUCTOR or any third party or does FUJITSU SEMICONDUCTOR warrant non-infringement of any third-party's intellectual property right or other right by using such information. FUJITSU SEMICONDUCTOR assumes no liability for any infringement of the intellectual property rights or other rights of third parties which would result from the use of information contained herein.

The products described in this document are designed, developed and manufactured as contemplated for general use, including without limitation, ordinary industrial use, general office use, personal use, and household use, but are not designed, developed and manufactured as contemplated (1) for use accompanying fatal risks or dangers that, unless extremely high safety is secured, could have a serious effect to the public, and could lead directly to death, personal injury, severe physical damage or other loss (i.e., nuclear reaction control in nuclear facility, aircraft flight control, air traffic control, mass transport control, medical life support system, missile launch control in weapon system), or (2) for use requiring extremely high reliability (i.e., submersible repeater and artificial satellite).

Please note that FUJITSU SEMICONDUCTOR will not be liable against you and/or any third party for any claims or damages arising in connection with above-mentioned uses of the products.

Any semiconductor devices have an inherent chance of failure. You must protect against injury, damage or loss from such failures by incorporating safety design measures into your facility and equipment such as redundancy, fire protection, and prevention of over-current levels and other abnormal operating conditions.

Exportation/release of any products described in this document may require necessary procedures in accordance with the regulations of the Foreign Exchange and Foreign Trade Control Law of Japan and/or US export control laws.

The company names and brand names herein are the trademarks or registered trademarks of their respective owners.