

© - TE Connectivity. All Rights Reserved.

REVISIONS				
P	LTR	DESCRIPTION	DATE	APVD
	A1	REVISED PER ECR-21-103794	03JUN2021	RS WK

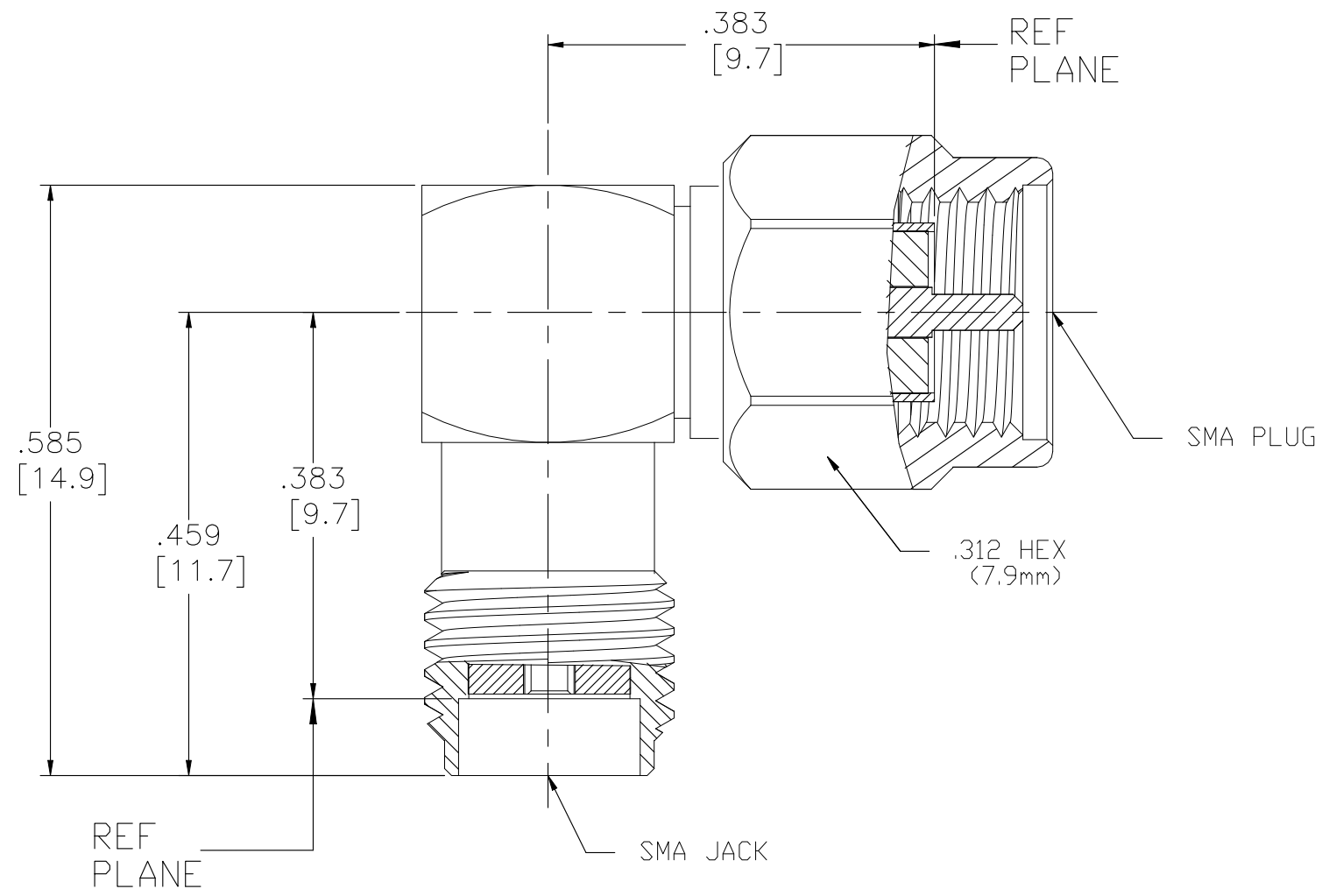

ELECTRICAL	MECHANICAL	ENVIRONMENTAL
Nominal Impedance (Ohms) 50	Interface Dimensions MIL-STD-348A, Fig. 310.1,2	Temperature Rating -65°C to +125°C
Frequency Range (GHz) DC to 18	Recommended Mating Torque 7 to 10	Vibration MIL-STD-202, Method 204, Condition D
Volt Rating (VRMS MAX) @ Sea Level 335	Mating Characteristics: Insertion (MAX Lbs) 3	Shock MIL-STD-202, Method 213, Condition I
VSWR 1.15 + .015(f/GHz)	Withdrawal (MIN Oz) 1	Thermal Shock MIL-STD-202, Method 107, Condition B, Except High Temp
Insertion Loss (dB MAX) .06√f(GHz)	Force to Engage and Disengage (In-Lbs MAX) 2	Moisture Resistance MIL-STD-202, Method 106
RF Leakage (dB MIN) -(90-f(GHz))	Center Contact Captivation Axial (Lbs) 6	Corrosion - MIL-STD-202, Method 101, Condition B, 5% salt spray
Corona, 70,000 Ft (VRMS MIN) 250	Cable Retention Axial Force (Lbs) N/A	
Dielectric Withstanding Voltage (VRMS MIN) @ Sea Level 1000	Torque (In-Oz) N/A	
Contact Resistance (Milliohms MAX) Center Contact 2	Weight (Grams) TBD	
Outer Contact 2		
Cable to Housing N/A		
RF High Potential @ Sea Level (VRMS MIN @ 5 MHz) 670		
I.R.(Megohms MIN) 10,000		

.XXX = in
XX.X = mm

THIS DRAWING IS A CONTROLLED DOCUMENT.

DIMENSIONS:	TOLERANCES UNLESS OTHERWISE SPECIFIED:
INCHES	
	0 PLC ± -
	1 PLC ± -
	2 PLC ± -
	3 PLC ± .005
	4 PLC ± -
	ANGLES ± 1
MATERIAL	FINISH
-	± 1/64

QUANTITY PER ASSY	PARTS LIST
1	PASSIVATE STAINLESS STEEL CAP 7
1	- SILICONE RUBBER GASKET 6
1	- BeCu RETAINING RING 5
1	PASSIVATE STAINLESS STEEL COUPLING NUT 4
1	PASSIVATE STAINLESS STEEL HOUSING 3
1	- PTFE INSULATION 2
1	Au BeCu CENTER CONTACT 1
-1	PLATING MATERIAL DESCRIPTION ITEM

STE TE Connectivity

SMA RIGHT ANGLE PLUG TO JACK ADAPTER (MA-COM 2088-0000-02)

DWN BB 11/09/73	NAME	SIZE	CAGE CODE	DRAWING NO	RESTRICTED TO
CHK CW 10/05/89		A3	00779	C-1055065	-
APVD NGB 10/05/89					
PRODUCT SPEC					
APPLICATION SPEC					
WEIGHT -					

CUSTOMER DRAWING SCALE 6:1 SHEET 1 OF 1 REV A1