

THIS DRAWING CONTAINS INFORMATION THAT IS PROPRIETARY TO J.S.T. AND SHALL NOT BE USED OR SHOWN WITHOUT WRITTEN PERMISSION.

4		3	2		1												
ITEM	CONNECTOR PART NO.	DESCRIPTION	IPI CHECK	EOR CHECK	Applicable Tooling												
1	RSFP-LP-1V-R-250-K	RSF CONNECTOR BLACK HOUSING, W-W			APPLICATOR SUGGESTED MATING TAB NO SCALE <table border="1"> <thead> <tr> <th></th> <th>WITHOUT STABILIZER</th> <th>WITH STABILIZER</th> </tr> </thead> <tbody> <tr> <td>DIM. "A"</td> <td>2.20 [0.087] MIN.</td> <td>4.20±0.15 [0.165±0.006]</td> </tr> <tr> <td>DIM. "B"</td> <td>7.40 [0.291] MIN.</td> <td>7.98 [0.314] MIN.</td> </tr> <tr> <td>DIM. "C"</td> <td>5.90 [0.232] MAX.</td> <td>(7.6)</td> </tr> </tbody> </table>		WITHOUT STABILIZER	WITH STABILIZER	DIM. "A"	2.20 [0.087] MIN.	4.20±0.15 [0.165±0.006]	DIM. "B"	7.40 [0.291] MIN.	7.98 [0.314] MIN.	DIM. "C"	5.90 [0.232] MAX.	(7.6)
	WITHOUT STABILIZER	WITH STABILIZER															
DIM. "A"	2.20 [0.087] MIN.	4.20±0.15 [0.165±0.006]															
DIM. "B"	7.40 [0.291] MIN.	7.98 [0.314] MIN.															
DIM. "C"	5.90 [0.232] MAX.	(7.6)															
2	SRSF-61-250A	RSF CONTACT - BRASS															
3	UL1015, 16 AWG	BLACK															

	WITHOUT STABILIZER	WITH STABILIZER
DIM. "A"	2.20 [0.087] MIN.	4.20±0.15 [0.165±0.006]
DIM. "B"	7.40 [0.291] MIN.	7.98 [0.314] MIN.
DIM. "C"	5.90 [0.232] MAX.	(7.6)

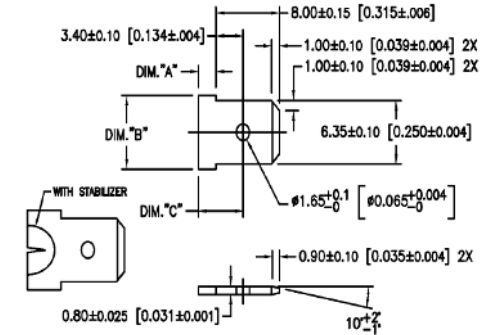

MATING TAB NOTES:
 4. MAT'L: BRASS.
 FINISH: SUGGESTED NO PLATING.

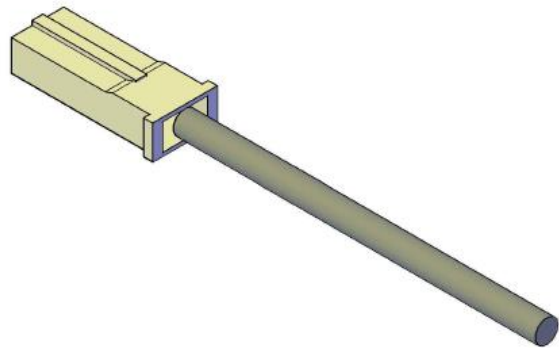
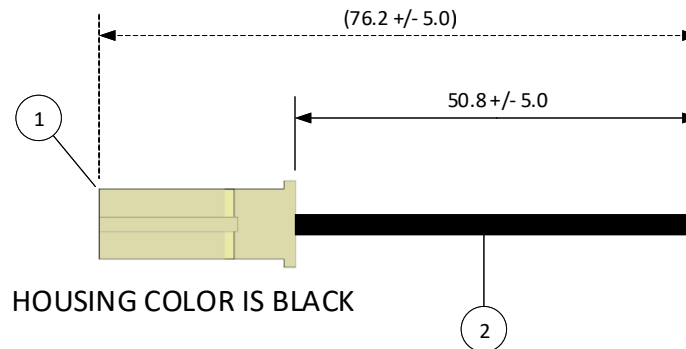

SCALE	CUSTOMER NAME	CUSTOMER PART NO.
1: 1		
DIMENSIONS All dimensions are in MM with a tolerance of +/- 3.0 unless otherwise specified.	DESCRIPTION 2" INSIDE LENGTH - 1 POSITION, LIF, POS LOCK, .250, W-W INSULATED PLUG W/BLUNT LEADS, BLACK HSG MATES W/W-W RECPT 01RSFR16K51K	
DRAWN BY STEVEN PILKINGTON	ASSEMBLY PART NO. A01RSFP16K51K	
CHECKED BY JUSTIN BAKER	DRAWING NO. & REVISION GAM-112	REVISED 3/11/2016

REV.	DESCRIPTION	DATE	BY

4 | 3 | 2 | 1