

LC Sine Wave Filter for Motor Drives

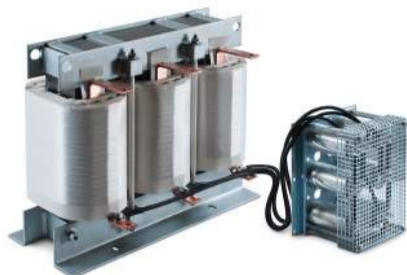

- Smooth sine wave without voltage peaks
- Perfect motor protection
- Reduce bearing currents
- Motor frequency up to 200 Hz
- Extended motor cable length capability



Performance indicators

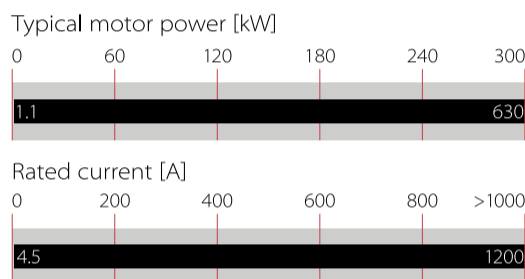

Approvals & Compliances



UL 61800-5-1 up to 750 A for FN 5040, 480 A for FN 5045. For use with AC or DC drives (power conversion equipment) only

Features and Benefits

- Converts the rectangular PWM output voltage of motor drives into a smooth sine wave with low residual ripple
- Elimination of premature motor damage caused by high dv/dt, overvoltages, cable ringing, motor overheating, and eddy current losses
- Improves bearing life time because of bearing currents caused by circulating currents
- Complies with IEC 60034-17* and NEMA-MG1 requirements for general purpose motors
- Optional with NEMA 1 protective cover

Technical Specifications

Nominal operating voltage	3x480 VAC
Rated operating voltage	3x525 VAC
Motor frequency	0...70 Hz (up to 200Hz with derating (see graph))
Switching frequency	See filter selection table
Rated currents	4.5 to 1200 A @ 45°C
Motor cable length	Up to 2,000 m (see graph)
Impedance (uk)	8 to 10% @ 400 V, 50 Hz and rated current
Residual ripple voltage	<5%
High potential test voltage	P → E 3000 VAC, 1 minute P → P 2500 VAC, 1 minute
Protection category	IP 00 (FN 5040) IP 20 (FN 5045)
Overload capability	1.5x rated current for 1 minute, once per hour
Ambient temperature range	-25°C to +45°C fully operation +45°C to 70°C derated operation* -25°C to +85°C transport and storage
Insulation class	EIS 200
Flammability corresponding to	UL 94 V-2
Design corresponding to	Chokes: EN 61558-2-20 or EN 60076-6 Filter: UL 61800-5-1, EN 61800-5-1
MTBF	>100,000 hours
Rated currents	4.5 to 1200 A @50°C (480 V filters)

Typical Applications

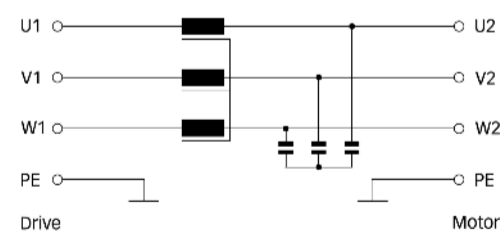

- HVAC applications
- Pumps
- Ventilators
- Conveyors
- Compressors
- Elevators
- Cranes
- Medium voltage applications, deployed in front of the step-up transformer
- Retrofit installations with motor drives
- Motor drive with long motor cable
- Motor drive with multiple motors in parallel

Typical electrical schematic



* Iderated = $Inominal \cdot \sqrt{\frac{(Tmax-Tamb)}{(Tmax-Tnominal)}}$ = $Inom \cdot \sqrt{\frac{(70°C-Tamb)}{25°C}}$

Filter Selection Table

Filter	Rated current @ 45°C/ 50Hz	Rated current @ 45°C/ 100Hz	Typical motor drive power rating @ 400 V*	Typical motor drive power rating @ 480 V**	Nominal inductance	Nominal capacitance	Capacitance connection	Min. switching frequency	Typical power loss***	Input/Output connections		Weight [kg]
	[A]	[A]	[kW]	[kW]	[mH]	[μF]		[kHz]	[W]			
FN 5040-4.5-82	4.5	4.05	1.1/1.5	1.3/1.8	13	2.2	Y	4	65	-82		3.3
FN 5040-8-82	8	7.2	2.2/3	2.64/3.6	6.9	4.7	Y	4	80	-82		4.6
FN 5040-10-83	10	9	4	4.8	5.2	6.8	Y	4	90	-83		6.1
FN 5040-17-83	17	15.3	5.5/7.5	6.6/9.0	3.1	10	Y	4	115	-83		7.8
FN 5040-24-84	24	21.6	11	13.2	2.4	10	Y	4	150	-84		14.4
FN 5040-38-84	38	34.2	15/18.5	18/22.2	1.6	10	Y	4	170	-84		25.0
FN 5040-48-85	48	43.2	22	26.4	1.1	14.7	Y	4	260	-85		33.0
FN 5040-62-86	62	55.8	30	36	0.85	30	Y	3	280	-86		36.0
FN 5040-75-87	75	67.5	37	44.4	0.75	30	Y	3	330	-87		42.0
FN 5040-115-87	115	103.5	45/55	52.8/66	0.5	20	Δ	3	500	-87		68.0
FN 5040-180-99	180	162	75/90	90/108	0.3	33	Δ	3	680	-99		86.0
FN 5040-260-99	260	234	110/132	132/158.4	0.2	47	Δ	3	880	-99		125.0
FN 5040-410-99	410	369	160/200	192/240	0.13	66	Δ	3	1100	-99		184.0
FN 5040-480-99	480	432	250	300	0.11	94	Δ	3	1350	-99		235.0
FN 5040-660-99	660	594	315/355	378/426	0.14	141	Δ	2	2000	-99		310.0
FN 5040-750-99	750	675	400	480	0.12	165	Δ	2	2800	-99		470.0
FN 5040-880-99	880	792	400/500	480/600	0.11	188	Δ	2	3400	-99		640.0
FN 5040-1200-99	1200	1080	560/630	672/756	0.075	282	Δ	2	3800	-99		680.0
FN 5045-4.5-44	4.5	4.05	1.1/1.5	1.3/1.8	13	2.2	Y	4	65	-44		4.1
FN 5045-8-44	8	7.2	2.2/3	2.64/3.6	6.9	4.7	Y	4	80	-44		5.4
FN 5045-10-44	10	9	4	4.8	5.2	6.8	Y	4	90	-44		6.9
FN 5045-17-33	17	15.3	5.5/7.5	6.6/9.0	3.1	10	Y	4	115	-33		9.0
FN 5045-24-33	24	21.6	11	13.2	2.4	10	Y	4	150	-33		15.6
FN 5045-38-33	38	34.2	15/18.5	18/22.2	1.6	10	Y	4	170	-33		18.9
FN 5045-48-34	48	43.2	22	26.4	1.1	14.7	Y	4	260	-34		35.8
FN 5045-62-34	62	55.8	30	36	0.85	30	Y	3	280	-34		37.8
FN 5045-75-35	75	67.5	37	44.4	0.75	30	Y	3	330	-35		60.0
FN 5045-115-35	115	103.5	45/55	52.8/66	0.5	20	Δ	3	500	-35		70.0
FN 5045-180-99	180	162	75/90	90/108	0.3	33	Δ	3	680	-99		92.0
FN 5045-260-99	260	234	110/132	132/158.4	0.2	47	Δ	3	880	-99		131.0
FN 5045-410-99	410	369	160/200	192/240	0.13	66	Δ	3	1100	-99		198.0
FN 5045-480-99	480	432	250	300	0.11	94	Δ	3	1350	-99		243.0
FN 5045-660-99	660	594	315/355	378/426	0.14	141	Δ	2	2000	-99		425.0
FN 5045-750-99	750	675	400	480	0.12	165	Δ	2	2800	-99		482.0
FN 5045-880-99	880	792	400/500	480/600	0.11	188	Δ	2	3400	-99		652.0
FN 5045-1200-99	1200	1080	560/630	672/756	0.075	282	Δ	2	3800	-99		692.0

* General purpose four-pole (1500 r/min) AC induction motor rated 400 V/50 Hz.

** General purpose four-pole (1500 r/min) AC induction motor rated 480 V/50 Hz.

*** Exact value depends on the motor cable length and type, switching frequency and further stray parameters of the system.

Required Drive Settings

Ensure the drive's switching frequency is set to the required minimum switching frequency (see filter selection table). The mode of operation must be "scalar" (V/Hz) with a fixed switching frequency. Check the drives manufacturer manual whether special settings are necessary. In any doubt contact the drives manufacturer. CAUTION: If the motor drives settings are not correct the filter may be damaged.

Typical Block Schematic

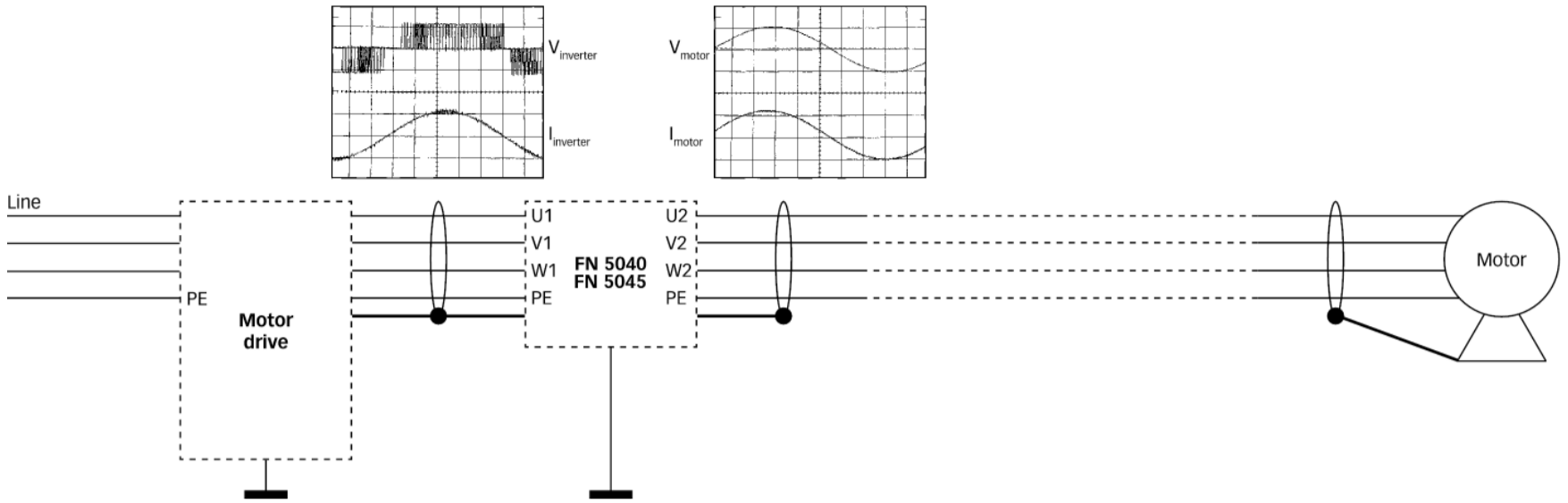

Motor Frequency Derating

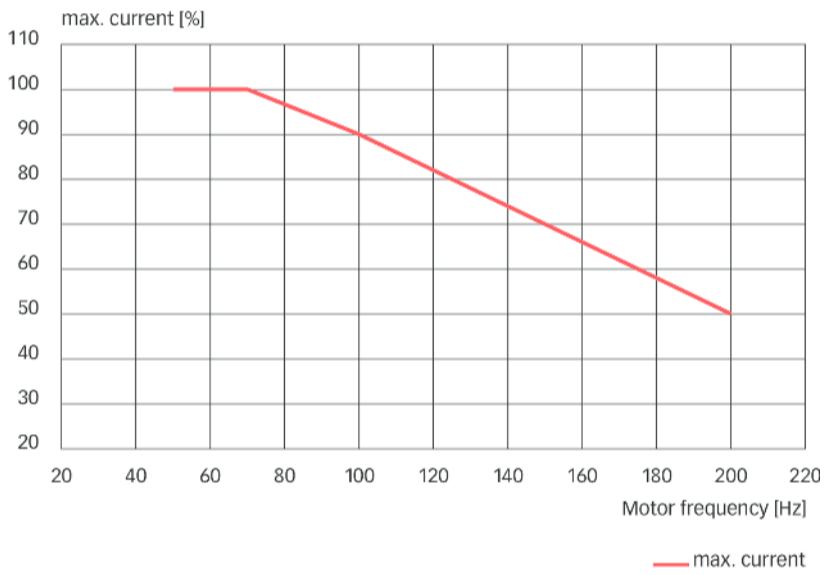

Max. Motor Cable Length

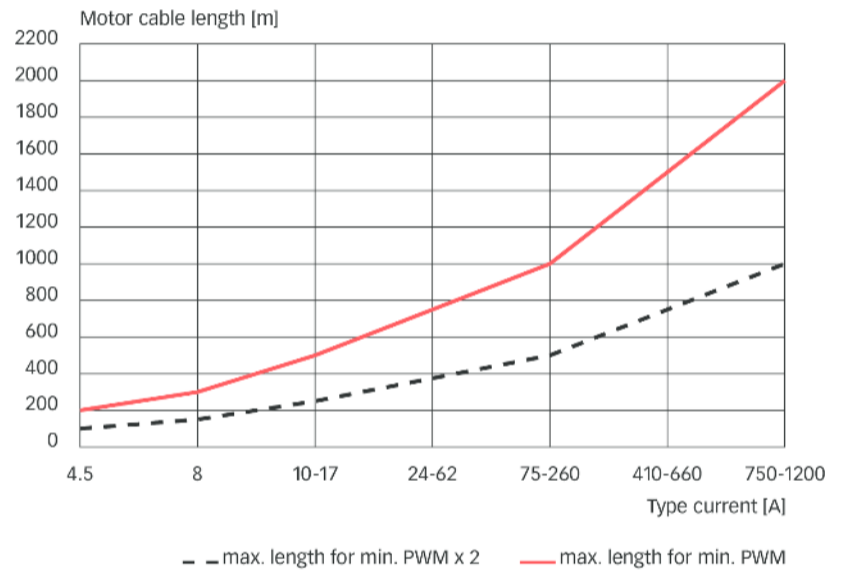

Mechanical Data FN 5040

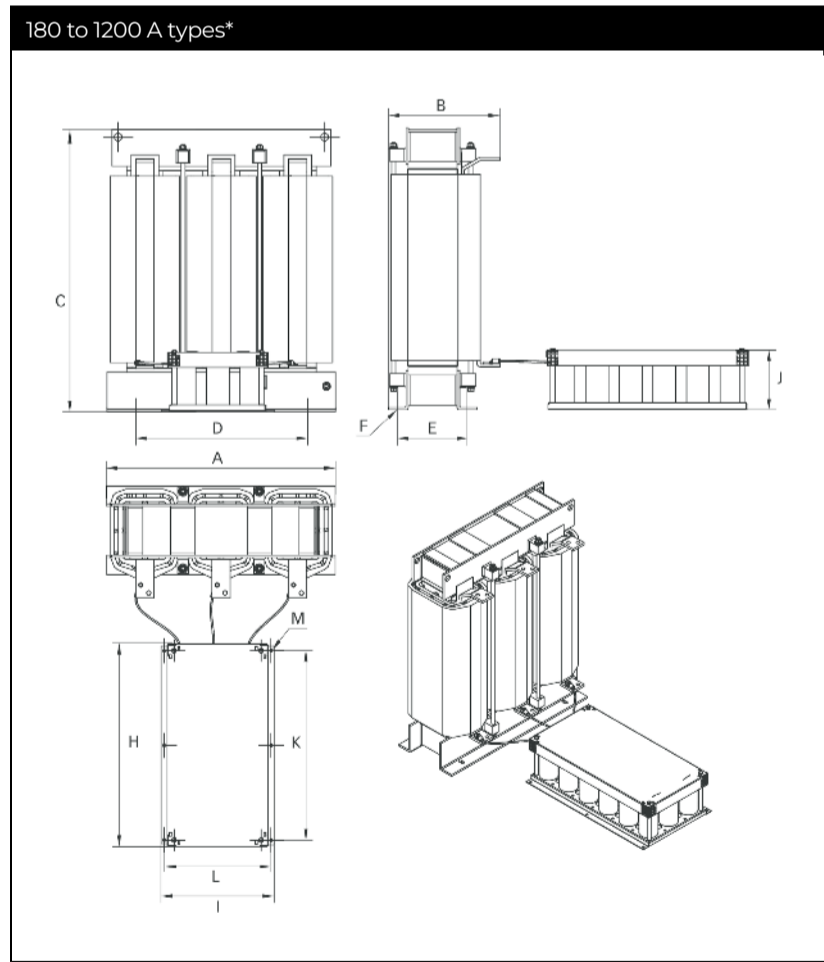
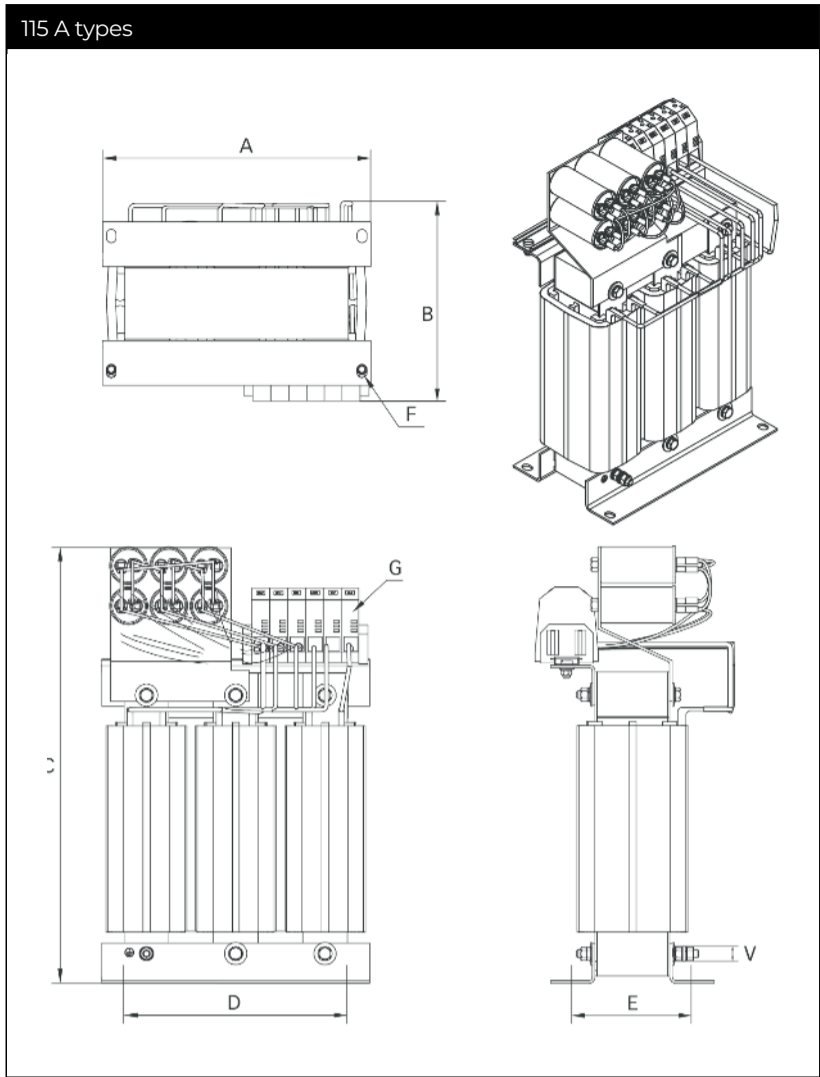
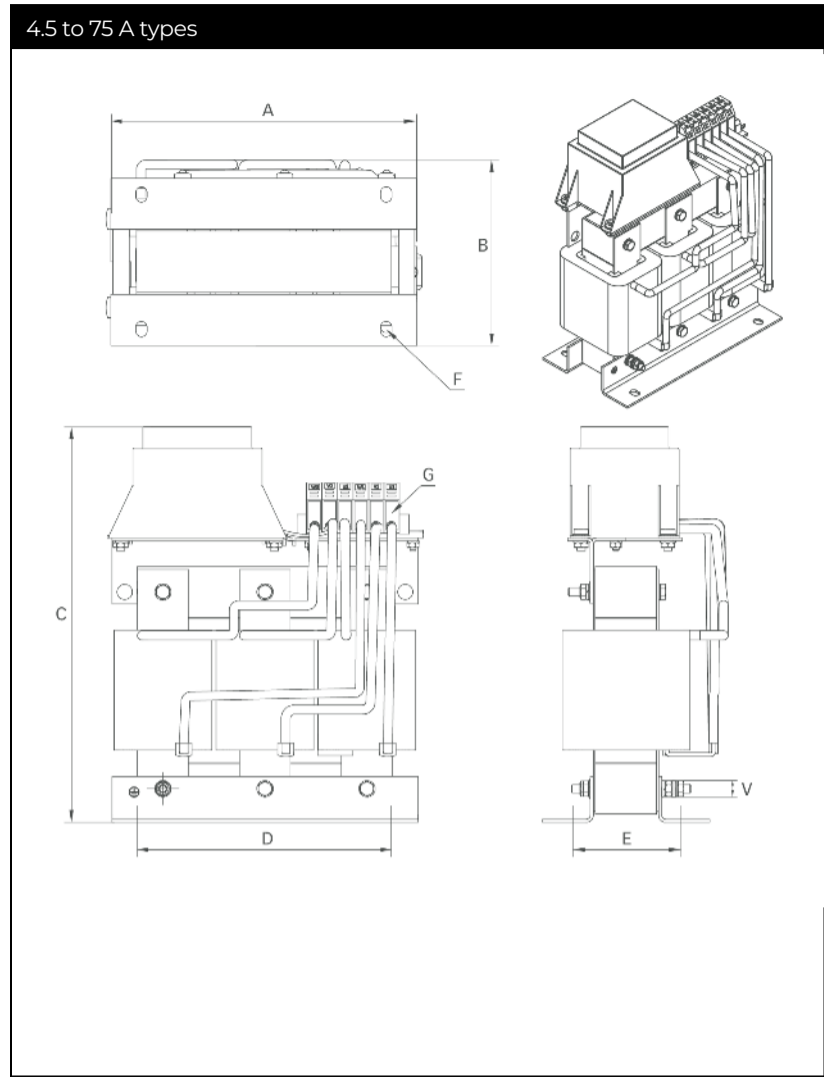

Cable length of capacitor box:
 180 to 410 A = 1000 mm
 480 A to 1200 A = 1500 mm

Dimensions FN 5040

	4.5 A	8 A	10 A	17 A	24 A	38 A	48 A	62 A	75 A	115 A
A	125	155	155	190	190	230	300	320	305	305
B	77	84	94	115	116	151	171	190	240	236
C	171	212	208	224	224	275	355	395	395	495
D	100	130	123	170	170	180	240	240	240	280
E	55	56	71.5	57.5	77.5	122	137	132	162	151
F	5x8	8x12	8x12	8x12	8x12	8x12	11x15	11x15	11x15	11x15
G	2.5 mm ²	2.5 mm ²	4 mm ²	4 mm ²	10 mm ²	10 mm ²	16 mm ²	35 mm ²	50 mm ²	50 mm ²
V	M3	M4	M4	M6	M6	M8	M8	M8	M8	M8

	180 A	260 A	410 A	480 A	660 A	750 A	880 A	1200 A
A	450	453	490	510	645	665	660	750
B	260	255	355	355	410	468	450	375
C	385	485	600	618	732	670	885	925
D	400	370	430	430	570	570	570	570
E	130	150	194	195	210	220	220	220
F	9x13	11x15	10.5x18.5	13x27	13x27	13x26	13x26	13x26
H	328	328	328	328	463	555	463	665
I	170	170	170	270	370	375	370	375
J	200	220	240	220	220	200	220	220
K	300 (150)	300 (150)	300 (150)	300 (150)	400 (200)	510 (255)		620 (310)
L	150	150	150	250	350	350	350	350
M	9	9	9	9	9	9	9	9
V	M10	M10	M10	M10	M10	M10	M10	M10
W	25	25	40	40	40	40	50	60
X	13/15	13/15	13/16	13/20	20	20	14	17
Y	21	20	25	23	40	40	22	26
Z	10.3	10.3	10.3	10.3	14	14	14	14

All dimensions in mm; 1 inch = 25.4 mm

Tolerances according: ISO 2768-m / EN 22768-m

Mechanical Data FN 5045

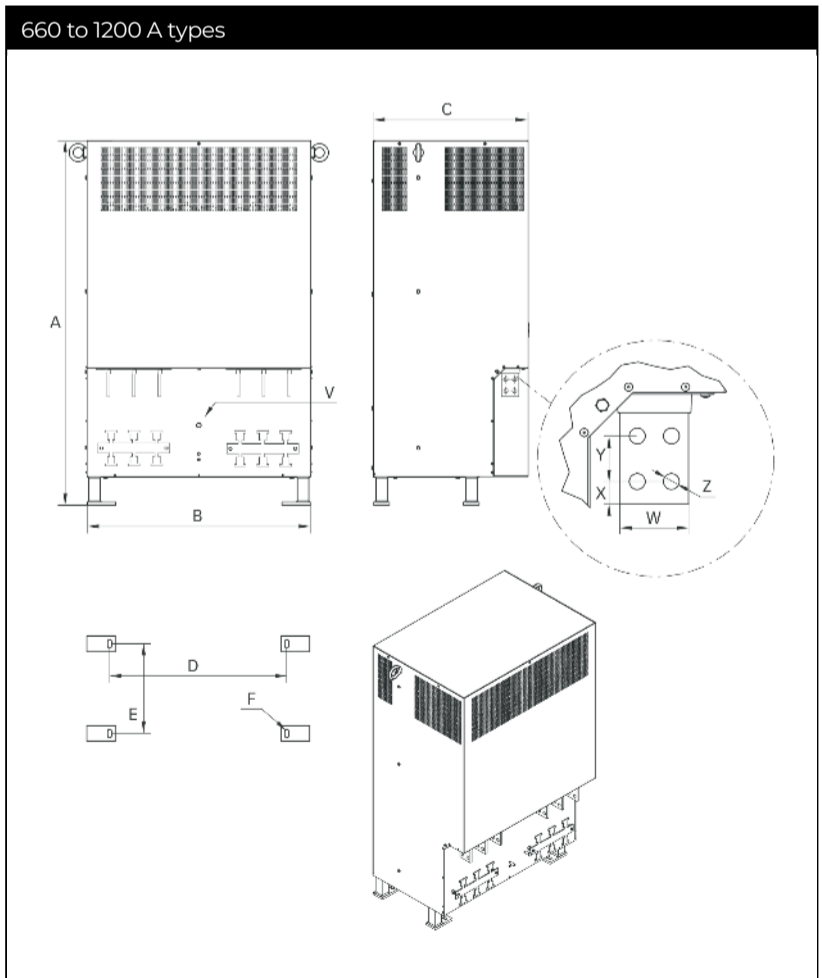
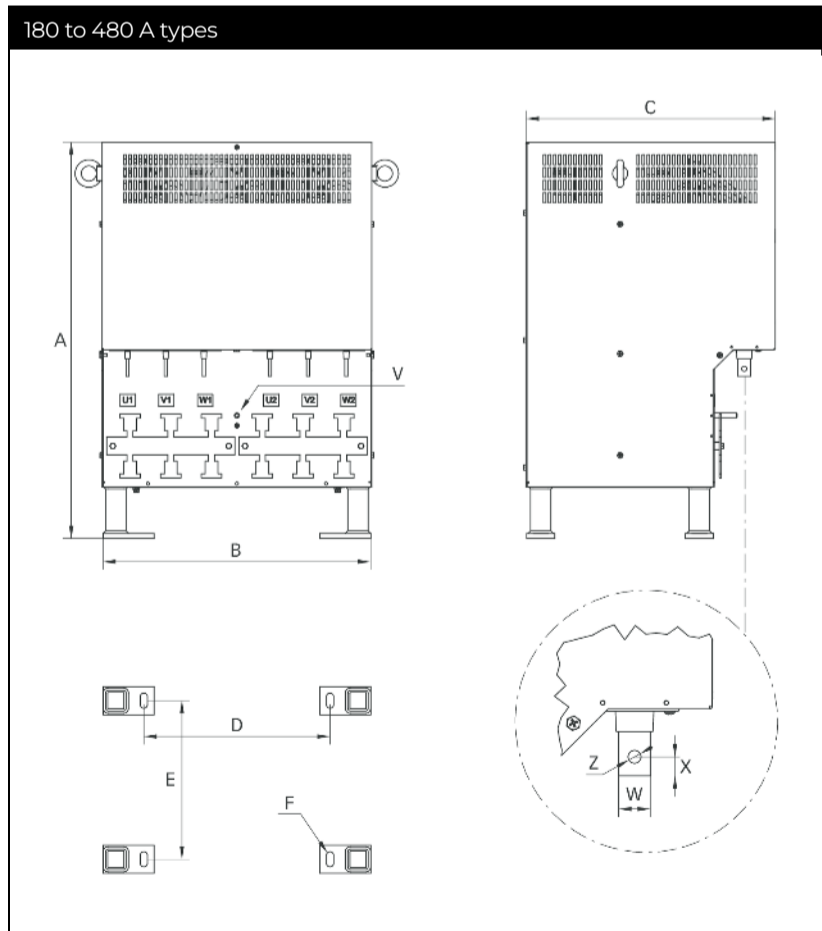
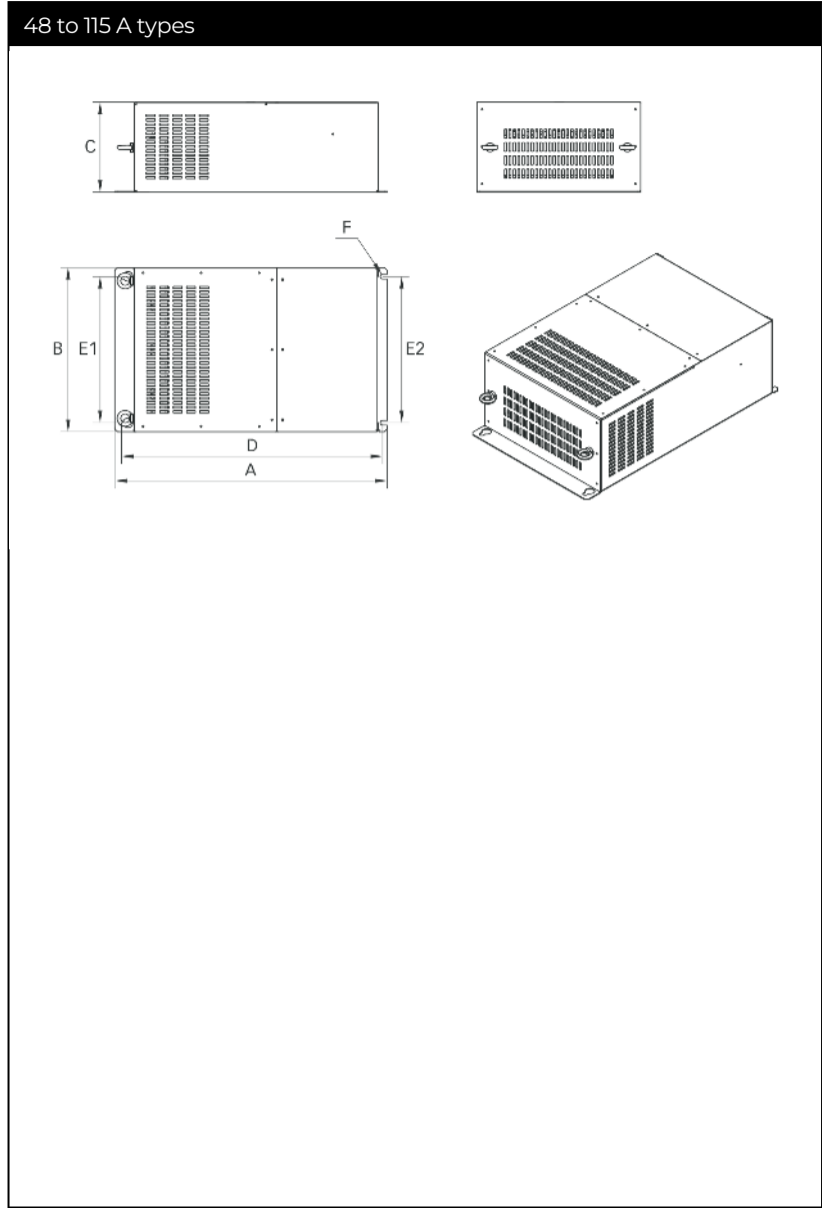
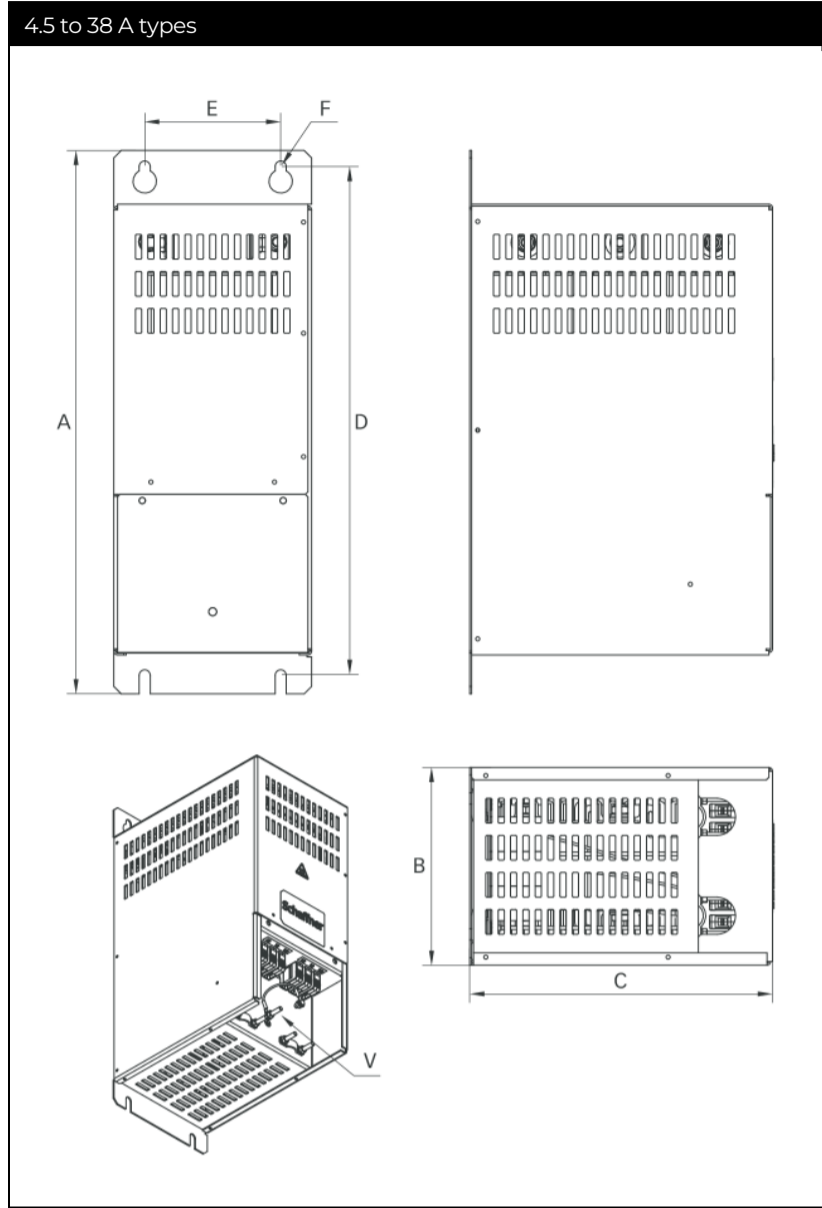











Dimensions FN 5045

	4.5 A	8 A	10 A	17 A	24 A	38 A	48 A	62 A	75 A	115 A	180 A	260 A	410 A	480 A	660 A	750 A	880 A	1200 A
A	330	330	330	440	440	440	515	515	615	615	650	650	780	780	1280	1280	1280	1280
B	100	100	100	160	160	160	320	320	370	370	508	508	538	538	794	794	794	794
C	165	165	165	245	245	245	153	153	203	203	400	400	494	494	498	498	550	550
D	310	310	310	412	412	412	488	488	590	590	336	336	336	336	622	622	622	622
E	60	60	60	110	110	110	280	280	330	330	243	243	312	312	315	315	315	315
F	7	7	7	9	9	9	9	9	11	11	14x30	14x30	14x30	14x30	14x30	14x30	14x30	14x30
J	M5	M5	M5	M5	M5	M5	M5	M5	M8	M8	M10	M10	M10	M10	M10	M10	M10	M10
W											20	20	25	40	40	40	40	60
X											15	15	15	15	20	20	20	20
Y															40	40	40	30/40
Z											9	9	10.2	10.2	14	14	14	14

All dimensions in mm; 1 inch = 25.4 mm

Tolerances according: ISO 2768-m / EN 22768-m

Filter Output Connector Cross Sections

	-33	-34	-35	-44	-82
					
Solid wire	16 mm ²	35 mm ²	50 mm ²	10 mm ²	0.75 - 2.5 mm ²
Flex wire	10 mm ²	25 mm ²	50 mm ²	6 mm ²	1.0 - 2.5 mm ²
AWG type wire	AWG 6	AWG 2	AWG 1/0	AWG 8	AWG 18 - 12
Recommended torque	1.5-1.8 Nm	4.0-4.5 Nm	7-8 Nm	1.5-1.8 Nm	1.0-1.2 Nm
					
Solid wire	0.75-4.0 mm ²	2.5-10.0 mm ²	2.5-25.0 mm ²	0.75-50 mm ²	16.0-50.0 mm ²
Flex wire	1.0-4.0 mm ²	4.0-10.0 mm ²	4.0-16.0 mm ²	0.75-35 mm ²	25.0-50.0 mm ²
AWG type wire	AWG 18-10	AWG 18-6	AWG 22-4	AWG 18-0/1	AWG 6-0
Recommended torque	1.5-1.8 Nm	4.0-4.5 Nm	1.5-1.8 Nm	3.2-3.7 Nm	6.0-8.0 Nm

Please visit www.schaffner.com to find more details on filter connectors.

Headquarters, Global Innovation and Development

Switzerland

Schaffner Holding AG

Industrie Nord
Nordstrasse 11e
4542
Luterbach
+41 32 681 66 26
info@schaffner.com

Sales and Application Centers

Switzerland

Schaffner EMV AG

Industrie Nord
Nordstrasse 11e
4542
Luterbach
+41 32 681 66 26
switzerlandsales@schaffner.com

Singapore

Schaffner EMC Pte Ltd.

Blk 3015A Ubi Road 1, #05-09, Kampong Ubi
Industrial Estate
408705
Singapore
+65 63773283
singaporesales@schaffner.com

China

Schaffner EMC Ltd. Shanghai

T20-3 C, No 565 Chuangye Road, Pudong
district
201201
Shanghai
+86 2138139500
cschina@schaffner.com

To find your local partner within Schaffner's global network schaffner.com

© 2022 Schaffner Group

The content of this document has been carefully checked and understood. However, neither Schaffner nor its subsidiaries assume any liability whatsoever for any errors or inaccuracies of this document and the consequences thereof. Published specifications are subject to change without notice. Product suitability for any area of application must ultimately be determined by the customer. In all cases, products must never be operated outside their published specifications. Schaffner does not guarantee the availability of all published products. This disclaimer shall be governed by substantive Swiss law and resulting disputes shall be settled by the courts at the place of business of Schaffner Holding AG. Latest publications and a complete disclaimer can be downloaded from the Schaffner website. All trademarks recognized.