

EJECTION LATCHES OMITTED IN THIS VIEW FOR CLARITY

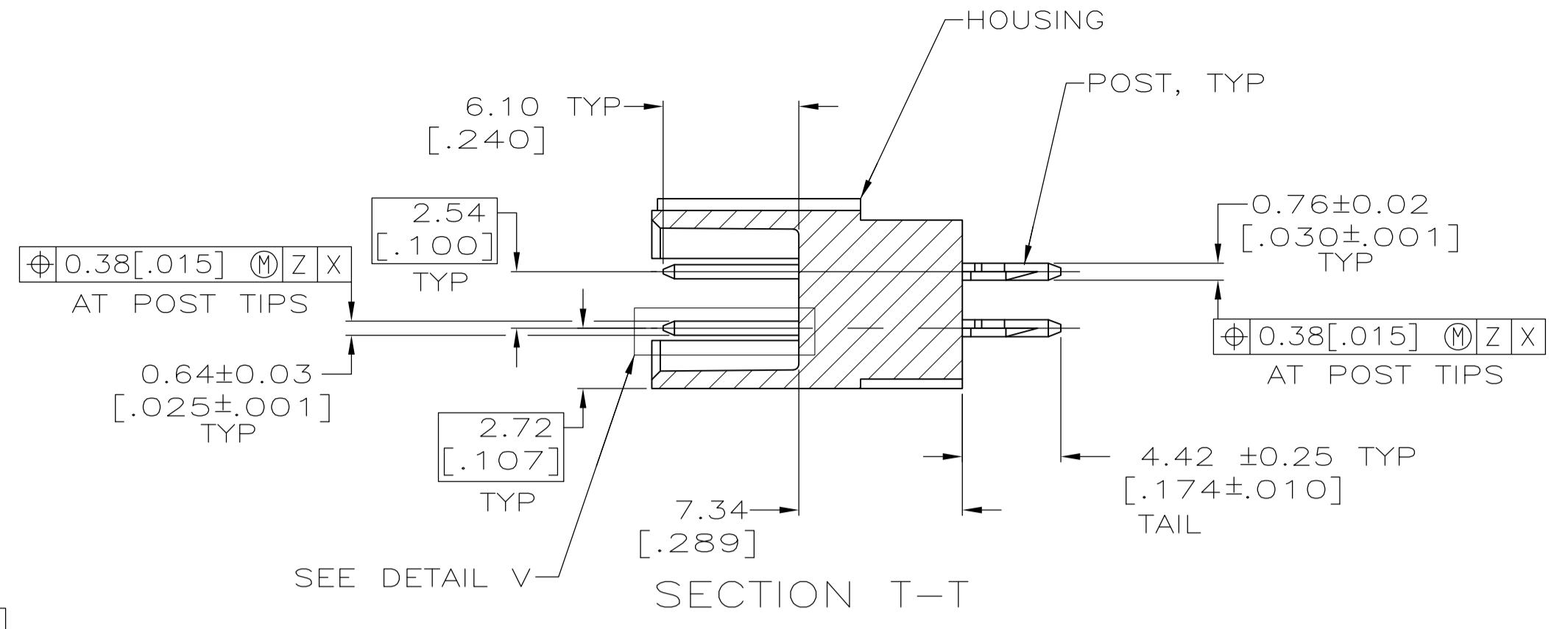

- △ COORDINATE DIMENSION APPLIES FROM BASIC LOCATION.
- △ 10 POSITION SIZE CONTAINS ONLY ONE SLOT FOR SNAP-IN POLARIZER (MILITARY POLARIZATION), LOCATED AS SHOWN.
- △ 10 POSITION SIZE CONTAINS ONLY ONE SLOT FOR DUAL POLARIZATION, LOCATED AS SHOWN.
- △ REFER TO APPLICATION SPECIFICATION 114-40020 FOR HOLE SIZE AND FINISH RECOMMENDATIONS.
- △ DISTANCE REQUIRED BY EJECTION LATCHES IN THE OPEN POSITION.
- △ MATERIAL HOUSING & LATCHES: GLASS FILLED NYLON OR POLYESTER, 94V-0 RATED, COLOR (SEE TABLE). POSTS: PHOSPHOR BRONZE
- △ FINISH POSTS: POSTS: GOLD FLASH OVER PALLADIUM-NICKEL PLATE, 0.76µm[.000030] MIN TOTAL ON THE LOCALIZED PLATE AREA, 2.54µm[.000100] MIN TIN PLATE ON THE TAIL, 1.27µm[.000050] MIN NICKEL UNDERPLATE ON THE ENTIRE POST. -OR- 0.76µm[.000030] MIN GOLD PLATE ON THE LOCALIZED PLATE AREA, 2.54µm[.000100] MIN TIN PLATE ON THE TAIL, 1.27µm[.000050] MIN NICKEL UNDERPLATE ON THE ENTIRE POST.
- △ SEATING TOOL REFERENCED IN APPLICATION SPECIFICATION CANNOT BE USED WITH HEADER ASSEMBLY WITH LATCHES.

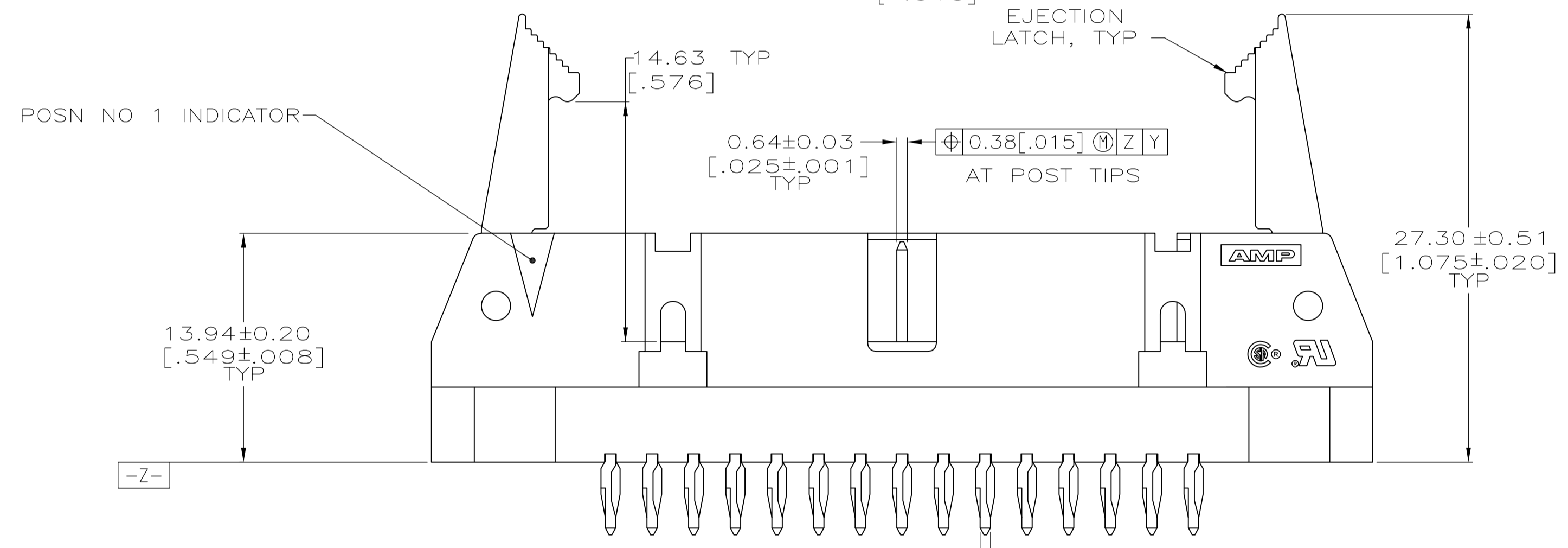
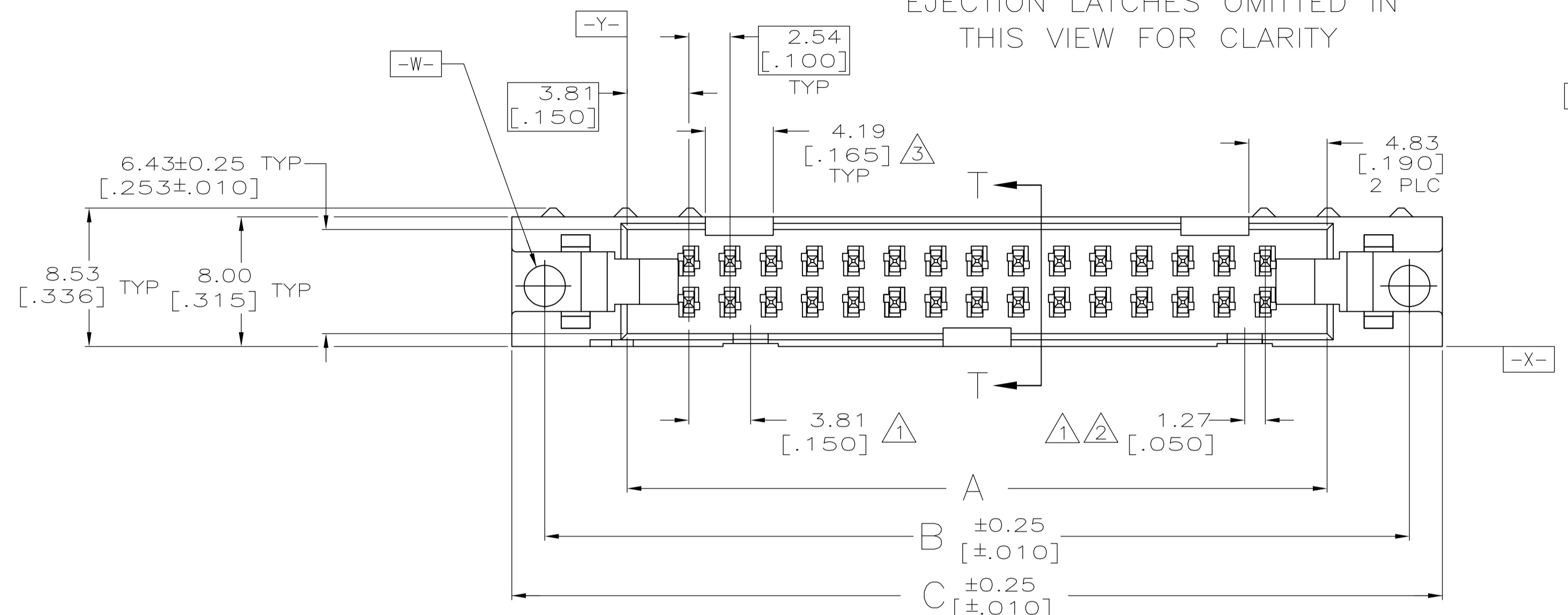
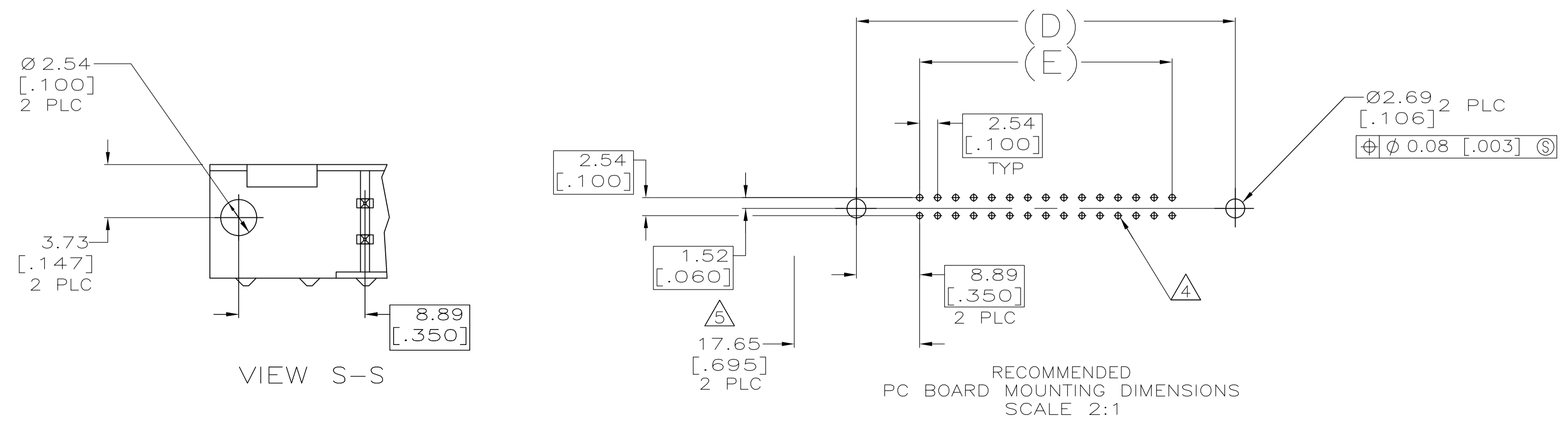
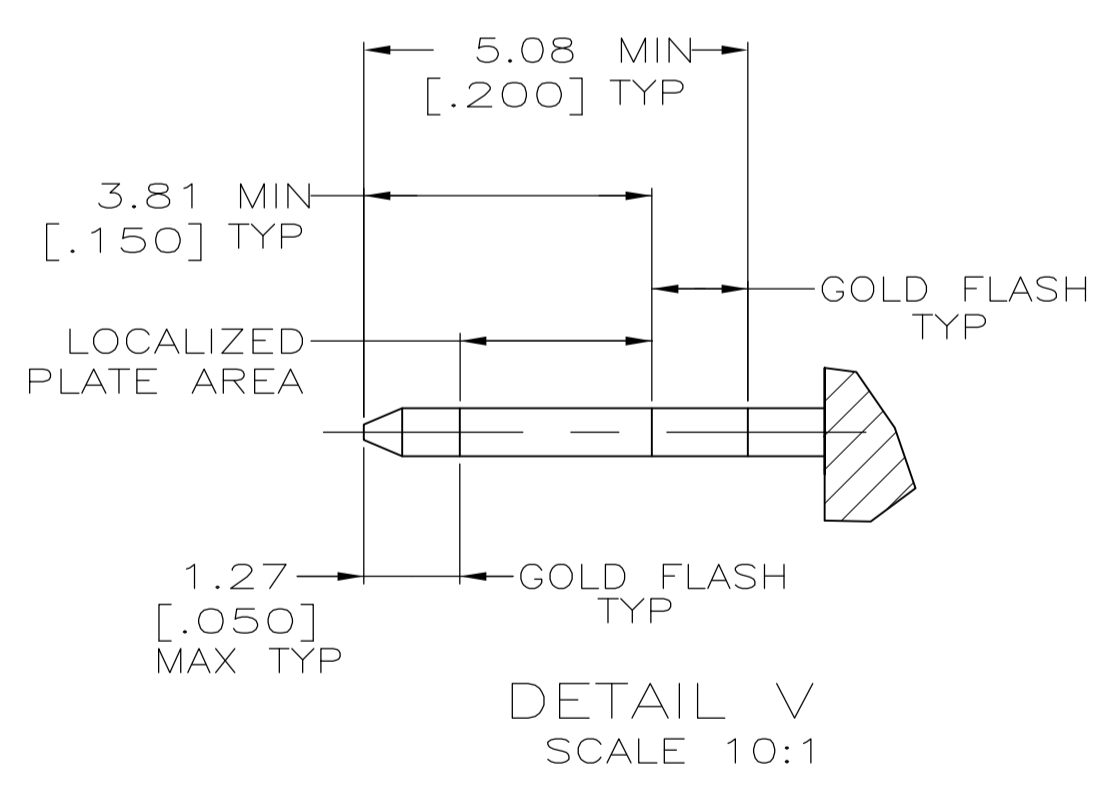

| STATUS   | COLOR                   | 60.96   | 78.74   | 82.80   | 78.74   | 68.58   | 50         | 3-5746443-0 |
|----------|-------------------------|---------|---------|---------|---------|---------|------------|-------------|
|          | BLUE                    | [2.400] | [3.100] | [3.260] | [3.100] | [2.700] |            |             |
|          | BLUE                    | 48.26   | 66.04   | 70.10   | 66.04   | 55.88   | 40         | 2-5746443-9 |
|          | BLUE                    | [1.900] | [2.600] | [2.760] | [2.600] | [2.200] |            |             |
|          | BLUE                    | 30.48   | 48.26   | 52.32   | 48.26   | 38.10   | 26         | 2-5746443-6 |
|          | BLUE                    | [1.200] | [1.900] | [2.060] | [1.900] | [1.500] |            |             |
|          | BLUE                    | 22.86   | 40.64   | 44.70   | 40.64   | 30.48   | 20         | 2-5746443-4 |
|          | BLUE                    | [.900]  | [1.600] | [1.760] | [1.600] | [1.200] |            |             |
| OBSOLETE | BLUE                    | 15.24   | 33.02   | 37.08   | 33.02   | 22.86   | 14         | 2-5746443-2 |
|          | BLUE                    | [.600]  | [1.300] | [1.460] | [1.300] | [.900]  |            |             |
|          | BLUE                    | 10.16   | 27.94   | 32.00   | 27.94   | 17.78   | 10         | 2-5746443-1 |
|          | BLUE                    | [.400]  | [1.100] | [1.260] | [1.100] | [.700]  |            |             |
|          | BLACK                   | 73.66   | 91.44   | 95.50   | 91.44   | 81.28   | 60         | 1-5746443-1 |
|          | BLACK                   | [2.900] | [3.600] | [3.760] | [3.600] | [3.200] |            |             |
|          | BLACK                   | 60.96   | 78.74   | 82.80   | 78.74   | 68.58   | 50         | 1-5746443-0 |
|          | BLACK                   | [2.400] | [3.100] | [3.260] | [3.100] | [2.700] |            |             |
|          | BLACK                   | 48.26   | 66.04   | 70.10   | 66.04   | 55.88   | 40         | 5746443-9   |
|          | BLACK                   | [1.900] | [2.600] | [2.760] | [2.600] | [2.200] |            |             |
|          | BLACK                   | 40.64   | 58.42   | 62.48   | 58.42   | 48.26   | 34         | 5746443-8   |
|          | BLACK                   | [1.600] | [2.300] | [2.460] | [2.300] | [1.900] |            |             |
|          | BLACK                   | 30.48   | 48.26   | 52.32   | 48.26   | 38.10   | 26         | 5746443-6   |
|          | BLACK                   | [1.200] | [1.900] | [2.060] | [1.900] | [1.500] |            |             |
| OBSOLETE | BLACK                   | 22.86   | 40.64   | 44.70   | 40.64   | 30.48   | 20         | 5746443-4   |
|          | BLACK                   | [.900]  | [1.600] | [1.760] | [1.600] | [1.200] |            |             |
|          | BLACK                   | 17.78   | 35.56   | 39.62   | 35.56   | 25.40   | 16         | 5746443-3   |
|          | BLACK                   | [.700]  | [1.400] | [1.560] | [1.400] | [1.000] |            |             |
|          | BLACK                   | 10.16   | 27.94   | 32.00   | 27.94   | 17.78   | 10         | 5746443-1   |
|          | BLACK                   | [.400]  | [1.100] | [1.260] | [1.100] | [.700]  |            |             |
|          | HOUSING AND LATCH COLOR | E       | D       | C       | B       | A       | NO OF POSN | PART NUMBER |

THIS DRAWING IS A CONTROLLED DOCUMENT.

|                         |  |                       |                    |                   |                |                  |   |
|-------------------------|--|-----------------------|--------------------|-------------------|----------------|------------------|---|
| DIMENSIONS: mm [INCHES] | TOLERANCES UNLESS OTHERWISE SPECIFIED: | APPROVED: M. WALMSLEY | DATE: 01-06-05     | NAME: M. WALMSLEY | DATE: 01-06-05 | TYCO ELECTRONICS | TYCO ELECTRONICS CORPORATION<br>HARRISBURG, PA 17105-3608 |
| 0 PLC ± -               | 1 PLC ± -                              | 2 PLC ± -             | 3 PLC ± 0.13[.005] | 4 PLC ± -         | ANGLES ± -     | PRODUCT SPEC     | HEADER ASSY, UNIVERSAL, AMP-LATCH                         |
|                         |  |                       |                    |                   |                | APPLICATION SPEC | 108-40019   |
|                         |  |                       |                    |                   |                | 114-40020        | SIZE: A1  |
|                         |  |                       |                    |                   |                | WEIGHT: -        | CAGE CODE: 00779  |
|                         |  |                       |                    |                   |                |                  | DRAWING NO: 5746443                                       |
|                         |  |                       |                    |                   |                |                  | RESTRICTED TO: -  |
|                         |  |                       |                    |                   |                |                  | SCALE: 4:1  |
|                         |  |                       |                    |                   |                |                  | SHEET 1 OF 1  |
|                         |  |                       |                    |                   |                |                  | REV F   |