

Product Specification

NHD-4.3-800480CF-ASXP-CTP

TFT (Thin-Film-Transistor) Color Liquid Crystal Display Module

NHD -	Newhaven Display
4.3 -	4.3" Diagonal
800480 -	800xRGBx480 Pixels
CF -	Model
A -	Built-in Driver / No Controller
S -	High Brightness, White LED Backlight
X -	TFT
P -	IPS, Wide Temperature
CTP -	Capacitive Touch Panel with Controller

Table of Contents

Document Revision History.....	2
Mechanical Drawing	3
Pin Description	4
Electrical Characteristics	5
Optical Characteristics	5
Capacitive Touch Panel Material Characteristics.....	6
Driver/ Controller Information.....	6
Capacitive Touch Panel Registers	7
Timing Characteristics - TFT	10
Timing Characteristics – Capacitive Touch Panel.....	12
Quality Information	15

Additional Resources

- **Support Forum:** <https://support.newhavendisplay.com/hc/en-us/community/topics>
- **GitHub:** <https://github.com/newhavendisplay>
- **Example Code:** <https://support.newhavendisplay.com/hc/en-us/categories/4409527834135-Example-Code/>
- **Knowledge Center:** https://www.newhavendisplay.com/knowledge_center.html
- **Quality Center:** https://www.newhavendisplay.com/quality_center.html
- **Precautions for using LCDs/LCMs:** <https://www.newhavendisplay.com/specs/precautions.pdf>
- **Warranty / Terms & Conditions:** <https://www.newhavendisplay.com/terms.html>



Document Revision History

Revision	Date	Description	Changed By
-	11/20/2019	Initial Release	PK
1	5/18/2020	Updated Static Electricity Test Condition	AS
2	11/19/2020	Corrected Recommended Molex Connector P/N	AS
3	01/17/2022	Updated Electrical Characteristics for Touch panel, Touch panel registers, Touch panel controller IC changed to FT5426-003,	JT
4	10/21/2022	CTP Gesture ID Values Updated	KL
5	02/02/2023	Mechanical Drawing Format Updated	KL

Mechanical Drawing

Newhaven Display

NHD-4.3-800480CF-ASXP-CTP

Date Code

Part Label (type/format may vary)

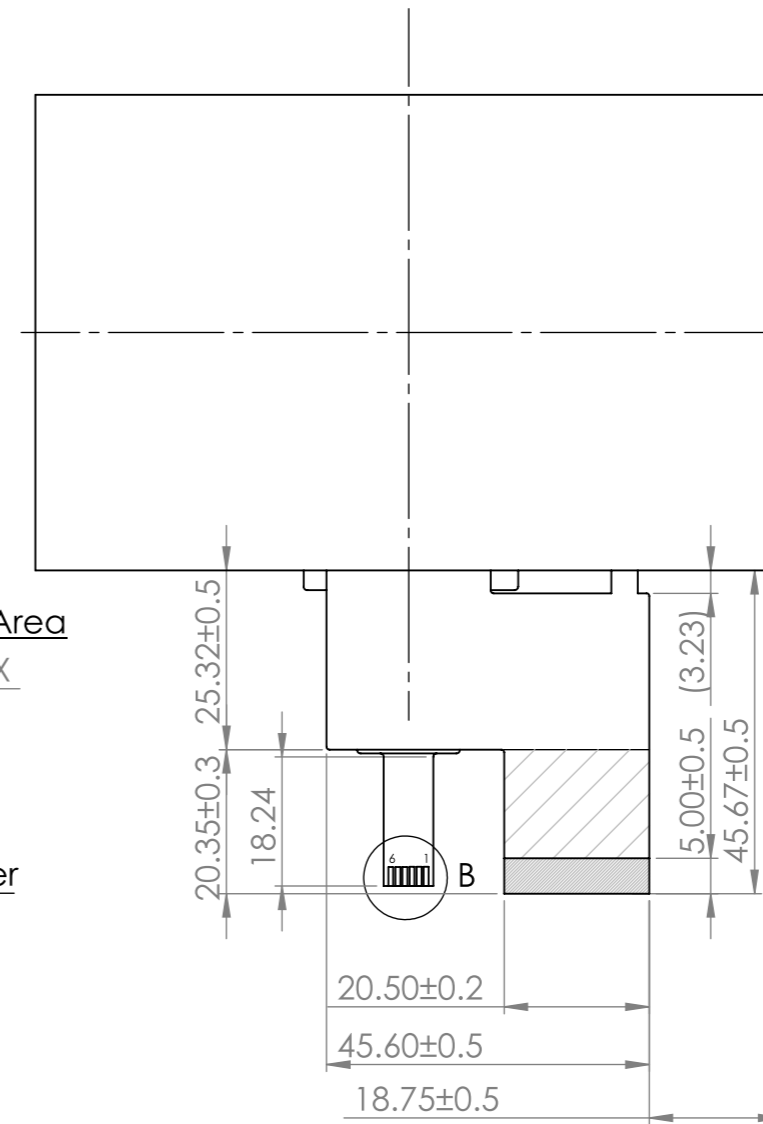
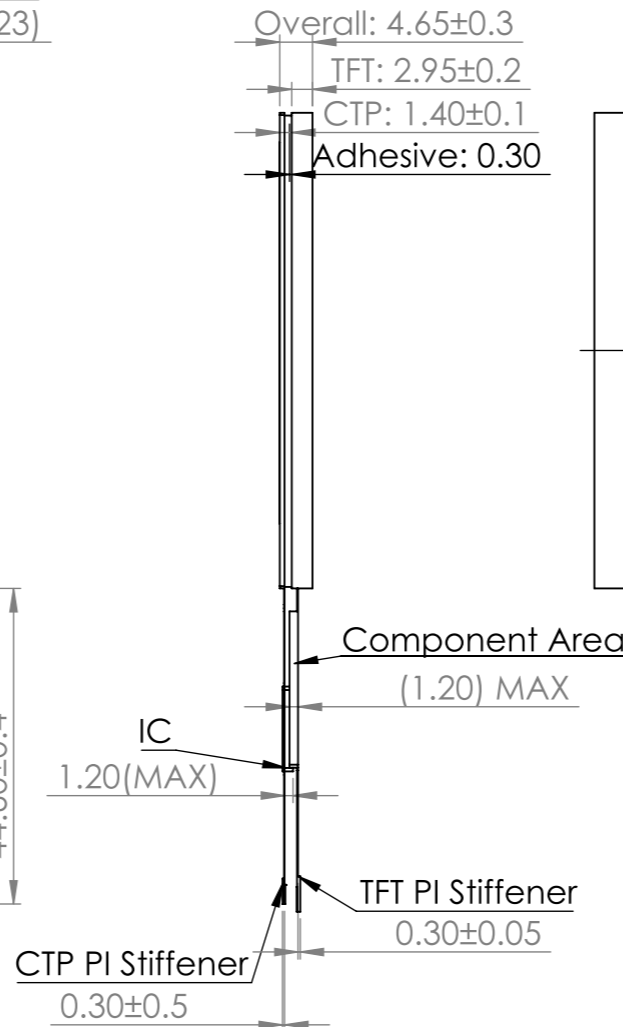
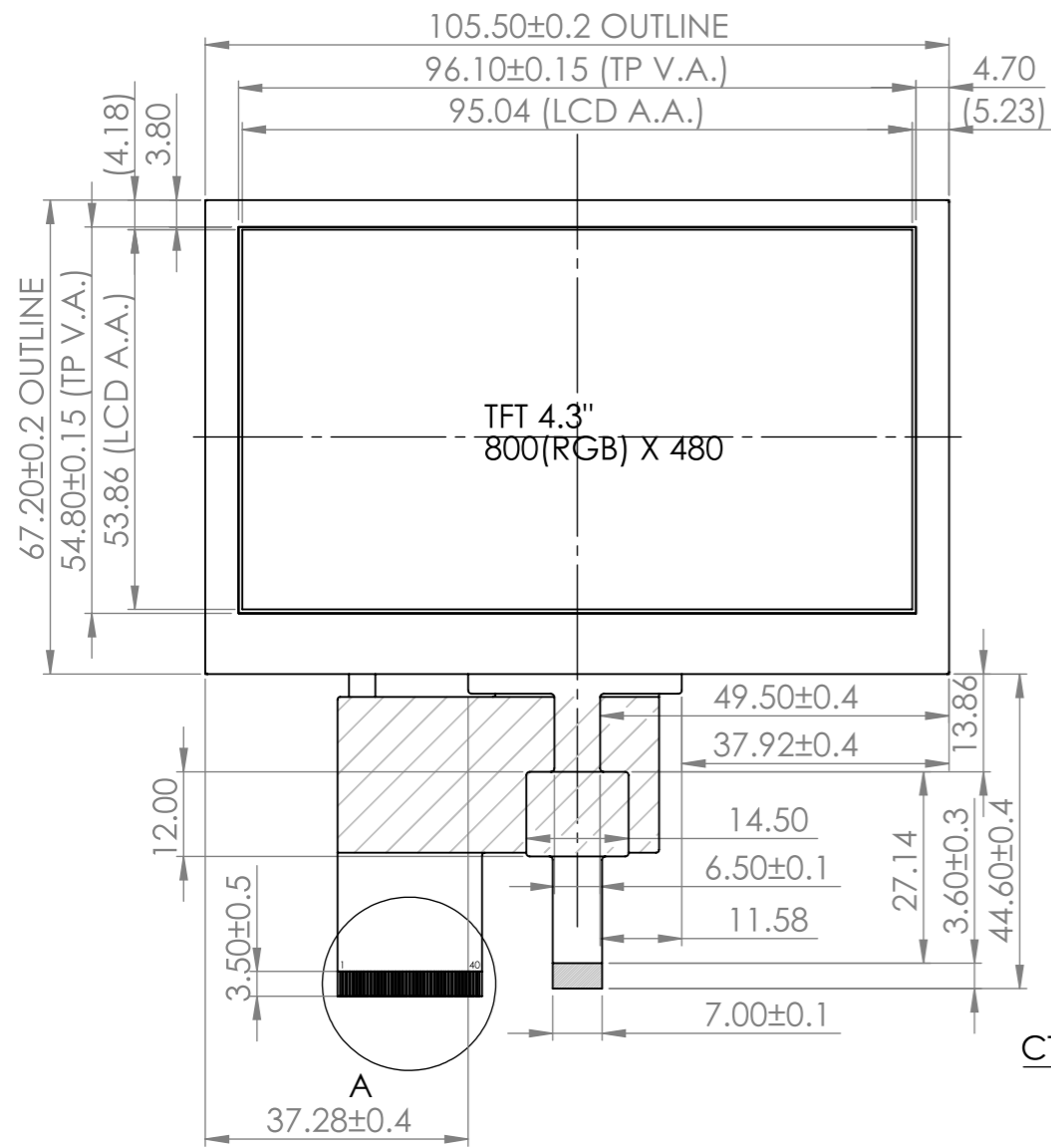

Pin Assignment

Pin No.	Symbol
1	LEDK
2	LEDA
3	GND
4	V _{DD}
5-12	[R0-R7]
13-20	[G0-G7]
21-28	[B0-B7]
29	GND
30	CLK
31	DISP
32	HSYNC
33	VSYNC
34	DEN
35	NC
36	GND
37	NC
38	NC
39	NC
40	NC

Pin No.	Symbol
1	VDD
2	GND
3	SCL
4	SDA
5	INT
6	RESET

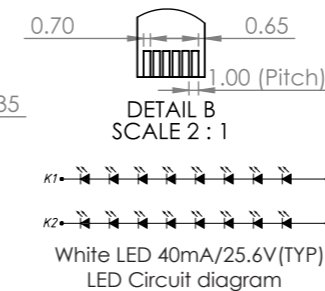
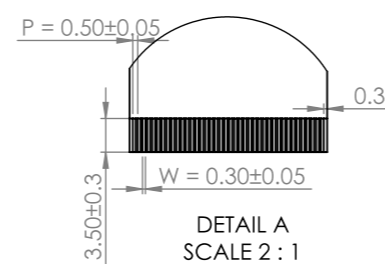

Product Description: 4.3" 800x480 IPS TFT w/ Capacitive Touch

1. Driver IC: EK9716B TFT, FT5426-003 CTP
2. Interface: 24-bit Parallel RGB, I²C CTP
3. Power Requirement: 3.3V TFT, 25.6V/40mA Backlight, 3.3V CTP
4. Optical Features: Normally Black, Transmissive, 723cd/m²
5. Recommended FFC Connector:

TFT: 40pin 0.5mm pitch; Ex. Molex 54104-4031

CTP: 6pin 1.0mm pitch; Ex. Molex 52271-0679

Standard Tolerance: (Unless otherwise specified) Linear: ±0.3mm		
	Drawing/Part Number: NHD-4.3-800480CF-ASXP-CTP	Revision: -
Unless otherwise specified: • Dimensions are in Millimeters • Third Angle Projection	Drawn By: K. Lewis	Approved By: K. Lewis
	Drawn Date: 02/02/2023	Approved Date: 02/02/2023
This drawing is solely the property of Newhaven Display International, Inc. The information it contains is not to be disclosed, reproduced or copied in whole or part without written approval from Newhaven Display.		

Pin Description

Pin No.	Symbol	External Connection	Function Description
1	LED-	Power Supply	Backlight Cathode (Ground)
2	LED+	Power Supply	Backlight Anode (25.6V @ 40 mA)
3	GND	Power Supply	Ground
4	V _{DD}	Power Supply	Supply Voltage for LCD and logic (3.3V)
5-12	[R0-R7]	MPU	Red Data signals
13-20	[G0-G7]	MPU	Green Data signals
21-28	[B0-B7]	MPU	Blue Data signals
29	GND	Power Supply	Ground
30	CLK	MPU	Data sample Clock signal (Falling Edge Triggered)
31	DISP	MPU	Display Control Signal (High: ON (Default), Low: Standby)
32	HSYNC	MPU	Line synchronization signal
33	VSYNC	MPU	Frame synchronization signal
34	DEN	MPU	Data Enable signal
35	BIST	MPU	Built in Self-Test. BIST = H: Self-Test Enabled. BIST = L: Normal Operation (Default)
36	GND	Power Supply	Ground
37	NC	-	No Connect
38	NC	-	No Connect
39	NC	-	No Connect
40	NC	-	No Connect

Recommended LCD connector: 0.5mm pitch 40-Conductor FFC. **Molex P/N:** 54104-4031 (Top Contact)

Capacitive Touch Panel:

Pin No.	Symbol	External Connection	Function Description
1	V _{DD}	Power Supply	Power supply for logic (3.3V)
2	GND	Power Supply	Ground
3	SCL	MPU	Serial I2C Clock (Requires pull-up resistor)
4	SDA	MPU	Serial I2C Data (Requires pull-up resistor)
5	/INT	MPU	Interrupt signal from T.P. module to host (Requires pull-up resistor)
6	/RESET	MPU	Active LOW Reset signal (Do not tie to V _{DD})

Recommended connector: 1.0mm pitch 6-Conductor FFC. **Molex P/N:** 52271-0679 (Bottom Contact)

Electrical Characteristics

TFT:

Item	Symbol	Condition	Min.	Typ.	Max.	Unit
Operating Temperature Range	T _{OP}	Absolute Max	-20	-	+70	°C
Storage Temperature Range	T _{ST}	Absolute Max	-30	-	+80	°C
Supply Voltage	V _{DD}	-	2.4	3.3	3.6	V
Supply Current	I _{DD}	V _{DD} = 3.3V	80	160	240	mA
"H" level input	V _{IH}	-	0.7 * V _{DD}	-	V _{DD}	V
"L" level input	V _{IL}	-	GND	-	0.3 * V _{DD}	V
Backlight Supply Current	I _{LED}	T _{OP} = 25°C	30	40	50	mA
Backlight Supply Voltage	V _{LED}	I _{LED} = 40mA	22.4	25.6	27.2	V
Backlight Lifetime*	-	T _{OP} = 25°C	30,000	50,000	-	Hrs.

*Backlight is current driven. Backlight lifetime is rated as Hours until **half-brightness**, under normal operating conditions.

Capacitive Touch Panel:

Item	Symbol	Condition	Min.	Typ.	Max.	Unit
Operating Temperature Range	T _{OP}	Absolute Max	-20	-	+70	°C
Storage Temperature Range	T _{ST}	Absolute Max	-30	-	+80	°C
Supply Voltage	V _{DD}	-	2.7	3.3	3.6	V
Supply Current (Operating)	I _{DD}	V _{DD} = 3.3V	12	-	14.5	mA
Supply Current (Hibernate)	I _{DD}	T _{OP} = 25°C	-	1.0	-	μA
"H" level input	V _{IH}	-	0.7 * V _{DD}	-	V _{DD}	V
"L" level input	V _{IL}	-	GND	-	0.3 * V _{DD}	V
"H" level output	V _{OH}	-	0.7 * V _{DD}	-	V _{DD}	V
"L" level output	V _{OL}	-	GND	-	0.3 * V _{DD}	V

Optical Characteristics

Item	Symbol	Condition	Min.	Typ.	Max.	Unit	
Optimal Viewing Angles	Top	CR ≥ 10	70	80	-	°	
	Bottom		70	80	-	°	
	Left		70	80	-	°	
	Right		70	80	-	°	
Contrast Ratio	CR	-	640	800	-	-	
Luminance	L _V	I _{LED} = 40 mA	578	723	-	cd/m ²	
Response Time	Rise + Fall	T _R +T _F	-	30	40	ms	
Chromaticity	Red	X _R	-	0.558	0.598	0.638	-
		Y _R	-	0.305	0.345	0.385	-
	Green	X _G	-	0.335	0.375	0.415	-
		Y _G	-	0.521	0.561	0.601	-
	Blue	X _B	-	0.103	0.143	0.183	-
		Y _B	-	0.062	0.102	0.142	-
	White	X _W	-	0.269	0.309	0.349	-
		Y _W	-	0.279	0.319	0.355	-

Capacitive Touch Panel Characteristics

Property	Value
Surface Hardness	≥6H
Transmittance	>85%
Multitouch Points	5

Driver/ Controller Information

TFT

Built-in EK9716B Source driver: <https://support.newhavendisplay.com/hc/en-us/articles/4414491960599-EK9716B>

Built-in EK73002AB2 Gate driver: <https://support.newhavendisplay.com/hc/en-us/articles/4414491516183-EK73002AB2>

Capacitive Touch Panel:

Built-in FT5426-003 controller: <https://support.newhavendisplay.com/hc/en-us/articles/4414392845079-FT5x26>



Capacitive Touch Panel Registers

Register No.	Access	Register Name	Bits	Value	Description
01h	RO	Gesture ID	[7:0]	1Ch	Swipe Up
				14h	Swipe Down
				10h	Swipe Left
				18h	Swipe Right
				48h	Zoom In
				49h	Zoom Out
				00	No gesture
02h	RO	Touch Points	[7:0]	0-Ah	0: No touch detected A: 10 touch points detected
03h	RO	TOUCH1_Event_Flag	[7:6]	0	Put Down
				1	Put Up
				2	Contact
				3	Reserved
03h	RO	TOUCH1_XH	[3:0]	0-1	Upper 4 bits of X touch coordinate
04h	RO	TOUCH1_XL	[7:0]	00 - FFh	Lower 8 bits of X touch coordinate
05h	RO	TOUCH1_YH	[3:0]	0-1	Upper 4 bits of Y touch coordinate
06h	RO	TOUCH1_YL	[7:0]	00 - FFh	Lower 8 bits of Y touch coordinate
07h	RO	TOUCH1_Weight	[7:0]		Touch Weight
08h	RO	TOUCH1_Misc	[3:0]	00-0Fh	Touch Area
09h	RO	TOUCH2_Event_Flag	[7:6]	0	Put Down
				1	Put Up
				2	Contact
				3	Reserved
09h	RO	TOUCH1_XH	[3:0]	0-1	Upper 4 bits of X touch coordinate
0Ah	RO	TOUCH2_XL	[7:0]	00 - FFh	Lower 8 bits of X touch coordinate
0Bh	RO	TOUCH2_YH	[3:0]	0-1	Upper 4 bits of Y touch coordinate
0Ch	RO	TOUCH2_YL	[7:0]	00 - FFh	Lower 8 bits of Y touch coordinate
0Dh	RO	TOUCH2_Weight	[7:0]		Touch Weight
0Eh	RO	TOUCH2_Misc	[3:0]	00-0Fh	Touch Area
0Fh	RO	TOUCH3_Event_Flag	[7:6]	0	Put Down
				1	Put Up
				2	Contact
				3	Reserved
0Fh	RO	TOUCH3_XH	[3:0]	0-1	Upper 4 bits of X touch coordinate
10	RO	TOUCH3_XL	[7:0]	00 - FFh	Lower 8 bits of X touch coordinate
11h	RO	TOUCH3_YH	[3:0]	0-1	Upper 4 bits of Y touch coordinate
12h	RO	TOUCH3_YL	[7:0]	00 - FFh	Lower 8 bits of Y touch coordinate
13h	RO	TOUCH3_Weight	[7:0]		Touch Weight
14h	RO	TOUCH3_Misc	[3:0]	00-0Fh	Touch Area
15h	RO	TOUCH4_Event_Flag	[7:6]	0	Put Down
				1	Put Up
				2	Contact
				3	Reserved
15h	RO	TOUCH4_XH	[3:0]	0-1	Upper 4 bits of X touch coordinate
16h	RO	TOUCH4_XL	[7:0]	00 - FFh	Lower 8 bits of X touch coordinate
17h	RO	TOUCH4_YH	[3:0]	0-1	Upper 4 bits of Y touch coordinate
18h	RO	TOUCH4_YL	[7:0]	00 - FFh	Lower 8 bits of Y touch coordinate
1Ah	RO	TOUCH4_Misc	[3:0]	00-0Fh	Touch Area
1Bh	RO	TOUCH5_Event_Flag	[7:6]	0	Put Down
				1	Put Up
				2	Contact
				3	Reserved

Register No.	Access	Register Name	Bits	Value	Description
1Bh	RO	TOUCH5_XH	[3:0]	0 -1	Upper 4 bits of X touch coordinate
1Ch	RO	TOUCH5_XL	[7:0]	00 - FFh	Lower 8 bits of X touch coordinate
1Dh	RO	TOUCH5_YH	[3:0]	0 -1	Upper 4 bits of Y touch coordinate
1Eh	RO	TOUCH5_YL	[7:0]	00 - FFh	Lower 8 bits of Y touch coordinate
1Fh	RO	TOUCH5_Weight	[7:0]		Touch Weight
20	RO	TOUCH5_Misc	[3:0]	00-0Fh	Touch Area
21h	RO	TOUCH6_Event_Flag	[7:6]	0	Put Down
				1	Put Up
				2	Contact
				3	Reserved
21h	RO	TOUCH6_XH	[3:0]	0 -1	Upper 4 bits of X touch coordinate
22h	RO	TOUCH6_XL	[7:0]	00 - FFh	Lower 8 bits of X touch coordinate
23h	RO	TOUCH6_YH	[3:0]	0 -1	Upper 4 bits of Y touch coordinate
24h	RO	TOUCH6_YL	[7:0]	00 - FFh	Lower 8 bits of Y touch coordinate
25h	RO	TOUCH6_Weight	[7:0]		Touch Weight
26h	RO	TOUCH6_Misc	[3:0]	00-0Fh	Touch Area
27h	RO	TOUCH7_Event_Flag	[7:6]	0	Put Down
				1	Put Up
				2	Contact
				3	Reserved
27h	RO	TOUCH7_XH	[3:0]	0 -1	Upper 4 bits of X touch coordinate
28h	RO	TOUCH7_XL	[7:0]	00 - FFh	Lower 8 bits of X touch coordinate
29h	RO	TOUCH7_YH	[3:0]	0 - 1	Upper 4 bits of Y touch coordinate
2Ah	RO	TOUCH7_YL	[7:0]	00 - FFh	Lower 8 bits of Y touch coordinate
2Bh	RO	TOUCH7_Weight	[7:0]		Touch Weight
2Ch	RO	TOUCH7_Misc	[3:0]	00-0Fh	Touch Area
2Dh	RO	TOUCH8_Event_Flag	[7:6]	0	Put Down
				1	Put Up
				2	Contact
				3	Reserved
2Dh	RO	TOUCH8_XH	[3:0]	0 - 1	Upper 4 bits of X touch coordinate
2Eh	RO	TOUCH8_XL	[7:0]	00 - FFh	Lower 8 bits of X touch coordinate
2Fh	RO	TOUCH8_YH	[3:0]	0 - 1	Upper 4 bits of Y touch coordinate
30	RO	TOUCH8_YL	[7:0]	00 - FFh	Lower 8 bits of Y touch coordinate
31h	RO	TOUCH8_Weight	[7:0]		Touch Weight
32h	RO	TOUCH8_Misc	[3:0]	00-0Fh	Touch Area
33h	RO	TOUCH9_Event_Flag	[7:6]	0	Put Down
				1	Put Up
				2	Contact
				3	Reserved
33h	RO	TOUCH9_XH	[3:0]	0 - 1	Upper 4 bits of X touch coordinate
34h	RO	TOUCH9_XL	[7:0]	00 - FFh	Lower 8 bits of X touch coordinate
35h	RO	TOUCH9_YH	[3:0]	0 - 1	Upper 4 bits of Y touch coordinate
36h	RO	TOUCH9_YL	[7:0]	00 - FFh	Lower 8 bits of Y touch coordinate
37h	RO	TOUCH9_Weight	[7:0]		Touch Weight
38h	RO	TOUCH9_Misc	[3:0]	00 - 0Fh	Touch Area
39h	RO	TOUCH10_Event_Flag	[7:6]	0	Put Down
				1	Put Up
				2	Contact
				3	Reserved
39h	RO	TOUCH10_XH	[3:0]	0 - 1	Upper 4 bits of X touch coordinate
3Ah	RO	TOUCH10_XL	[7:0]	00 - FFh	Lower 8 bits of X touch coordinate
3Bh	RO	TOUCH10_YH	[3:0]	0 - 1	Upper 4 bits of Y touch coordinate
3Ch	RO	TOUCH10_YL	[7:0]	00 - FFh	Lower 8 bits of Y touch coordinate

Register No.	Access	Register Name	Bits	Value	Description
3Dh	RO	TOUCH10_Weight	[7:0]	00-FFh	Touch Weight
3Eh	RO	TOUCH10_Misc	[3:0]	00-0Fh	Touch Area
A1h	RO	ID_G_LIB_VERSION_H	[7:0]	00-FFh	App library version high-byte Default: 0
A2h	RO	ID_G_LIB_VERSION_L	[7:0]	00-FFh	App library version low-byte Default: 2h
A3h	RO	ID_G_CHIPER_HIGH	[7:0]	00-FFh	Chip Vendor ID Default: 54h
A6h	RO	ID_G_FIRMID	[7:0]	00-FFh	Firmware ID Number Default: 88
A8h	RO	ID_G_VENODRID	[7:0]	00-FFh	CTPM Vendor's Chip ID Default: 92h

Timing Characteristics - TFT

Parallel RGB Input Timing Requirements

Item		Symbol	Min.	Typ.	Max.	Unit	Remark
DCLK Frequency		Fclk	28.2	29.2	40	MHz	-
DLCK Period		Tclk	25	34	-	ns	-
HSYNC	Period Time	Th	908	928	1088	DCLK	Thw + Thbp = 88 DLCK is fixed
	Display Period	Thdisp	800			DCLK	
	Pulse Width	Thw	1	48	87	DCLK	
	Back Porch	Thbp	87	40	1	DCLK	
	Front Porch	Thfp	20	40	200	DCLK	
VSYNC	Period Time	Tv	517	525	613	H	Tvw + Tvbp = 32 H is fixed
	Display Period	Tvdisp	480			H	
	Pulse Width	Tvw	1	1	3	H	
	Back Porch	Tvbp	31	31	29	H	
	Front Porch	Tvfp	5	13	101	H	

DE Mode Timing Diagram

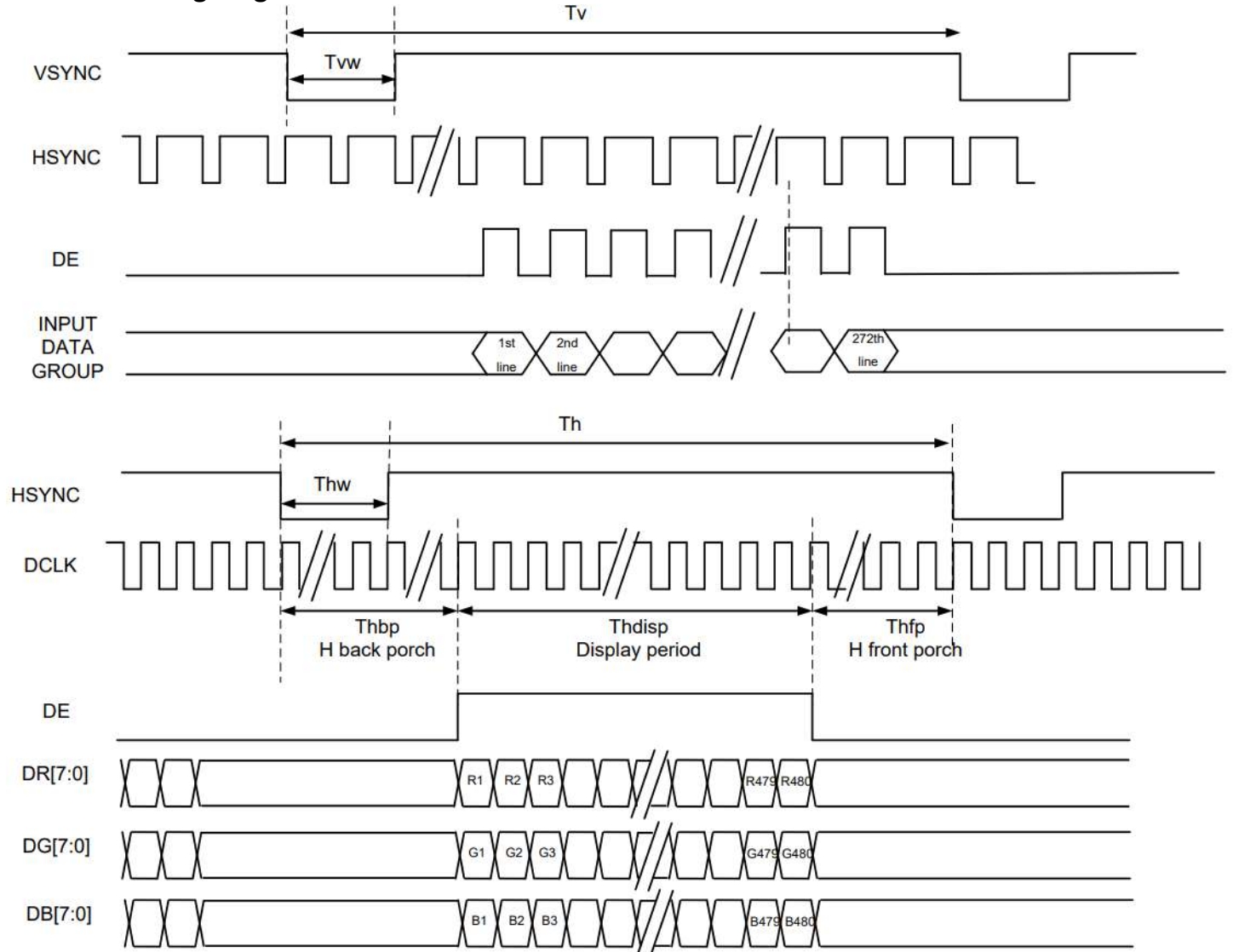

Input Setup Timing Requirements

Item	Symbol	Min.	Typ.	Max.	Unit	Conditions
V _{DD} Power Source Slew Time	T _{por}	-	-	20	ms	From 0V to 90% V _{DD}
CLK cycle time	T _{cph}	25	-	-	ns	-
CLK pulse duty	T _{cwh}	40	50	60	%	-
Data setup time	T _{dsu}	8	-	-	ns	-
Data hold time	T _{dhd}	8	-	-	ns	-
DEN setup time	T _{esu}	8	-	-	ns	-
DEN hold time	T _{ehd}	8	-	-	ns	-

Input Setup Timing Diagram

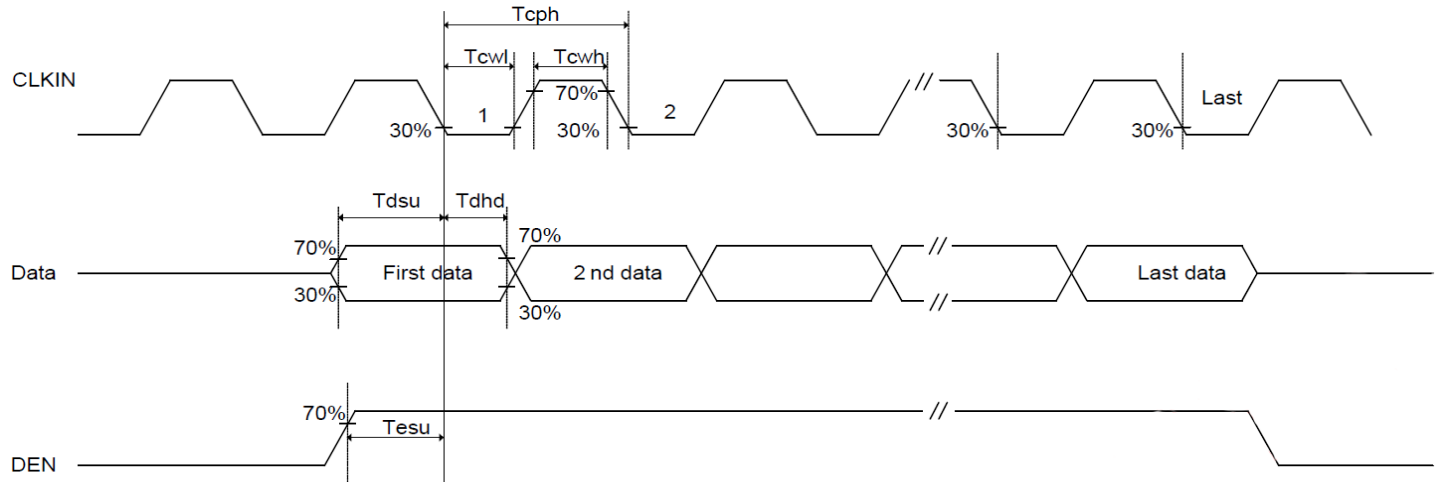

Timing Characteristics – Capacitive Touch Panel

Data Transfer Format

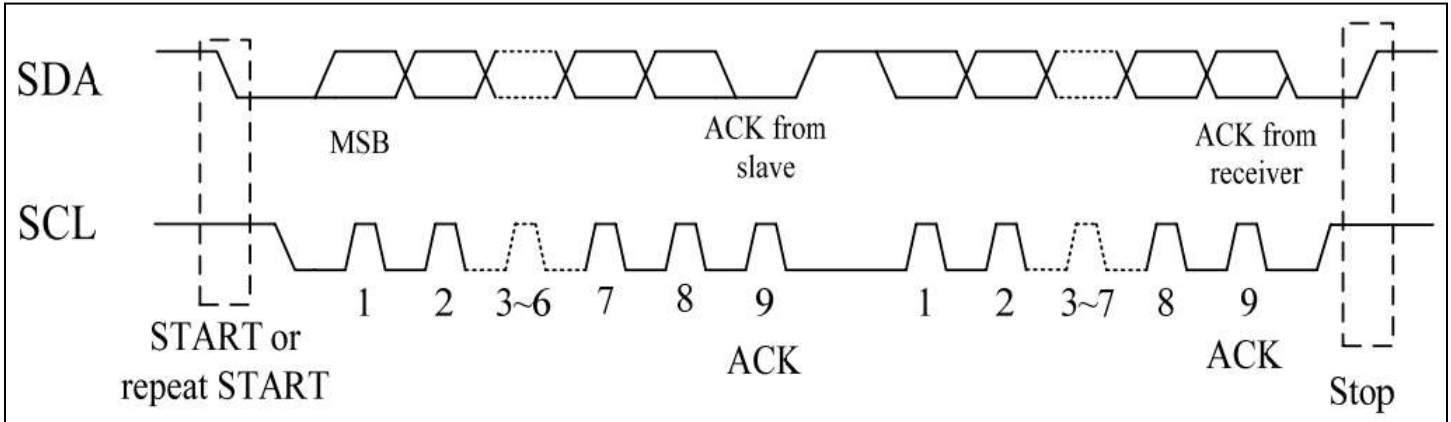

Parameter	Min	Max	Unit
SCL Frequency	0	400	KHz
Bus free time between a STOP & START condition	1.3	-	μs
Hold time Repeated START condition	0.6	-	μs
Data Setup Time	100	-	ns
Setup time for a repeated START condition	0.6	-	μs
Setup time for a STOP condition	0.6	-	μs

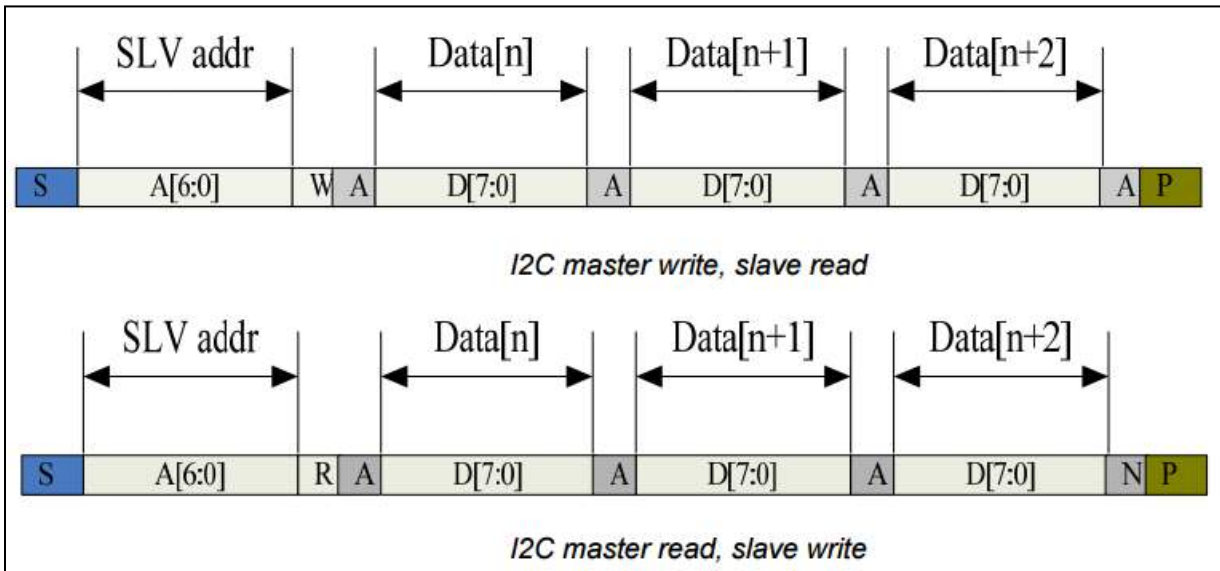

Power ON/Reset Sequence

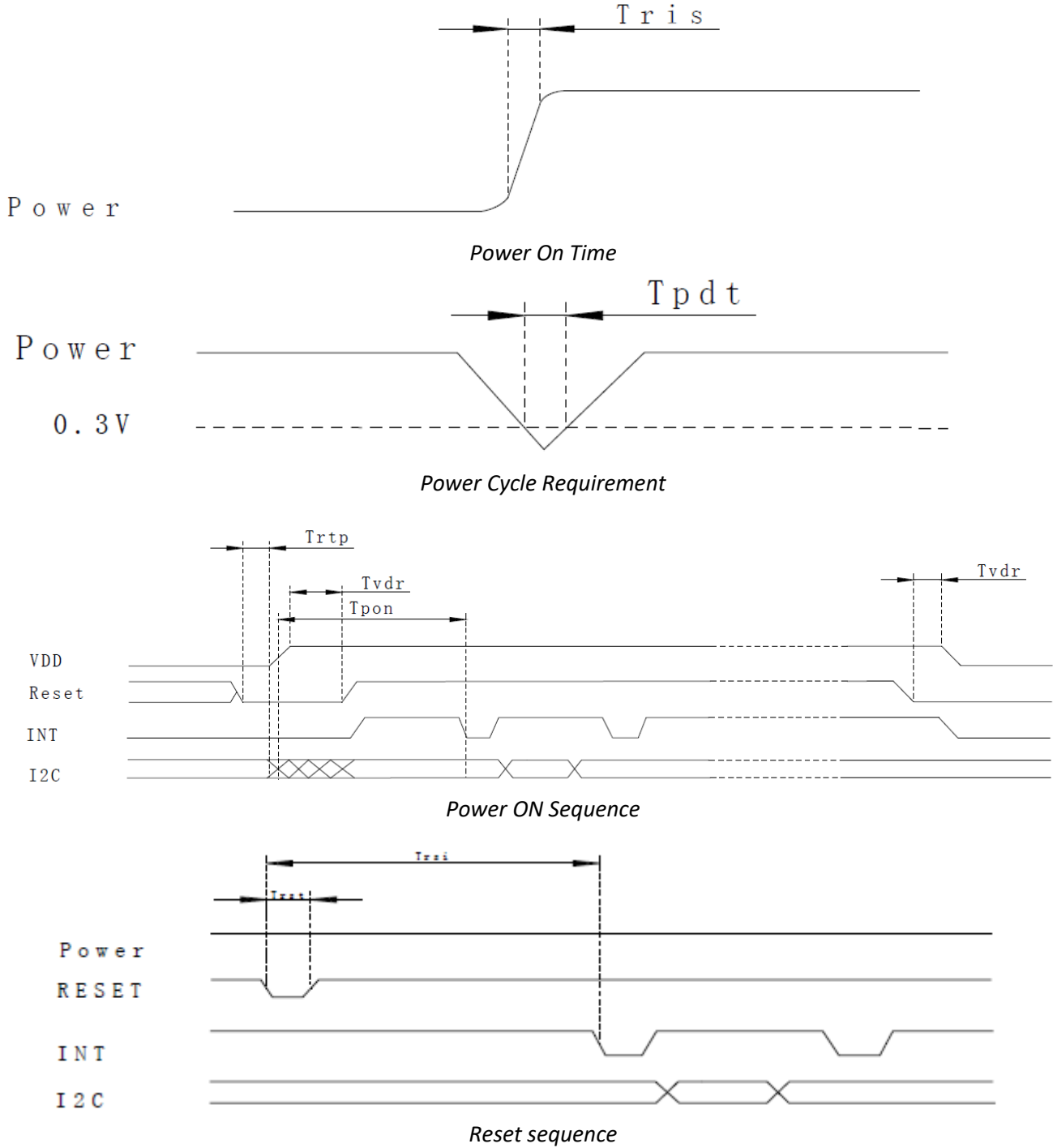

Parameter	Description	Min	Max	Unit
Tris	Rise time from 0.1V _{DD} to 0.9V _{DD}	-	5	ms
Tpd t	Time of the voltage of supply being below 0.3V	5	-	ms
Trtp	Time of resetting to be low before powering on	100	-	μs
Tpon	Time to start reporting after power on	-	200	ms
Tvdr*	Reset time after applying V _{DD}	1	-	ms
Trsi	Time to start reporting after reset	-	200	ms
Trst*	Reset Time	1	-	ms

*Note: If Reset is tied to V_{DD} data corruption can occur

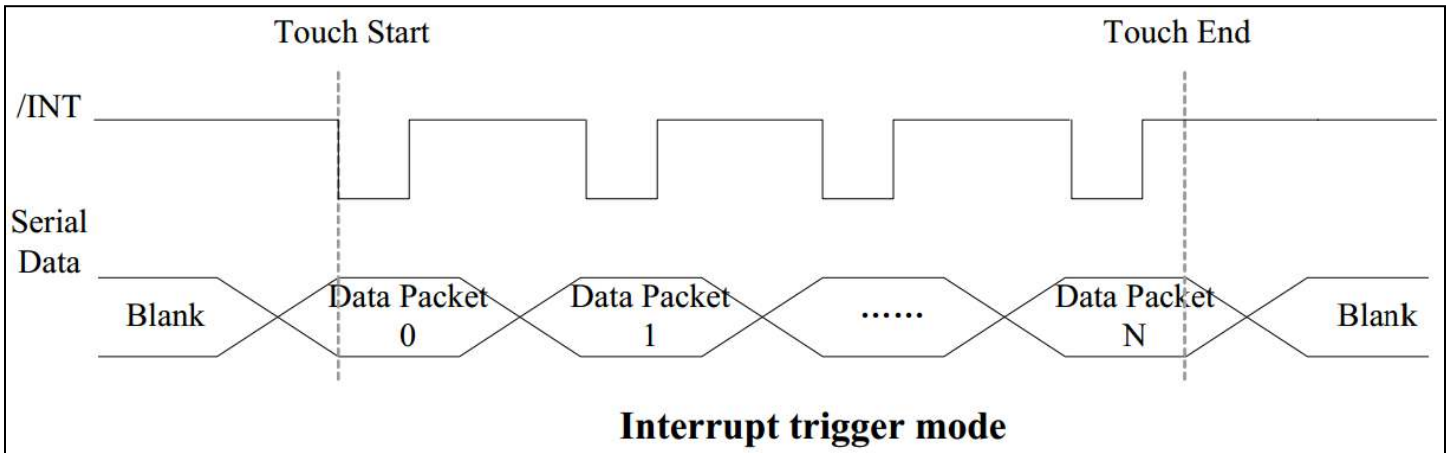

Sample code to read touch data:

```

i2c_start();
i2c_tx(0x70);           //Slave Address (Write)
i2c_tx(0x00);           //Start reading address
i2c_stop();

i2c_start();
i2c_tx(0x71);           //Slave Address (Read)
for(i=0x00;i<0x1F;i++)
{touchdata_buffer[i] = i2c_rx(1);}
i2c_stop();

```

Sample code to overwrite default register values:

```

i2c_start();
i2c_tx(0x70);           //Slave Address (Write)
i2c_tx(0xA4);           //ID_G_Mode
i2c_tx(0x01);           //Disable interrupt status to host
i2c_stop();

```

Quality Information

Test Item	Content of Test	Test Condition	Note
High Temperature storage	Endurance test applying the high storage temperature for a long time.	+80°C , 96 Hrs.	2
Low Temperature storage	Endurance test applying the low storage temperature for a long time.	-30°C , 96 Hrs.	1,2
High Temperature Operation	Endurance test applying the electric stress (voltage & current) and the high thermal stress for a long time.	+70°C , 96 Hrs.	2
Low Temperature Operation	Endurance test applying the electric stress (voltage & current) and the low thermal stress for a long time.	-20°C , 96 Hrs.	1,2
High Temperature / Humidity Operation	Endurance test applying the electric stress (voltage & current) and the high thermal with high humidity stress for a long time.	+60°C , 90% RH , 96 Hrs.	1,2
Thermal Shock resistance	Endurance test applying the electric stress (voltage & current) during a cycle of low and high thermal stress.	-20°C,30min -> 25°C,5min -> 70°C,30min -> 25°C,5min = 1 cycle, 10 cycles	-
Vibration test	Endurance test applying vibration to simulate transportation and use.	10-55Hz , 1.5mm amplitude. 2 hours. Each Direction X,Y,Z	3
Static electricity test	Endurance test applying electric static discharge.	Air: V _s =±8KV, Contact: V _s =±4KV 5 Times	-

Note 1: No condensation to be observed.

Note 2: Conducted after 4 hours of storage at 25°C, 0%RH.

Note 3: Test performed on product itself, not inside a container.