



Science.
Applied to Life.™



3M Separation and Purification Sciences

3M™ Zeta Plus™ Depth Filters

High Performance, Scalable,
Single-Use System

3M™ Zeta Plus™ Encapsulated System

The System of Choice for Single-Use Depth Filtration

High Performance Filter Media

The 3M™ Zeta Plus™ Encapsulated System utilizes the high performing Zeta Plus depth filter series media, including the single and dual layer.

- ▶ Positive charge is capable of reducing negatively charged DNA, endotoxins and other host cell proteins
- ▶ The 3M™ Zeta Plus™ dual layer media enhances the contaminant holding capacity of the filter media. This allows for larger particles to be trapped in the upstream zone of the more open filter media and smaller particles to be trapped in the downstream zone, reducing premature plugging and helping extend service life of the media.
- ▶ Can be used for post fermentation cell culture clarification or downstream impurity removal
- ▶ Can be employed independently or in conjunction with centrifugation or tangential flow filtration (TFF)
- ▶ Activated carbon and lipid removal media also available

3M™ Zeta Plus™ Depth Filter Quick Start Guide

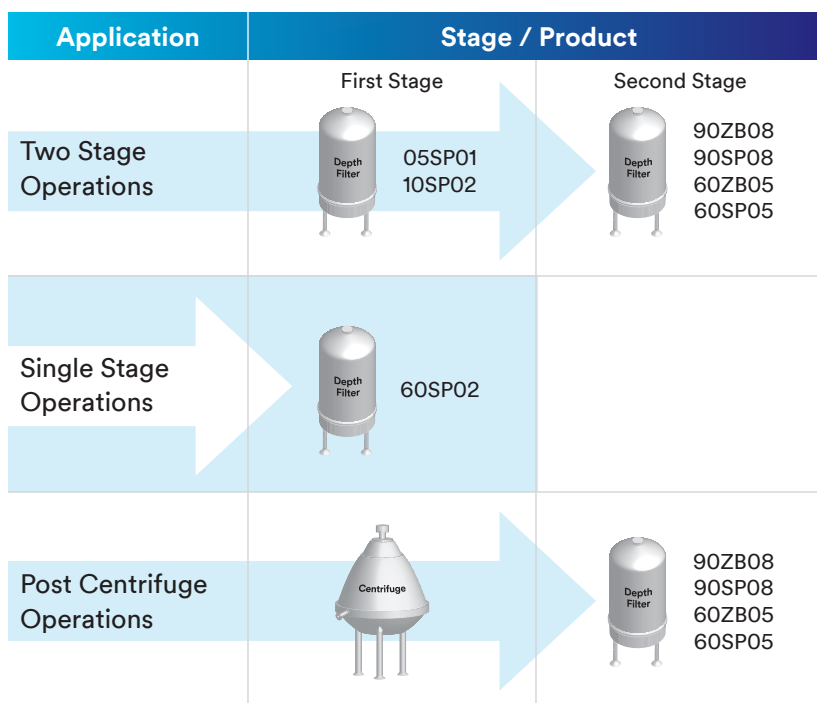

Media Series

SP Media	LA Media	ZB Media
Widest Range	Cleanest	Highly Charged
SP has the widest nominal pore size range relative to other 3M Zeta Plus media offerings, including a greater number of grades as well as grades with larger nominal pore sizes than LA or ZB media.	LA is the cleanest 3M Zeta Plus media family offered. 3M™ Zeta Plus™ LA series low aluminum (LA) filter media are designed to provide low levels of extractables, especially aluminum.	ZB media offers a higher charge level than SP or LA media, and offers single layer and dual layer grades with a smaller nominal pore size than either the SP media family or the LA media family.

Sizing Guide

Pore Size Options: 3M™ Zeta Plus™ SP, LA and ZB Media

Media Family				Application
Grades	SP	ZB	LA	
5	X			Primary
10	X			
30	X	X	X	
50			X	Secondary
60	X	X	X	
90	X	X	X	Centrate
120		X		

For reference only. Retention ratings may vary depending on application.

Features & Benefits

Capsule/Manifold Design

- Translucent plastic shell (standard capsules, polycarbonate shells)
 - ▶ Easy detection of the liquid level inside, providing real time monitoring of the filtration process.
- Fully encapsulated shell around solid core
 - ▶ Eliminates the need for a stainless steel housing and the cleaning step after filtration.
- Self guiding locking mechanism
 - ▶ Fast and reliable capsule-to-capsule connectivity.
- Lenticular style capsule design
 - ▶ Consistency between single-use and conventional depth filtration.



3M™ Zeta Plus™ Capsules:
Encapsulated Standard Capsule with Polycarbonate Shells

3M™ Zeta Plus™ Capsules: Encapsulated Capsule with Alkaline Resistant* Polyphenylene Oxide/Polystyrene



3M™ Zeta Plus™ Capsule Family



Self Guiding Locking Mechanism Enables Fast and Reliable Capsule-To-Capsule Connection

* Based on testing with 1M NaOH and 5% NaClO (Bleach).

3M™ Zeta Plus™ Filter Media



Model# 16EZB

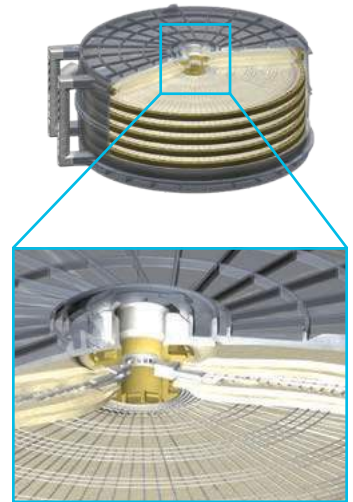

- ▶ Both single and dual layer Zeta Plus filter media are available.
- ▶ Excellent performance in throughput and filtration efficiency with proper media selection and sizing.
- ▶ The 3M™ Zeta Plus™ Encapsulated System is a single use depth filtration system
- ▶ The complete system is comprised of a holder, two manifolds and the desired number of capsules
- ▶ The polycarbonate capsules feature a translucent shell that allows for easy fluid level observation
- ▶ A self-guiding locking mechanism ensures fast and reliable connections between capsules

3M™ Zeta Plus™ Encapsulated System

The System of Choice for Single-Use Depth Filtration

Ergonomically Designed Large Filter Holders

Traditional depth filtration systems utilize lenticular style cartridge filters and a vertical filtration flow path to allow easy access to process liquids and efficient utilization of filter media. However, stacking cartridges from bottom to top can be cumbersome, and dismantling the spent cartridges is often labor intensive.

Features & Benefits

Ergonomically Designed Holder System

3M™ Encapsulated System Holder, Large (Model #16EZB): holder is pivoted between horizontal and vertical positions

- ▶ Enables loading and unloading at waist height.
- ▶ Central inlets and outlets minimize fluid spills during post use handling.
- ▶ Holder and capsule design allows the combination of multiple 3M Zeta Plus media types or even multiple 3M filtration products in a single holder.

Vertical flow path

- ▶ Reduced footprint during operation.



Recognizing the need for a depth filtration system that is fast, easy and clean, 3M designed filter holders (Model# 16EZB) that can be pivoted between the horizontal position for loading and unloading the capsules and manifolds, and the vertical position for filtration. Allowing loading and unloading at waist height eliminates the need for operators to lift capsules above their heads and reduces the risk of fluid spills when handling spent capsules. The use of the vertical flow path allows for full media utilization and a small system footprint during filtration.

3M™ Encapsulated System Holders, Small (Model# 16EZA)

The small holder is available for laboratory and pilot scale-up studies, in addition to low volume production filtration. The 1-high holder can accommodate from one to four 0.23 m² capsules, or one 1.6 m² (dual layer) or 2.5 m² (single layer) capsule. The 2-high holder can accommodate up to two 1.6 m² (dual layer) or 2.5 m² (single layer) capsules. The 3 high holder can accommodate up to three 1.6 m² (dual layer) or 2.5 m² (single layer) capsules. Either single stage or two-stage depth filtration can be performed within the same holder. The 1-high small holder has a built-in torque limiter that will signal the operator when the holder assembly is properly sealed. All small holders have been designed to be fully autoclavable for applications where that may be required.



3M™ Encapsulated System Holders, Large (Model# 16EZB)

The large holder can accommodate up seven 1.6 m² (dual layer) or 2.5 m² (single layer) capsules. This holder is best suited for use in small to large production scale purification processes. However, this holder can also accommodate a single 1.6 m² (dual layer) or 2.5 m² (single layer) capsule should choose to use it for scale up studies.



Two Stage Operations

For two stage purification operations a second pair of manifolds is required between each stage of multistage operations. Manifold and capsule materials should always be the same.

Figure 1. 3M™ Zeta Plus™ Encapsulated System

Innovative Capsule/Manifold Design

Two capsule configurations are available for use with the 3M™ Zeta Plus™ Encapsulated System.

- ▶ Single cell and multicell capsules are available
- ▶ Single cells have 0.23 m² of filtration media
- ▶ Multicells have 1.6 m² of dual layer media or 2.5 m² of single layer media
- ▶ Alkaline resistant capsules available
- ▶ Dual stage filtration can be performed in the same holder by using an additional set of manifolds

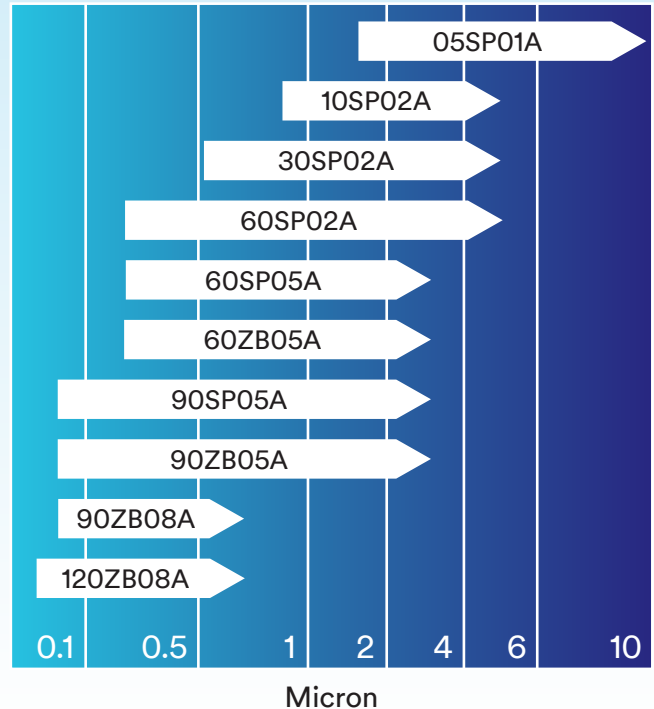

Figure 2. Nominal Retention Ratings for 3M™ Zeta Plus™ Dual Layer Grades

(For reference only. Retention ratings may vary depending on application.)

*Based on testing with 1M NaOH and 5% NaClO (Bleach).

Additional Formats Available

In addition to the 3M™ Zeta Plus™ Encapsulated system, cartridge and sheet options

Zeta Plus Cartridges:

- ▶ Produced in 8 inch, 12 inch and 16 inch sizes
- ▶ Multiple lenticle and construction configurations
- ▶ Dual Layer cartridges are available in SP, ZB and LA media families
- ▶ Stainless steel housings for each size available
- ▶ Uses the same media as encapsulated systems



Scalability

The 3M™ Zeta Plus™ Encapsulated System retains the lenticular filter design and vertical flow path that are characteristics of traditional depth filtration systems. A full range of 3M™ Zeta Plus™ capsules is available from benchtop to production scale, which allows for lab scale, pilot testing and scale-up with the same filtration media.

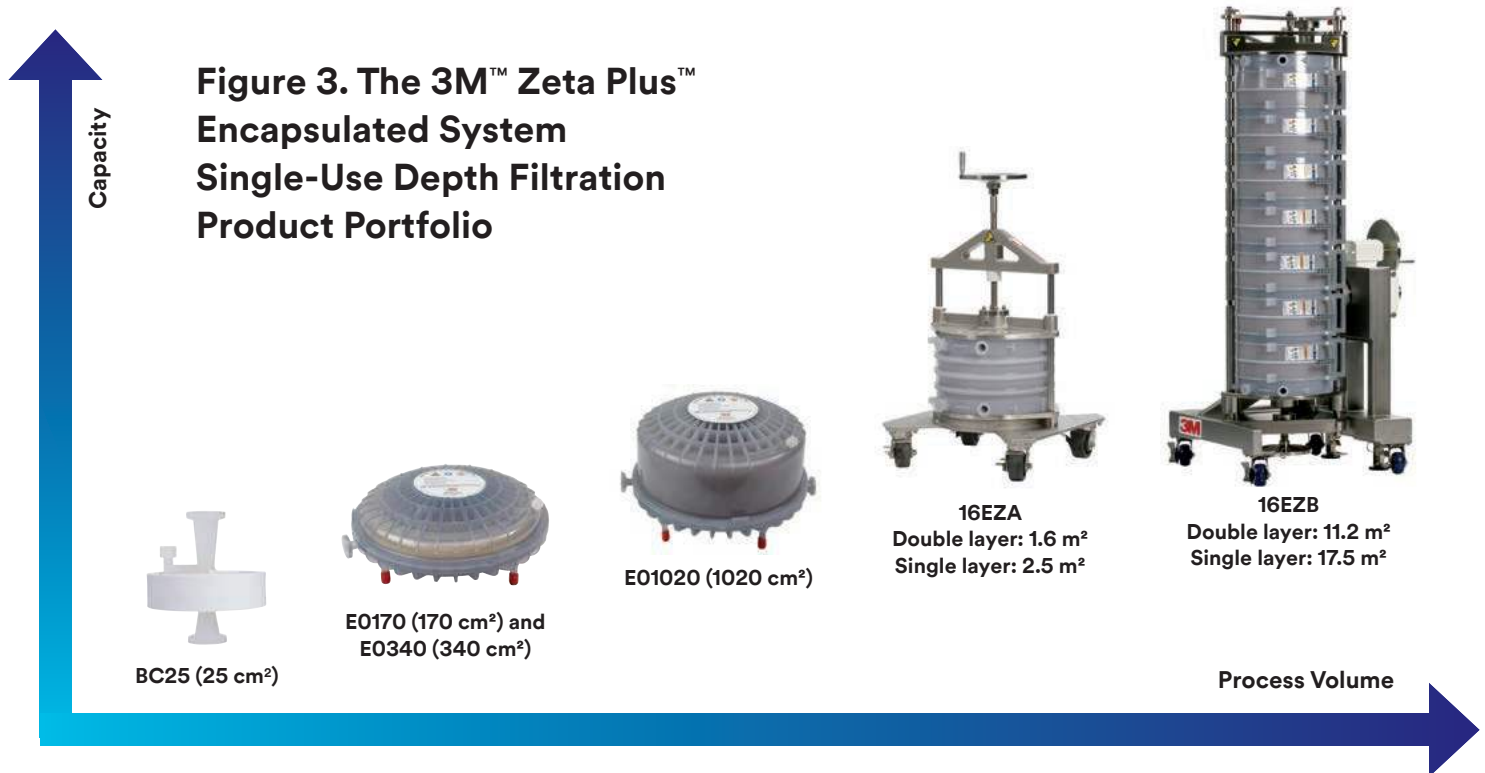

are also available in most media types and grades.

Zeta Plus Sheets:

- ▶ Available in SP, ZB and LA media families
- ▶ Activated carbon and lipid removal media available on request
- ▶ May be die cut to match specific requirements
- ▶ Designed for use with commercially available filter presses



Contact your local sales rep for additional information about these formats.

Table 2a. 3M™ Zeta Plus™ Laboratory Capsules: Filter Specifications

	BC25, Luer	BC25, Sanitary
Dimensions		
Single Layer (height by diameter)	6.5 cm × 7.6 cm (2.6 inches × 3 inches)	7.9 cm × 7.6 cm (3.1 inches × 3 inches)
Dual Layer (height by diameter)	6.9 cm × 7.6 cm (2.7 inches × 3 inches)	8.3 cm × 7.6 cm (3.3 inches × 3 inches)
Weight		
Dry - Single Layer	≈ 60 g	≈ 64 g
Dry - Dual Layer	≈ 69 g	≈ 75 g
Wet Post Blow-Down - Single Layer	≈ 70 g	≈ 75 g
Wet Post Blow-Down - Dual Layer	≈ 86 g	≈ 93 g
Materials of Construction		
Shells	Polypropylene	
Ring Seal (dual layer media)	Polypropylene	
Edge Seal Overmold	Glass Fiber Filled Polypropylene	
Luer Cap & Luer-barb Connector	Polypropylene	
Volume		
Capsule Fill Volume ¹ - Single Layer	≈ 17 mL	
Capsule Fill Volume ¹ - Dual Layer	≈ 25 mL	
Post Blow-Down Hold-up Volume ² - Single Layer	≈ 11 mL	
Post Blow-Down Hold-up Volume ² - Dual Layer	≈ 17 mL	
Miscellaneous		
Effective Filtration Area	25 cm ²	25 cm ²
Connector	Luer	Can accommodate both ½" and ¾" Sanitary Style

¹ Volume of liquid required to fill capsule (experimentally measured).

² Capsule Post blow-down hold-up volume. Estimated volume of residual preconditioning flush liquid after air/gas blow-down, using water as the flush fluid and calculated by post-blow-down weight and flush fluid density. Actual amount depends upon exact blow-down conditions, media type in capsule, the number of capsules in the system, the process fluid, and loading level of the capsule.

Laboratory Capsule Filter Schematics



BC-25 Sanitary Lab Capsule



BC-25 Luer Lab Capsule

Table 2b. 3M™ Zeta Plus™ Scale-Up Capsules: Filter Specifications

		170 cm ² Capsule	340 cm ² Capsule	1020 cm ² Capsule
Dimensions				
Height × Diameter		4.1" × 8.5" (10.3 cm × 21.6 cm)		6.0" × 8.5" (15.2 cm × 21.6 cm)
Weight				
Dry - Single Layer		1.0 kg (2.2 lb)	1.0 kg (2.2 lb)	1.4 kg (3.0 lb)
Dry - Dual Layer		1.0 kg (2.2 lb)	1.0 kg (2.3 lb)	1.6 kg (3.5 lbs)
Wet Post Blow-Down - Single Layer		1.1 kg (2.4 lb)	1.1 kg (2.5 lb)	1.8 kg (4.0 lb)
Wet Post Blow-Down - Double Layer		1.2 kg (2.6 lb)	1.3 kg (2.9 lb)	2.4 kg (5.2 lb)
Materials of Construction				
Capsule Shells		Polysulfone		
Separator, Spacer, Vent Cap		Polypropylene		
O-ring		Fluorocarbon		
Endcap & Edge Seals		Thermoplastic Elastomer		
Hold-up Volume				
Capsule Fill Volume ¹	Single Layer	≈ 0.67 L (≈ 1.5 gal)	≈ 0.69 L (≈ 1.5 gal)	≈ 1.7 L (≈ 3.7 gal)
	Dual Layer	≈ 0.63 L (≈ 1.4 gal)	≈ 0.65 L (≈ 1.4 gal)	≈ 1.6 L (≈ 3.5 gal)
Post Blow-Down Hold-up Volume ²	Single Layer	≈ 0.12 L (≈ 0.26 gal)	≈ 0.16 L (≈ 0.35 gal)	≈ 0.46 L (≈ 1.0 gal)
	Dual Layer	≈ 0.15 L (≈ 0.34 gal)	≈ 0.26 L (≈ 0.58 gal)	≈ 0.80 L (≈ 1.8 gal)
Miscellaneous				
Effective Filtration Area		170 cm ² (0.18 ft ²)	340 cm ² (0.37 ft ²)	1020 cm ² (1.10 ft ²)
Connector		1/2" Sanitary Style		

¹ Volume of liquid required to fill capsule (experimentally measured).

² Capsule Post blow-down hold-up volume. Estimated volume of residual preconditioning flush liquid after air/gas blow-down, using water as the flush fluid and calculated by post-blow-down weight and flush fluid density. Actual amount depends upon exact blow-down conditions, media type in capsule, the number of capsules in the system, the process fluid, and loading level of the capsule.

IMPORTANT NOTICE: Always operate the filter system within the maximum differential pressure of 2.4 bar (35 psig).

Scale-Up Capsule Filter Schematics

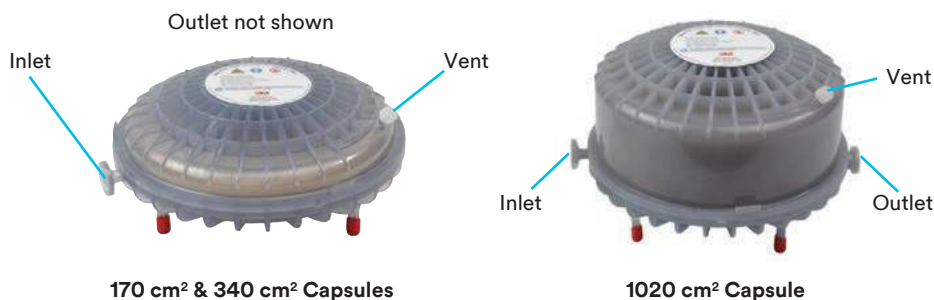

Table 2c. 3M™ Zeta Plus™ Production Capsules: Filter Specifications

	Configuration			
	Single Cell Capsule		Multi-Cell Capsule	
	Standard	Alkaline Resistant ¹	Standard	Alkaline Resistant ¹
Dimensions (Height × Diameter)	5.7 cm × 45.2 cm (2.2" × 17.8")		20.3 cm × 45.2 cm (8.0" × 17.8")	
Weight				
Dry	3.3 kg (7 lbs)	3.4 kg (8 lbs)	10.0 kg (22 lbs)	10.7 kg (24 lbs)
Wet (post Blow-Down)	4.4 kg (10 lbs)	4.8 kg (11 lbs)	19.3 kg (43 lbs)	19.7 kg (43 lbs)
Materials of Construction				
Filter Media	Filter aids, cellulose, binding resin		Filter aids, cellulose, binding resin	
Outer Shell	Polycarbonate	Polyphenylene oxide / Polystyrene	Polycarbonate	Polyphenylene oxide / Polystyrene
O-rings	Silicone		Silicone	
Separators, Spacers and Connectors	Polypropylene		Polypropylene	
Edge Seals	Thermoplastic Elastomer		Thermoplastic Elastomer	
Handles	N/A		Nylon	
Hold-up Volume				
Capsule Fill Volume ²	Single Layer	E16E01 & E16R01: ≈ 3.8 L (≈ 1.0 gal)		E16E11 & E16R11: ≈ 18.8 L (≈ 5.0 gal)
	Dual Layer	E16E01 & E16R01: ≈ 3.4 L (≈ 0.9 gal)		E16E07 & E16R07: ≈ 18.1 L (≈ 4.8 gal)
Post Blow-Down Hold-up Volume ³	Single Layer	E16E01 & E16R01: ≈ 0.7 L (≈ 0.2 gal)		E16E11 & E16R11: ≈ 7.5 L (≈ 2.0 gal)
	Dual Layer	E16E01 & E16R01: ≈ 1.3 L (≈ 0.4 gal)		E16E07 & E16R07: ≈ 9.0 L (≈ 2.4 gal)
Maximum Operating Line Pressure	3.4 bar (50 psig)		3.4 bar (50 psig)	
Maximum Differential Pressure				
Forward	2.4 bar (35 psid)		2.4 bar (35 psid)	
Effective Filtration Area	0.23 m ² (2.4 ft ²)		Double layer: 1.6 m ² (17.2 ft ²) Single layer: 2.5 m ² (27.0 ft ²)	

¹ Based on testing with 1M NaOH and 5% NaClO (Bleach).

² Volume of liquid required to fill capsule (experimentally measured).

³ Capsule Post blow-down hold-up volume. Estimated volume of residual preconditioning flush liquid after air/gas blow-down, using water as the flush fluid and calculated by post-blow-down weight and flush fluid density. Actual amount depends upon exact blow-down conditions, media type in capsule, the number of capsules in the system, the process fluid, and loading level of the capsule.

Single-Use Capsule Filter Schematic

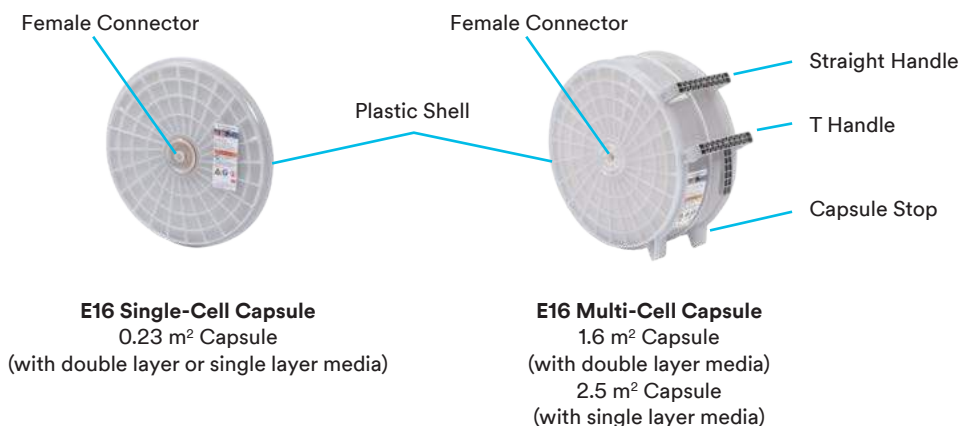

Table 2d. 3M™ Encapsulated System Manifold Specifications

	Configuration	
	Standard	Alkaline Resistant ¹
Dimensions (Height × Diameter)	5.2 cm × 45.2 cm (2.0" × 17.8")	
Connector	1.5" Sanitary Style	
Material	Polycarbonate	Polyphenylene oxide / Polystyrene
Weight	4.4 kg (9.6 lbs)	4.7 kg (10.4 lbs)
Hold up Volume Per Set	< 250 mL (<0.07 gal)	

Single-Use Manifold Filter Schematic

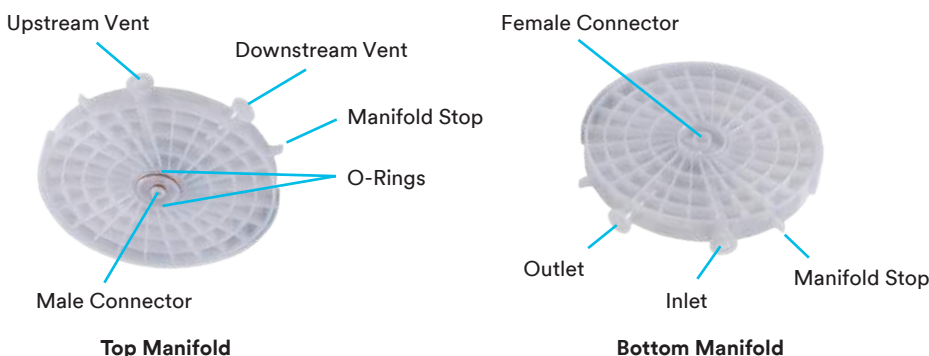

Table 3. 3M™ Encapsulated System Holder Specifications

	Holder Model	
	Small Holder (Model# 16EZA)	Large Holder (Model# 16EZB)
Maximum Operating Pressure	5.2 cm × 45.2 cm (2.0" × 17.8")	
Materials of Construction		
Frame	304 Stainless Steel	304 Stainless Steel
End Plates	304 Stainless Steel	304 Stainless Steel
Support Rods	440 Stainless Steel	316 Stainless Steel
Stand	304 Stainless Steel	304 Stainless Steel
Hand Wheels	300 Series Stainless Steel	300 Series Stainless Steel
Gear Box	N/A	Epoxy Coated Cast Iron Cover Shrouded in 304 Stainless Steel
Locking Bar	N/A	304 Stainless Steel
Casters	Stainless Steel	Stainless Steel
Wheels	Phenolic	Polyurethane
Material		
Standard	Mechanical Polish Finish (4552601)	Mechanical Polish Finish (6123502)
Special	Electropolish Finish (4552602)	N/A

Table 4. 3M™ Encapsulated System Holder Capacity

Model	Single Stage		Two Stage	
	E16E01 Capsule	E16E07/E16E11 Capsule	E16E01 Capsule	E16E07/E16E11 Capsule
16EZA	4	1	2	N/A
16EZB	N/A	7	N/A	6

Table 4a. 3M™ Single Cell Capsule Capacities

Holder	Single Cell Capsules (E16E01, E16R01, BV800)	
	Single Stage Filtration (one set of manifolds)	Two Stage Filtration* (two sets of manifolds)
Small, 1-high (Part #4552601)	up to 4	2 to 3
Small, 2-high (Part #4552603)	up to 9	5 to 8
Small, 3-high (Part #4552604)	up to 11	6 to 9
Large (Part #6123502)	4 to 26	2 to 23

Table 4b. 3M™ Multi-Cell Capsule Capacities

Holder	Multi-Cell Capsules (E16E07, E16R07, E16E11, E16R11, BV5600)	
	Single Stage Filtration (one set of manifolds)	Two Stage Filtration* (two sets of manifolds)
Small, 1-high (Part #4552601)	1	n/a
Small, 2-high (Part #4552603)	2	2
Small, 3-high (Part #4552604)	3	2
Large (Part #6123502)	up to 7	2 to 6

*Number of 3M production capsules which will fit in a 3M holder along with two sets of 3M manifolds. For example, 2 single cell production capsules in the first stage followed by 1 single cell production capsule in the second stage meets the maximum of 3 single cell production capsules for Part Number 4552601.

Figure 9. Small Holder Family (Model# 16EZA) Dimensions

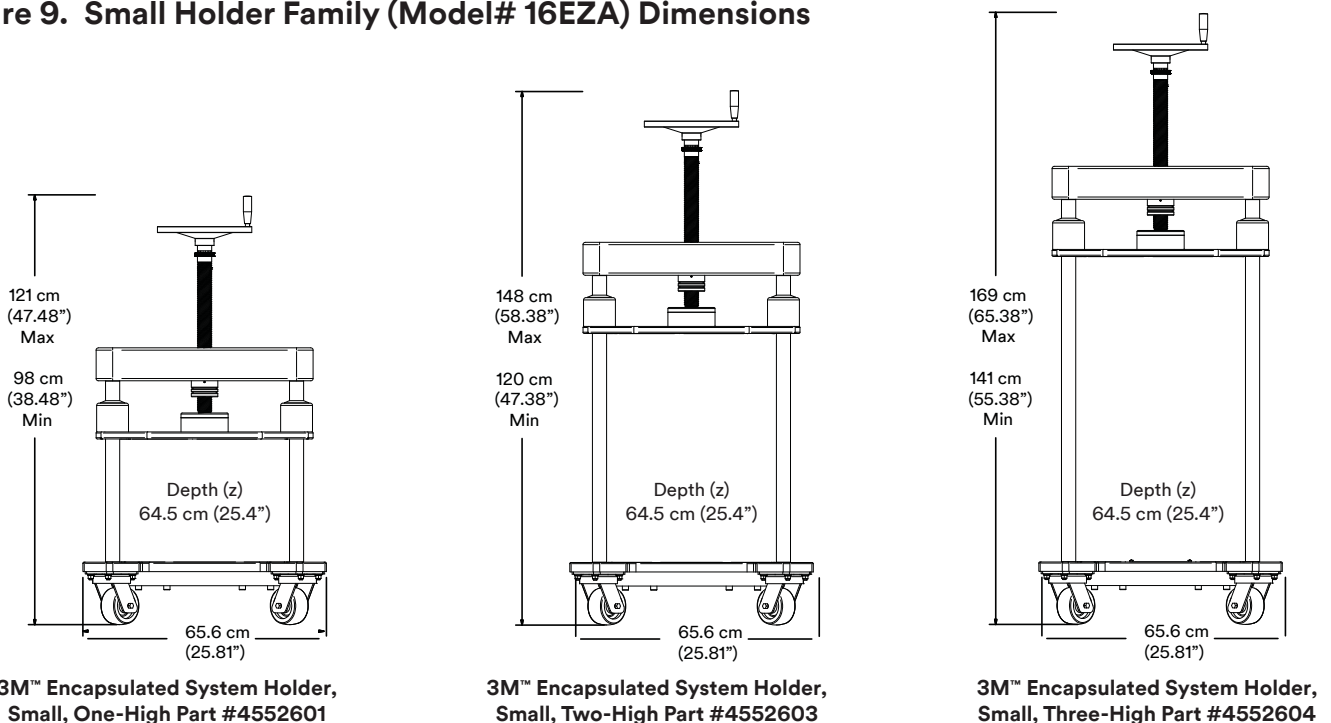
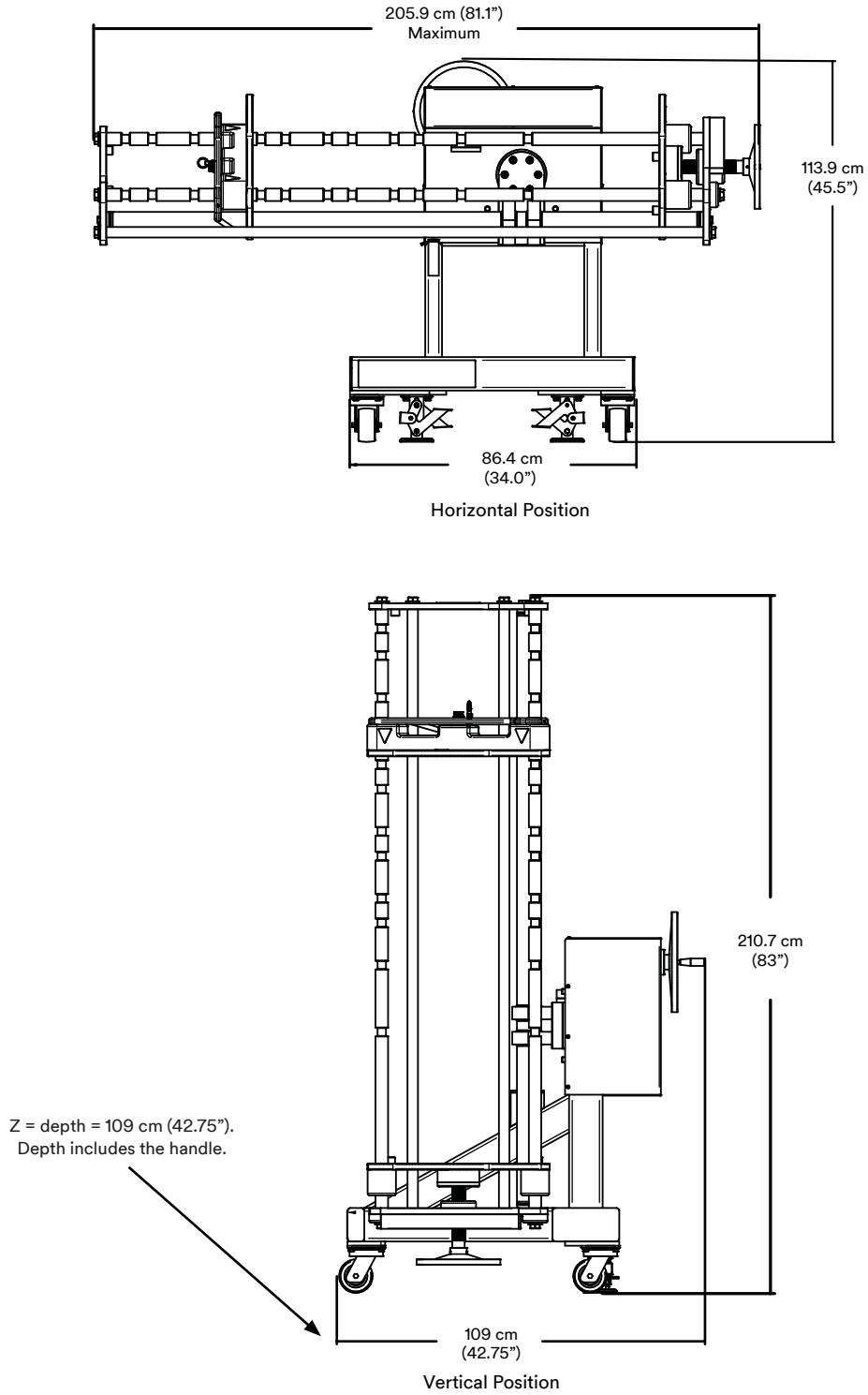

Figure 10. Large Holder (Model# 16EZB) Dimensions



3M™ Encapsulated System Holder, Large, Part #6123502

Capsule Ordering Guide

Capsule Product Naming Convention

E16 E 11 A 30 SP 01A

Diameter	Configuration	Number of Cells	Gasket Material	Grade	Media	Second Layer
16" Production	E - Standard R - Alkaline Resistant	1, 7 or 11 Cells 1 or 11 = Single 1 or 7 = Dual	A-Silicone	05, 10, 30, 50, 60, 90 are available for SP	SP, ZB, LA, DELI or DELP	01A, 02A, 03A, 05A indicate grade of second layer

Capsule Filter Ordering Information - Double Layer (U.S. Customers)

Catalog Number	Configuration	Number of Cells	Gasket Material	Grade			
E16	E - Standard R - Alkaline Resistant*	01 - 1 Cell 07 - 7 Cell	A-Silicone	05SP01A 10SP02A 30SP02A 30SP03A 60SP01A	60SP02A 60SP03A 60SP05A 90SP05A 90SP08A 60LA05A 90LA05A 90LA08A	120ZB05A 120ZB08A 120ZB10A 60ZB05A 90ZB05A 90ZB08A	DELP08A

Capsule Filter Ordering Information - Single Layer (U.S. Customers)

Catalog Number	Configuration	Number of Cells	Gasket Material	Grade		
E16	E - Standard R - Alkaline Resistant*	01 - 1 Cell 11 - 11 Cell	A-Silicone	30LA 60LA 90LA	10SP 30SP 50SP 60SP 90SP	30ZB 60ZB 90ZB 120ZB DELP

Manifold Ordering Information

Manifold Part	3M PI Part Number	3M ID
Manifold Set (Standard)	6128901	70020256221
Manifold Set (Alkaline Resistant*)	6129001	70020262369

Filter Holder Ordering Information

Model Name	3M Catalog ID (U.S. Customers)	Description	3M ID
16EZA	4552601	3M™ Encapsulated System Holder, Small, One-High	70020310846
	4552603	3M™ Encapsulated System Holder, Small, Two-High	70020310861
	4552604	3M™ Encapsulated System Holder, Small, Three-High	70020310879
16EZB	6123502	3M™ Encapsulated System Holder, Large	70020252899

Scale-Up Capsules - Dual Layer

3M Catalog ID (U.S. Customers)	EFA cm ²	Material Code	Grade		
E	0170 0340 1020	FSA	05SP01A 10SP02A 30SP02A 30SP03A 60SP01A 60SP02A 60SP03A 60SP05A 90SP05A 90SP08A	60LA05A 90LA05A 90LA08A 60ZB05A 90ZB05A 90ZB08A 120ZB05A 120ZB08A 120ZB10A	DELI08A DELP08A

Scale-Up Capsules - Single Layer

3M Catalog ID (U.S. Customers)	EFA cm ²	Material Code	Grade		
E	0170 0340 1020	FSA	05SP 10SP 30SP 50SP 60SP 90SP	30LA 50LA 60LA 90LA	30ZB 60ZB 90ZB 120ZB DELI DELP

*Based on testing with 1M NaOH and 5% NaClO (Bleach). See Chemical Compatibility Guide (70-0202-2023-5/LITPHG03) for more information.



Intended Use: 3M™ Zeta Plus™ single-use filter products are intended for use in biopharmaceutical processing applications of aqueous and chemical based pharmaceuticals (drugs) and vaccines in accordance with the product instructions and specifications, and cGMP requirements, where applicable. Since there are many factors that can affect a product's use, the customer and user remain responsible for determining whether the 3M product is suitable and appropriate for the user's specific application, including user conducting an appropriate risk assessment and evaluating the 3M product in user's application.

Restricted Use: 3M advises against the use of these 3M products in any application other than the stated intended use(s), since other applications have not been evaluated by 3M and may result in an unsafe or unintended condition. Do not use in any manner whereby the 3M product, or any leachable from the 3M product, may become part of or remains in a medical device that is regulated by any agency, and/or globally exemplary agencies, including but not limited to: a) FDA, b) European Medical Device Directive (MDD), c) Japan Pharmaceuticals and Medical Devices Agency (PMDA) or in applications involving permanent implantation into the body; Life-sustaining medical applications; Applications requiring food contact compliance.

Product Selection and Use: Many factors beyond 3M's control and uniquely within user's knowledge and control can affect the use and performance of a 3M product in a particular application. As a result, end-user is solely responsible for evaluating the product and determining whether it is appropriate and suitable for end-user's application, including completing a risk assessment that considers the product leachable characteristics and its impact on drug safety conducting a workplace hazard assessment and reviewing all applicable regulations and standards (e.g., OSHA, ANSI, etc.). Failure to properly evaluate, select, and use a 3M product and appropriate safety products, or to meet all applicable safety regulations, may result in injury, sickness, death, and/or harm to property.

Warranty, Limited Remedy, and Disclaimer: Unless a different warranty is specifically stated on the applicable 3M product packaging or product literature (in which case such warranty governs), 3M warrants that each 3M product meets the applicable 3M product specification at the time 3M ships the product. 3M MAKES NO OTHER WARRANTIES OR CONDITIONS, EXPRESS OR IMPLIED, INCLUDING, BUT NOT LIMITED TO, ANY IMPLIED WARRANTY OR CONDITION OF MERCHANTABILITY, FITNESS FOR A PARTICULAR PURPOSE, OR ARISING OUT OF A COURSE OF DEALING, CUSTOM, OR USAGE OF TRADE. If a 3M product does not conform to this warranty, then the sole and exclusive remedy is, at 3M's option, replacement of the 3M product or refund of the purchase price.

Limitation of Liability: Except for the limited remedy stated above, and except to the extent prohibited by law, 3M will not be liable for any loss or damage arising from or related to the 3M product, whether direct, indirect, special, incidental, or consequential (including, but not limited to, lost profits or business opportunity), regardless of the legal or equitable theory asserted, including, but not limited to, warranty, contract, negligence, or strict liability.



3M Separation and Purification Sciences Division

400 Research Parkway
Meriden, CT 06450 USA

Phone: 1-800-243-6894
1-203-237-5541

Web: www.3M.com/bioprocessing

Please recycle. Printed in U.S.A. © 3M 2019.
3M and Zeta Plus are trademarks of 3M Company.
All rights reserved. 70-0202-3967-2 Rev 12/2019