

PART NUMBER	REV	FIRST USED	POWER UNIT	FEED TYPE	DESCRIPTION
1855189-1	D	122500-1	LEADMAKER	POST FEED	CUTS CARRIER
1855189-2	D	565435-5	BENCH MODEL K	PRE FEED	CUTS CARRIER
1855189-3	D	354500-1	BENCH MODEL G	PRE FEED	CUTS CARRIER
1855189-6	D	122500-1	LEADMAKER	POST FEED	CONTINUOUS CARRIER
7-1855189-7	A	-	-	-	SPARE PARTS

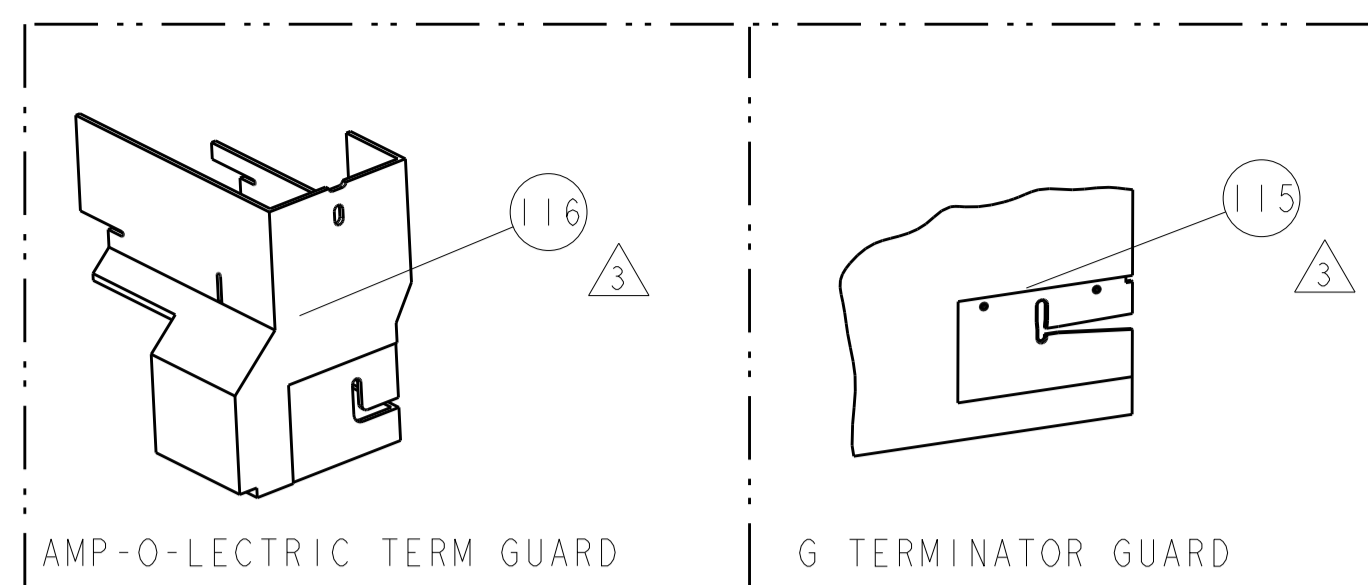

AMP PN		MOLEX PN		MOLEX TERMINAL - AMP CRIMP SPECS		REF SETTING
1572738-1		33001-0004		CRIMP HEIGHT	WIRE SIZE	B4
1642303-1		33012-0002		1.35±0.05mm [.053±.002]	16AWG	C5
1572738-2		33001-2004		1.20±0.05mm [.047±.002]	1mm2	D1
-		-		1.10±0.05mm [.043±.002]	18AWG or 0.75mm2	D4
-		-		1.05±.05mm [.041±.002]	20AWG	
CRIMP	SIZE	TYPE	RANGE			
-	1.91mm [.075]	F	20-16 AWG			
WIRE	INSUL	FEED	APPLICATOR INSTRUCTIONS			
-	2.54mm [.100]	0	408-8040 & 408-8490			
WIRE STRIP LENGTH		TERM APPL SPEC	SET UP GAGE			
5.0 - 5.8mm		NONE	458637-1			

LOC	DIST	REVISIONS					
A	66	P	LYN	DESCRIPTION	DATE	OWN	APVD
		D		ECR-14-004629	27MAR2014	RK	GB

- △ RECOMMENDED SPARE PARTS
- △ GREASE LIGHTLY
- △ GUARD MUST BE IN PLACE WHEN OPERATING APPLICATOR IN A BENCH MACHINE

**\* WARNING**  
ON INSTALLATION, SET WIRE DISC TO LARGEST WIRE SIZE SETTING. USE OF SETTINGS BELOW MIN. REQUIRED CRIMP HEIGHT SETTING WILL CAUSE DAMAGE TO CRIMP TOOLING.

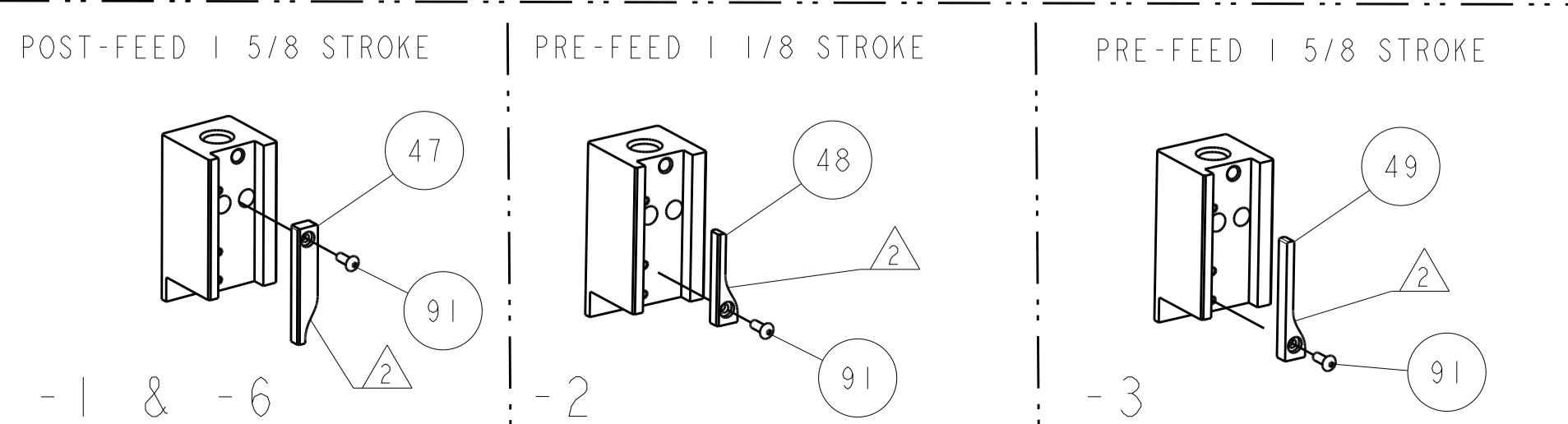
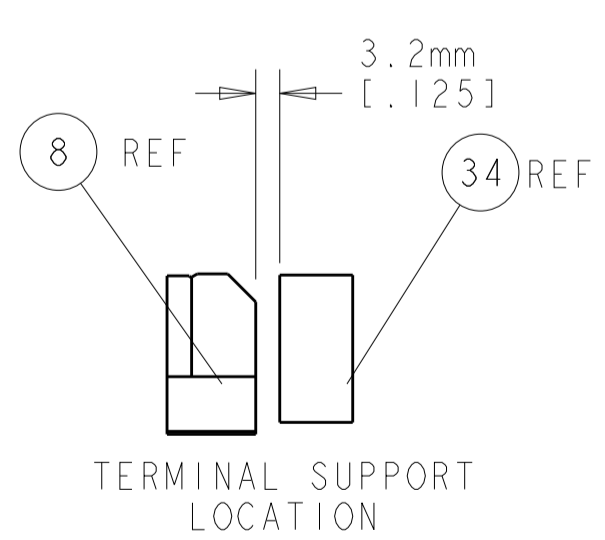
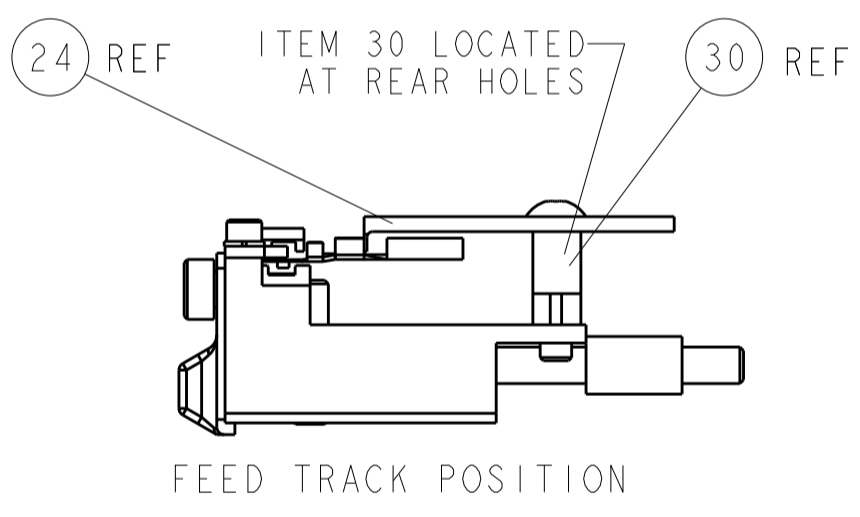
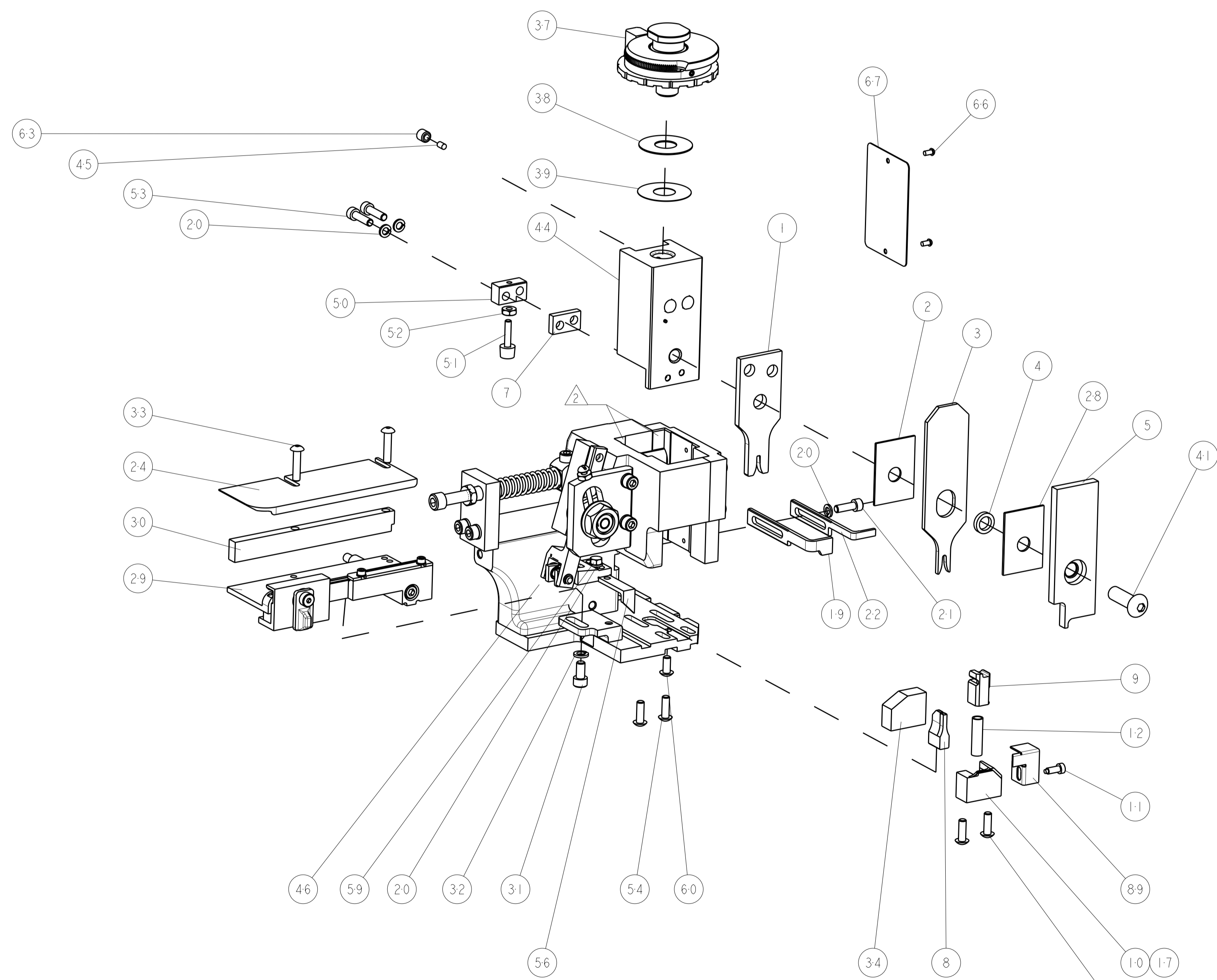

QTY	REF	DESCRIPTION	ITEM NO
1		455749-1 GUARD WINDOW	116
1		679532-1 INSERT, GUARD	115
1		1-21002-7 SCR, BTN SKT HD CAP 6-32 X .375	91
1		318563-1 GUARD, FRONT CHIP	89
1		4088040 SF APPL INST 408-8040	72
1		217238-1 GENERAL INSTRUCTION PKG	71
1		461264-5 PLATE, IDENTIFICATION	67
2		21017-2 SCREW, DRIVE	66
1		21009-2 SCR, SET, SELF LOCKING 1/4-20 X .250	63
1		22733-8 SCR, BHSC, SELF-LOCKING, 8-32 X .375	60
1		2-22603-0 SCR, HEX HD CAP 8-32 X .312	59
1		458537-2 PAWL, FEED	56
4		2-21002-2 SCR, BTN SKT HD CAP 8-32 X .500	54
2		2-21000-8 SCR, SKT HD CAP 8-32 X .625	53
1		21018-5 NUT, HEX, REG 6-32	52
1		811242-2 BUMPER, HOLD DOWN	51
1		690753-1 SPACER, TONKER	50
1		690602-6 CAM, PRE FEED, 1 5/8	49
1		690602-5 CAM, PRE FEED, 1 1/8	48
1		690501-4 CAM, POST-FEED 1 5/8	47
1		459456-1 APPL. BASIC SUB ASSY (SIDE WISE MOCA)	46
1		690191-1 PLUG, NYLON	45
1		455673-1 RAM, SIDE FEED	44
1		7-21002-9 SCR, BTN SKT HD CAP 5/16-24 X 1.00	41
1		690125-1 SHIM SUB-ASSY	39
1		1-469367-2 SHIM	38
1		879103-3 FINE ADJUST HEAD ASSEMBLY	37
1		690786-1 TERMINAL SUPPORT	34
2		2-21002-4 SCR, BTN SKT HD CAP 8-32 X .750	33
1		21024-5 WASHER, SPRG LOCK, REG NO 10	32
1		3-21000-4 SCR, SKT HD CAP 10-32 X .375	31
1		1-1320908-5 SPACER, STRIP GUIDE	30
1		1633091-5 ASSEMBLY, STRIP GUIDE	29
1		1-455888-0 SPACER, CRIMPER	28
1		1320928-3 STRIP GUIDE	24
1		690472-2 STRIPPER	22
1		2-21000-7 SCR, SKT HD CAP 8-32 X .500	21
4		21024-4 WASHER, SPRG LOCK, REG NO 8	20
1		691353-1 STRIPPER	19
1		679625-1 SHEAR HOLDER, FRONT (NO CUT)	17
1		3-22280-3 SPRING, COMPRESSION	12
1		690461-1 STOP, SHEAR	11
1		690459-1 SHEAR HOLDER, FRONT	10
1		454276-1 FLOATING SHEAR, FRONT	9
1		9-1633116-7 ANVIL, COMBINATION	8
1		6-240641-9 SPACER	7
1		1-455889-4 DEPRESSOR, SHEAR	5
1		238011-4 BLOCK, CRIMPER SPACER	4
1		9-456135-6 CRIMPER, INSULATION 0 PREMIUM	3
1		455888-9 SPACER, CRIMPER	2
1		8-568176-0 CRIMPER, WIRE	1

QTY	REF	DESCRIPTION	ITEM NO					
-77	-6	-3	-2	-1	U/M	PART NO	DESCRIPTION	ITEM NO