

BCD-TO-DECIMAL DECODER

**MC5442 • MC7442**  
**MC9352 • MC8352**

EXCESS THREE-TO-DECIMAL DECODER

**MC5443 • MC7443**  
**MC9353 • MC8353**

EXCESS THREE GRAY-TO-DECIMAL DECODER

**MC5444 • MC7444**  
**MC9354 • MC8354**

Add Suffix L for 16-Pin dual in-line ceramic package (Case 620).  
 Suffix P for 16-Pin dual in-line plastic package (Case 648).

- Input Loading Factor = 1
- Output Loading Factor = 10
- Total Power Dissipation = 140 mW typ/pkg
- Propagation Delay Time:
  - 2 Logic Levels = 22 ns typ
  - 3 Logic Levels = 23 ns typ
- DC Noise Margin = 1.0 V typ



2  
 4475  
 004475  
 ORIG  
 not

These devices decode four-bit BCD, Excess 3, or Excess 3 Gray inputs to select one-of-ten outputs. The selected output is in the logic "0" state, while all other outputs are in the logic "1" state. Full decoding of all valid input logic ensures that outputs remain off for any invalid input condition.

These devices are useful in memory selection, industrial control, and data routing applications.

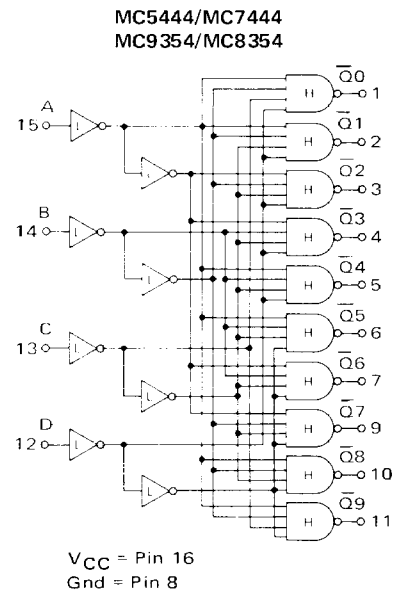
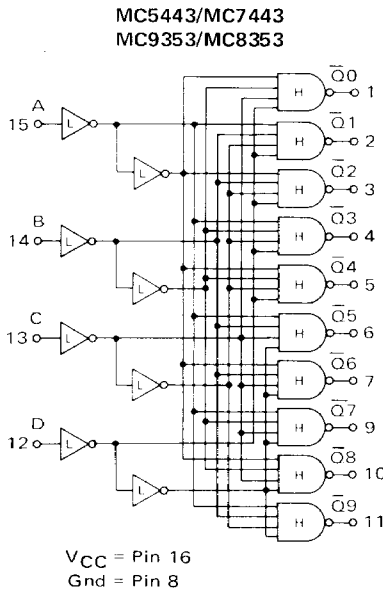
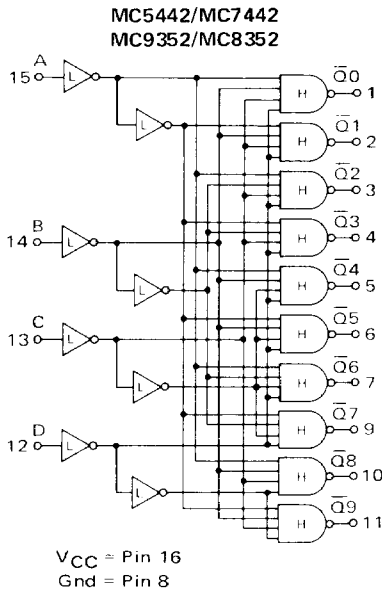

These decoders are constructed using low-level inverters and high-level NAND gates interconnected as shown by the logic diagrams. The inverter and gate schematics appear on the next page of this data sheet.

MC5442/MC7442 MC9352/MC8352 BCD INPUT				MC5443/MC7443 MC9353/MC8353 EXCESS 3 INPUT				MC5444/MC7444 MC9354/MC8354 EXCESS 3 GRAY INPUT				ALL TYPES DECIMAL OUTPUT									
D	C	B	A	D	C	B	A	D	C	B	A	9	8	7	6	5	4	3	2	1	0
0	0	0	0	0	0	1	1	0	0	1	0	1	1	1	1	1	1	1	1	1	0
0	0	0	1	0	1	0	0	0	1	1	0	1	1	1	1	1	1	1	1	0	1
0	0	1	0	0	1	0	1	0	1	1	1	1	1	1	1	1	1	1	0	1	1
0	0	1	1	0	1	1	0	0	1	0	1	1	1	1	1	1	1	0	1	1	1
0	1	0	0	1	0	0	0	1	1	0	0	1	1	1	1	0	1	1	1	1	1
0	1	0	1	1	0	0	1	1	1	0	1	1	1	1	0	1	1	1	1	1	1
0	1	1	0	1	0	1	0	1	1	1	1	1	1	0	1	1	1	1	1	1	1
0	1	1	1	1	0	1	0	1	1	1	1	1	1	0	1	1	1	1	1	1	1
1	0	0	0	1	1	0	0	1	0	1	0	1	0	1	1	1	1	1	1	1	1
1	0	0	1	1	1	0	1	1	0	1	1	1	1	1	1	1	1	1	1	1	1
1	0	1	0	1	1	0	1	1	0	1	0	1	1	1	1	1	1	1	1	1	1
1	0	1	1	1	1	1	0	1	0	0	1	1	1	1	1	1	1	1	1	1	1
1	1	0	0	1	1	1	1	1	0	0	0	1	1	1	1	1	1	1	1	1	1
1	1	0	1	0	0	0	0	0	0	0	0	1	1	1	1	1	1	1	1	1	1
1	1	1	0	0	0	0	1	0	0	0	1	1	1	1	1	1	1	1	1	1	1
1	1	1	1	0	0	1	0	0	0	1	1	1	1	1	1	1	1	1	1	1	1

CIRCUIT SCHEMATICS

LOW LEVEL INVERTER

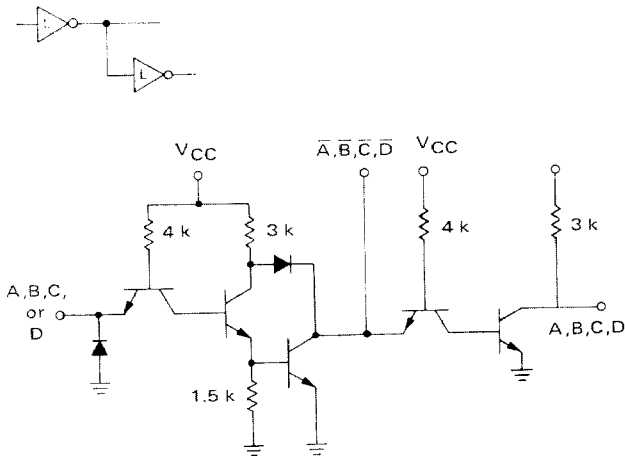

HIGH-LEVEL "NAND" GATE

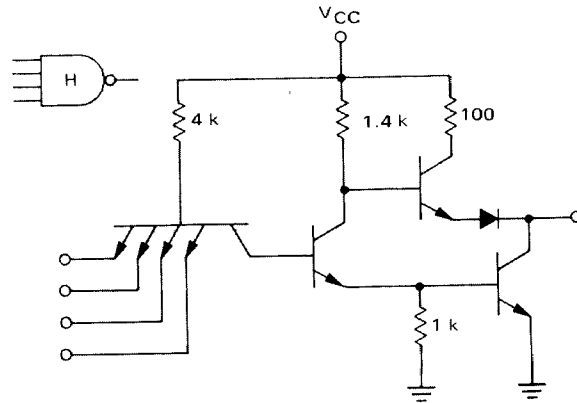

MC5442/MC7442, MC9352/MC8352

ELECTRICAL CHARACTERISTICS

Test procedures are shown for only one input and one output. Test other inputs and outputs in the same manner according to the truth table. Additionally, test all input-output combinations according to the truth table.

MC5442, MC9352  
 MC7442, MC8352

		TEST CURRENT/VOLTAGE VALUES (All Temperatures)																	
		mA		Volts															
		I <sub>OL</sub>	I <sub>OH</sub>	V <sub>IL</sub>	V <sub>IH</sub>	V <sub>ILT</sub>	V <sub>IHT</sub>	BV <sub>in</sub>	V <sub>CC</sub>	V <sub>CCCL</sub>	V <sub>CCCH</sub>								
		16	-0.4	0.4	2.4	0.8	2.0	5.5	5.0	4.5	5.5								
		16	-0.4	0.4	2.4	0.8	2.0	5.5	5.0	4.75	5.25								
		TEST CURRENT/VOLTAGE APPLIED TO PINS LISTED BELOW:																	
Characteristics	Symbol	Pin Under Test	MC5442/MC9352 Test Limits -55 to +125°C			MC7442/MC8352 Test Limits 0 to +75°C			I <sub>OL</sub>	I <sub>OH</sub>	V <sub>IL</sub>	V <sub>IH</sub>	V <sub>ILT</sub>	V <sub>IHT</sub>	BV <sub>in</sub>	V <sub>CC</sub>	V <sub>CCCL</sub>	V <sub>CCCH</sub>	Gnd
<b>Input</b>																			
Forward Current	I <sub>IL</sub>	12	-	-1.6	mAdc	-	-1.6	mAdc	-	-	12	-	-	-	-	-	-	16	8
Leakage Current	I <sub>IH</sub>	12	-	40	μAdc	-	40	μAdc	-	-	12	-	-	-	-	-	-	16	8
Breakdown Current	I <sub>in</sub>	12	-	1.0	mAdc	-	1.0	mAdc	-	-	-	-	-	-	12	-	-	16	8
<b>Output</b>																			
Output Voltage	V <sub>OL</sub>	1	-	0.4	Vdc	-	0.4	Vdc	1	-	-	-	12,13,14,15	-	-	-	16	-	8
	V <sub>OH</sub>	1	2.4	-	Vdc	2.4	-	Vdc	-	1	-	-	-	12,13,14,15	-	-	16	-	8
Short-Circuit Current	I <sub>OS</sub> <sup>†</sup>	1	-20	-55	mAdc	-18	-55	mAdc	-	-	-	-	-	-	-	-	12,13,14,15	16	1.8
<b>Power Requirements (Total Device)</b>																			
Power Supply Drain	I <sub>CC</sub>	16	-	41	mAdc	-	56	mAdc	-	-	-	-	-	-	-	-	-	16	8,12,13,14,15
<b>Switching Parameters*</b>																			
Two Logic Levels Turn-On Delay	t <sub>PHL2</sub>	15,1	10*	30*	ns	10*	30*	ns	15	1	-	-	-	-	-	-	16	-	8,12,13,14
Turn-Off Delay	t <sub>PLH2</sub>	15,1	10*	25*	ns	10*	25*	ns	15	1	-	-	-	-	-	-	16	-	8,12,13,14
Three Logic Levels Turn-On Delay	t <sub>PHL3</sub>	15,2	-	35	ns	-	35	ns	15	2	-	-	-	-	-	-	16	-	8,12,13,14
Turn-Off Delay	t <sub>PLH3</sub>	15,2	-	35*	ns	-	35*	ns	15	2	-	-	-	-	-	-	16	-	8,12,13,14

\*Tested only at 25°C  
 †Only one output should be shorted at a time.

### SWITCHING TIME TEST CIRCUIT AND VOLTAGE WAVEFORMS

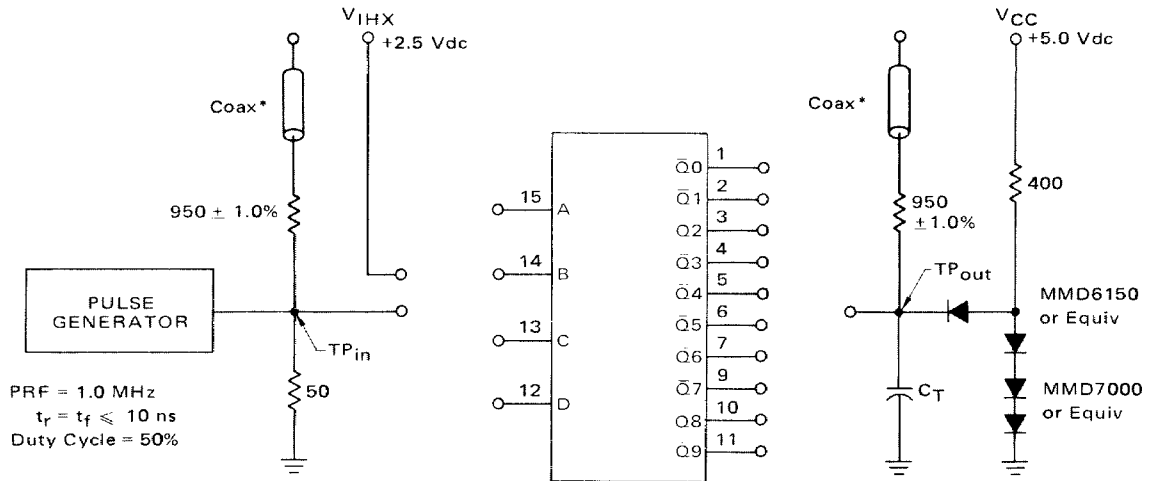

$C_T = 15$  pF = total parasitic capacitance, which includes probe, wiring, and load capacitance.

\*The coax delays from input to scope and output to scope must be matched. The scope must be terminated in 50-ohm impedance. The 950-ohm resistor and the scope termination impedance constitute a 20:1 attenuator probe.

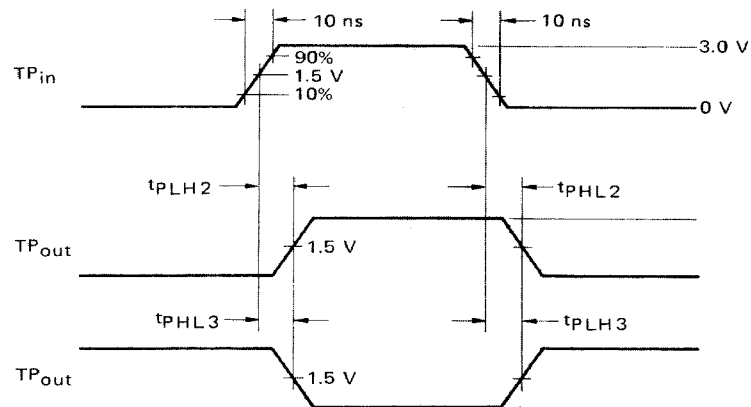

## TYPICAL APPLICATIONS

Two MC5442/7442 or MC9352/8352 decoders may be used to perform 4-line to 16-line decoding. Data inputs A, B, and C are paralleled to the two decoders, while input D is applied to one decoder and  $\bar{D}$  to the other. (See Figure 1.)

The excess 3 code is similar to the BCD code except that 3 is added to each digit before coding. This code has the advantage of being self-complementing. If all zeros in a BCD number are changed to ones and all ones are changed to zeros, the nine's complement of the decimal number is obtained. The ability to obtain the nine's complement can reduce the hardware necessary to perform subtraction. (See Figure 2.)

All Gray codes have one basic characteristic in common. As the code is advanced from any number to the next, only one bit of the code will change at a time. When a non-Gray code such as straight binary is advanced from 3 to 4 (0011 to 0100) three bits of the code must change. Since in many applications the voltages on the three lines do not change simultaneously, a number of false outputs may be generated which last for a short time. These false outputs are easily accepted by the high-speed devices now in use. In contrast, the excess 3 Gray code of the MC5444/7444 would change from 0101 to 0100 to advance from 3 to 4.

Analog measuring devices require a converter for information fed to a digital system. These converters usually use a Gray code output. Gray codes are also useful in sequential circuitry because of the change of only one bit at a time.

Figure 3 shows the MC5444/7444, MC9354/8354 used for decoding 3-line binary to octal. The input to A, B, and D is the binary code ABC. The C input of the device is used as a strobe. Octal data is taken from Outputs Q1 through Q8 when the strobe is taken to logic "1". Outputs Q0 and Q9 are not used.

FIGURE 1 — BINARY-TO-DECIMAL DECODING USING MC5442/7442, MC9352/8352

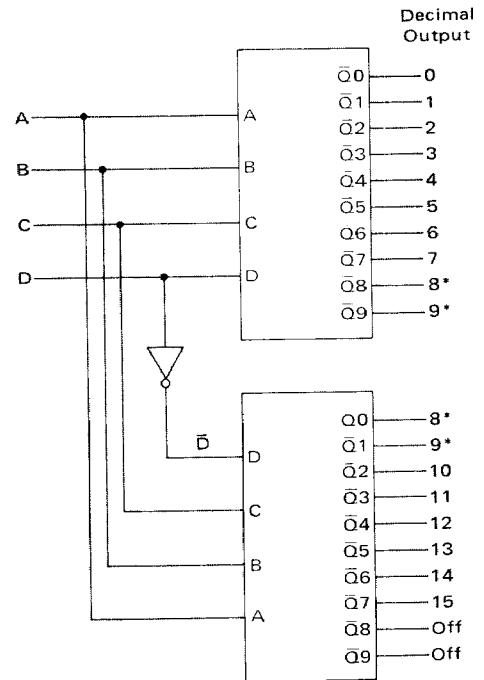

\*These decimal outputs are available from both decoders.

FIGURE 2 — 4-LINE EXCESS THREE CODE-TO-NINES COMPLEMENT DECIMAL DECODING USING MC5443/7443, MC9353/8353

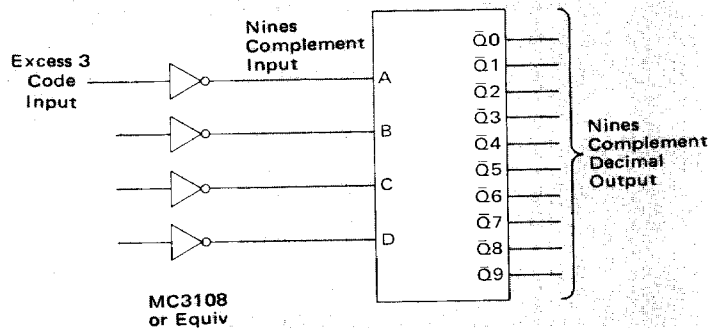
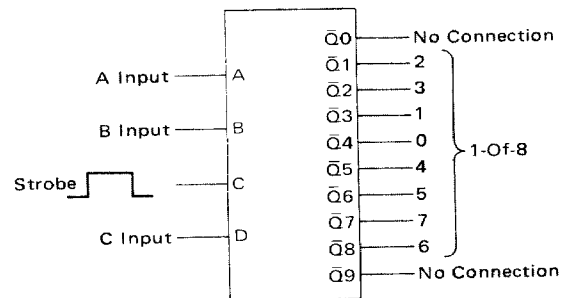

FIGURE 3 — 3-LINE BINARY-TO-OCTAL DECODING USING MC5444/7444, MC9354/8354



MC5443/MC7443, MC9353/MC8353

ELECTRICAL CHARACTERISTICS

Test procedures are shown for only one input and one output. Test other inputs and outputs in the same manner according to the truth table. Additionally, test all input-output combinations according to the truth table.

													TEST CURRENT/VOLTAGE VALUES (All Temperatures)											
													mA		Volts									
													I <sub>OL</sub>	I <sub>OH</sub>	V <sub>IL</sub>	V <sub>IH</sub>	V <sub>ILT</sub>	V <sub>IHT</sub>	BV <sub>in</sub>	V <sub>CC</sub>	V <sub>CCCL</sub>	V <sub>CCH</sub>	V <sub>IHX</sub>	
													16	-0.4	0.4	2.4	0.8	2.0	5.5	5.0	4.5	5.5	4.5	
													16	-0.4	0.4	2.4	0.8	2.0	5.5	5.0	4.75	5.25	4.5	
													TEST CURRENT/VOLTAGE APPLIED TO PINS LISTED BELOW:											
Characteristic	Symbol	Pin Under Test	MC5443, MC9353 Test Limits -55 to +125°C			MC7443/MC8353 Test Limits 0 to +75°C			I <sub>OL</sub>	I <sub>OH</sub>	V <sub>IL</sub>	V <sub>IH</sub>	V <sub>ILT</sub>	V <sub>IHT</sub>	BV <sub>in</sub>	V <sub>CC</sub>	V <sub>CCCL</sub>	V <sub>CCH</sub>	V <sub>IHX</sub>	Gnd				
<b>Input</b>																								
Forward Current	I <sub>IL</sub>	12		-1.6	mAdc		-1.6	mAdc			12							16		8				
Leakage Current	I <sub>IH</sub>	12		40	μAdc		40	μAdc			12							16		8				
Breakdown Current	I <sub>in</sub>	12		1.0	mAdc		1.0	mAdc						12				16		8				
<b>Output</b>																								
Output Voltage	V <sub>OL</sub>	1		0.4	Vdc		0.4	Vdc	1				12,13	14,15				16		8				
	V <sub>OH</sub>	1	2.4		Vdc	2.4		Vdc		1			14	12,13,15				16		8				
Short-Circuit Current	I <sub>OS1</sub>	1	-20	-55	mAdc	-18	-55	mAdc					12					12,13,15	16	1,8,14				
<b>Power Requirements (Total Device)</b>																								
Power Supply Drain	I <sub>CC</sub>	16		41	mAdc		56	mAdc										16		8,12,13,14,15				
<b>Switching Parameters*</b>									Pulse In	Pulse Out														
Two Logic Levels Turn-On Delay	t <sub>PHL2</sub>	15,2	10*	30*	ns	10*	30*	ns	15	2					16				13	8,12,14				
Turn-Off Delay	t <sub>PLH2</sub>	15,2	10*	25*	ns	10*	25*	ns	15	2					16				13	8,12,14				
Three Logic Levels Turn-On Delay	t <sub>PHL3</sub>	15,3		35*	ns		35*	ns	15	3					16				13	8,12,14				
Turn-Off Delay	t <sub>PLH3</sub>	15,3		35*	ns		35*	ns	15	3					16				13	8,12,14				

\*Tested only at 25°C.

†Only one output should be shorted at a time.

MC5444/MC7444, MC9354/MC8354

ELECTRICAL CHARACTERISTICS

Test procedures are shown for only one input and one output. Test other inputs and outputs in the same manner according to the truth table. Additionally, test all input-output combinations according to the truth table.

													TEST CURRENT/VOLTAGE VALUES (All Temperatures)											
													mA		Volts									
													I <sub>OL</sub>	I <sub>OH</sub>	V <sub>IL</sub>	V <sub>IH</sub>	V <sub>ILT</sub>	V <sub>IHT</sub>	BV <sub>in</sub>	V <sub>CC</sub>	V <sub>CCCL</sub>	V <sub>CCH</sub>	V <sub>IHX</sub>	
													16	-0.4	0.4	2.4	0.8	2.0	5.5	5.0	4.5	5.5	4.5	
													16	-0.4	0.4	2.4	0.8	2.0	5.5	5.0	4.75	5.25	4.5	
													TEST CURRENT/VOLTAGE APPLIED TO PINS LISTED BELOW:											
Characteristic	Symbol	Pin Under Test	MC5444/MC9354 Test Limits -55 to +125°C			MC7444/MC8354 Test Limits 0 to +75°C			I <sub>OL</sub>	I <sub>OH</sub>	V <sub>IL</sub>	V <sub>IH</sub>	V <sub>ILT</sub>	V <sub>IHT</sub>	BV <sub>in</sub>	V <sub>CC</sub>	V <sub>CCCL</sub>	V <sub>CCH</sub>	V <sub>IHX</sub>	Gnd				
<b>Input</b>																								
Forward Current	I <sub>IL</sub>	12		-1.6	mAdc		-1.6	mAdc			12							16		8				
Leakage Current	I <sub>IH</sub>	12		40	μAdc		40	μAdc			12							16		8				
Breakdown Current	I <sub>in</sub>	12		1.0	mAdc		1.0	mAdc						12				16		8				
<b>Output</b>																								
Output Voltage	V <sub>OL</sub>	1		0.4	Vdc		0.4	Vdc	1				12,13,15	14				16		8				
	V <sub>OH</sub>	1	2.4		Vdc	2.4		Vdc		1			12,13	14,15				16		8				
Short-Circuit Current	I <sub>OS1</sub>	1	-20	-55	mAdc	-18	-55	mAdc										14,15	16	1,8,12,13				
<b>Power Requirements (Total Device)</b>																								
Power Supply Drain	I <sub>CC</sub>	16		41	mAdc		56	mAdc										16		8,12,13,14,15				
<b>Switching Parameters*</b>									Pulse In	Pulse Out														
Two Logic Levels Turn-On Delay	t <sub>PHL2</sub>	15,2	10*	30*	ns	10*	30*	ns	13	1					16				14	8,12,15				
Turn-Off Delay	t <sub>PLH2</sub>	15,2	10*	25*	ns	10*	25*	ns	13	1					16				14	8,12,15				
Three Logic Levels Turn-On Delay	t <sub>PHL3</sub>	15,3		35*	ns		35*	ns	13	2					16				14	8,12,15				
Turn-Off Delay	t <sub>PLH3</sub>	15,3		35*	ns		35*	ns	13	2					16				14	8,12,15				

\*Tested only at 25°C.

†Only one output should be shorted at a time.