

REVISIONS					
REV	ECO	DESCRIPTION	DATE	BY	APPR
A1	-	RELEASE NEW DRAWING	12/JUL/22	LOUIE	TOMMY

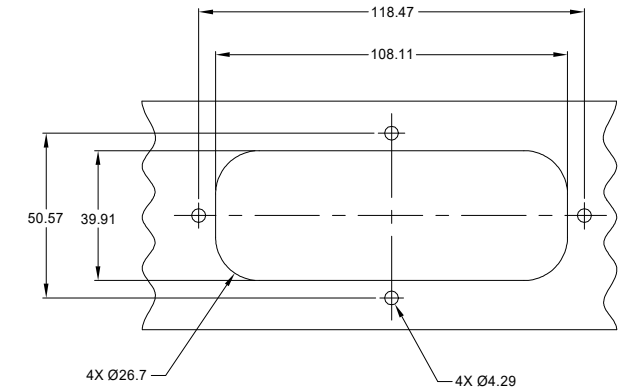
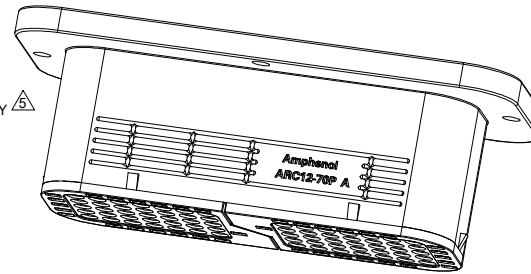
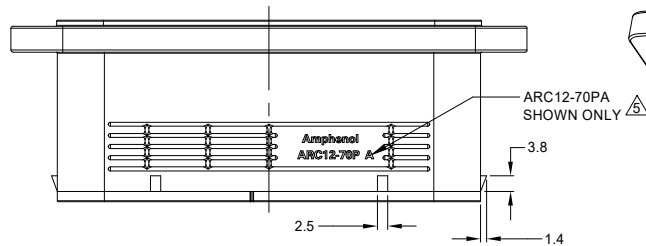
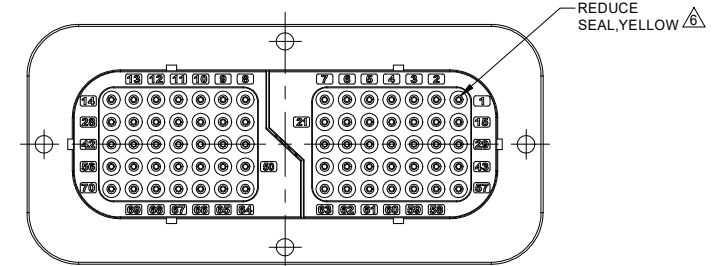
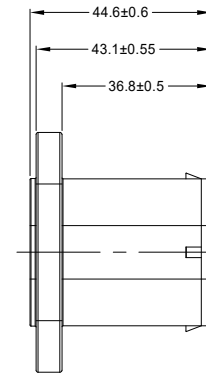
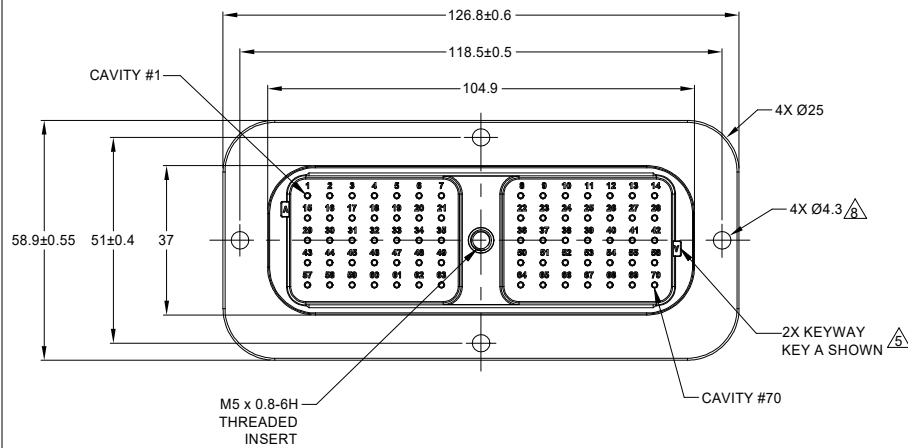

NOTES: UNLESS OTHERWISE SPECIFIED

- MATERIAL:
HOUSING: THERMOPLASTIC, BLACK
SEAL: SILICONE RUBBER
THREADED INSERT: STAINLESS STEEL
- MODIFICATIONS: FLANGE MOUNT;
REDUCE DIA. WIRE SEAL
- SPECIFICATIONS:
3.1 CURRENT RATING: 13 AMPS
3.2 OPERATING TEMPERATURE: -55°C TO +125°C
3.3 DIELECTRIC WITHSTANDING VOLTAGE: LESS THAN 2 MILLIAMPS CURRENT LEAKAGE @ 1500 VOLTS AC
3.4 INSULATION RESISTANCE: 1000 MEGOHMS MIN @ 25°C
3.5 MOISTURE RESISTANCE:
IP68 (1M OF WATER FOR A PERIOD OF 24 HOURS, MATED CONDITION);
IP69K(MATED CONDITION)
3.6 MATING CYCLE DURABILITY: 100 CYCLES
3.7 RoHS COMPLIANT
- MATING PART: ARC16-70SX* PLUG
(X = A,B,C,D KEYS ; * = ALL MODIFICATIONS)

SEE SHEET 2 FOR OTHER KEY ARRANGEMENTS

CONTACT SIZE AND REAR SEAL WIRE RANGE:

CONTACT SIZE	MIN. INSUL O.D.	MAX. INSUL O.D.	TYPICAL WIRE RANGE
16	1.35 mm (.053 in)	3.05 mm (.120 in)	14 - 20 AWG (2.0 - 0.5 mm ²)

RECEPTACLE IS SUPPLIED WITH DUST CAP

RECOMMENDED SCREW: 8-32 [M4]
TORQUE: 20 - 25 IN-LB [2.26 - 2.82 Nm]

ALL DIMENSIONS ARE FOR REFERENCE USE ONLY

SEE SHEET 2		DESCRIPTION		ITEM
QUANTITY	PART NUMBER	MATERIALS LIST		
UNLESS OTHERWISE SPECIFIED				
1) All dimensions are in metric(mm).				
2) Tolerances are as follows:				
1 PL DEC ±0.30 Fractions ±1/64				
2 PL DEC ±0.15 Angles ±1°				
3) Note reference =				
SIGNATURES		DATE		
DRAWN: LOUIE YIN		12/JUL/22		
CHECKED: ORION LIU		13/JUL/22		
ENGINEER:				
APPROVAL: TOMMY XIE		14/JUL/22		
CUSTOMER:				
MATERIAL SPECIFICATIONS:				
PROCESS SPECIFICATIONS:		THIS DRAWING IS SUPPLIED FOR INFORMATION ONLY. DESIGN FEATURES, SPECIFICATIONS AND PERFORMANCE DATA SHOWN HEREON ARE THE PROPERTY OF THE AMPHENOL CORPORATION. NO RIGHTS OF REPRODUCTION ARE IMPLIED. ALL DIMENSIONS ARE SUBJECT TO NORMAL MANUFACTURING VARIATIONS.		
NEXT ASSY:				
SIZE	TYPE	DWG NO:	REVISION	
B	C-	ARC12-70PXR	A1	
SCALE	NONE	SHEET 1 OF 2		

TITLE: 70 POS, RECEPTACLE, PIN,ARC SERIES,KEYED, REDUCE SEAL, BLACK
DWG NO.: ARC12-70PXR
REV: A1
SH: 1
OF: 2

REVISIONS					
REV	ECO	DESCRIPTION	DATE	BY	APPR
A1	-	RELEASE NEW DRAWING	12/JUL/22	LOUIE	TOMMY

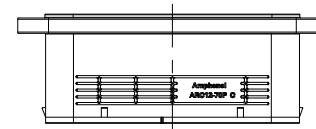
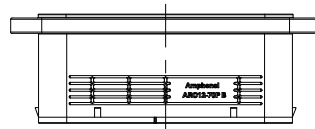
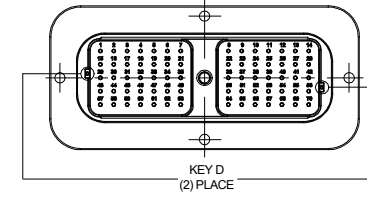
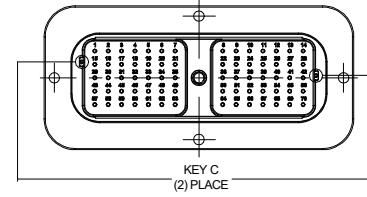
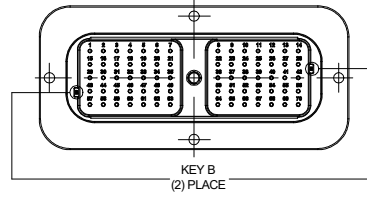
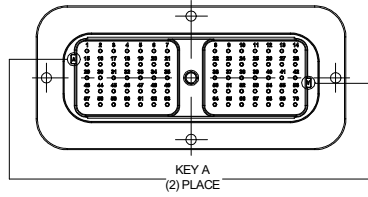

ARC12-70PX VARIANTS	
PART NUMBER	REF
ARC12-70PAR	DRC12-70PAE

ARC12-70PX VARIANTS	
PART NUMBER	REF
ARC12-70PBR	DRC12-70PBE

ARC12-70PX VARIANTS	
PART NUMBER	REF
ARC12-70PCR	DRC12-70PCE

ARC12-70PX VARIANTS	
PART NUMBER	REF
ARC12-70PDR	DRC12-70PDE

ARC12-70PXR		DESCRIPTION		ITEM
QUANTITY	PART NUMBER	MATERIALS LIST		
<p>UNLESS OTHERWISE SPECIFIED</p> <p>1) All dimensions are in metric (mm).</p> <p>2) Tolerances are as follows:</p> <p>1 PL DEC ±0.30 Fractions ±1/64</p> <p>2 PL DEC ±0.15 Angles ±1°</p> <p>3 PL DEC ±0.08</p> <p>3) Note reference = </p>				
<p>SIGNATURES</p> <p>DRAWN: LOUIE YIN 12/JUL/22</p> <p>CHECKED: ORION LI 13/JUL/22</p> <p>ENGINEER:</p> <p>APPROVAL: TOMMY XIE 14/JUL/22</p> <p>CUSTOMER:</p>		<p>DATE</p>		
<p>MATERIAL SPECIFICATIONS:</p> <p>PROCESS SPECIFICATIONS:</p> <p>NEXT ASSY:</p>		<p>THIS DRAWING IS SUPPLIED FOR INFORMATION ONLY. DESIGN FEATURES, SPECIFICATIONS AND PERFORMANCE DATA SHOWN HEREON ARE THE PROPERTY OF THE AMPHENOL CORPORATION. NO RIGHTS OF REPRODUCTION ARE IMPLIED. ALL DIMENSIONS ARE SUBJECT TO NORMAL MANUFACTURING VARIATIONS.</p>		
<p>Amphenol</p> <p>Sine Systems - www.amphenol-sine.com 44724 Morley Drive Clinton Township, MI 48036</p>		<p>70 POS, RECEPTACLE, PIN, ARC SERIES, KEYED, REDUCE SEAL, BLACK</p>		
<p>THIS DRAWING IS SUPPLIED FOR INFORMATION ONLY. DESIGN FEATURES, SPECIFICATIONS AND PERFORMANCE DATA SHOWN HEREON ARE THE PROPERTY OF THE AMPHENOL CORPORATION. NO RIGHTS OF REPRODUCTION ARE IMPLIED. ALL DIMENSIONS ARE SUBJECT TO NORMAL MANUFACTURING VARIATIONS.</p>		<p>SIZE</p> <p>B C-</p>	<p>TYPE</p> <p>ARC12-70PXR</p>	<p>DWG NO:</p> <p>A1</p>
<p>SCALE</p> <p>NONE</p>		<p>SHEET 2 OF 2</p>		

TITLE: 70 POS, RECEPTACLE, PIN, ARC SERIES, KEYED, REDUCE SEAL, BLACK
 DWG NO.: ARC12-70PXR
 REV: A1
 SH: 2
 OF: 2