

REVISIONS			
REV	DESCRIPTION, ECN, EAR NO.	DATE	APP'D
A	PROPOSAL	NOV 21/17	L.CHAN

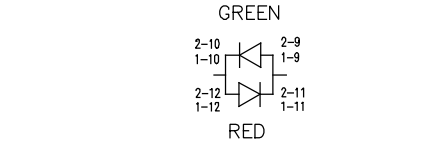

BI-COLOUR LED DETAIL
(GREEN/YELLOW, RED/YELLOW AND GREEN/ORANGE ARE ALSO AVAILABLE)

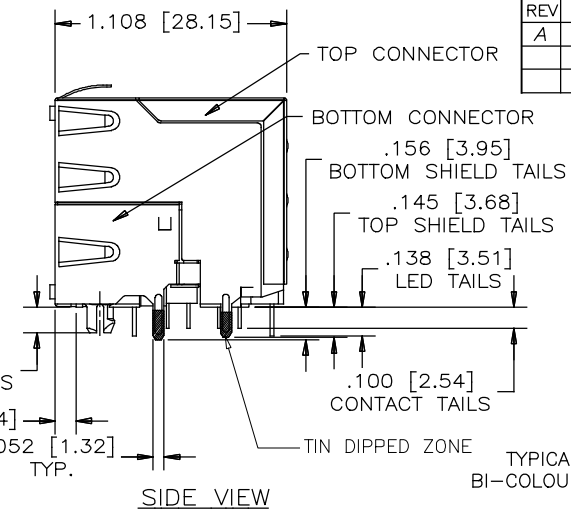
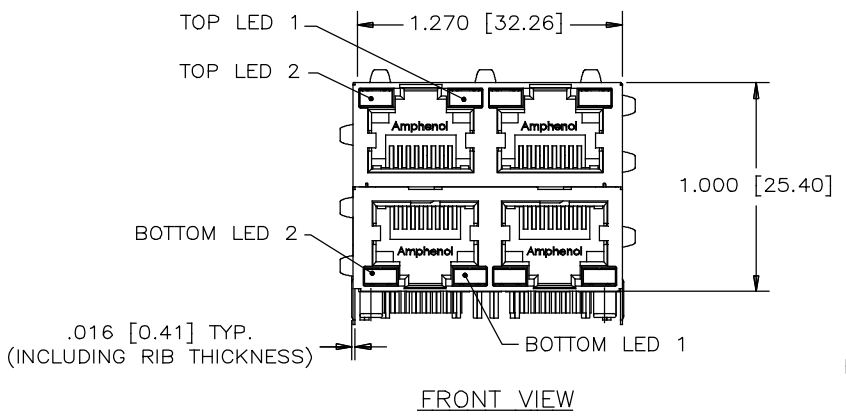
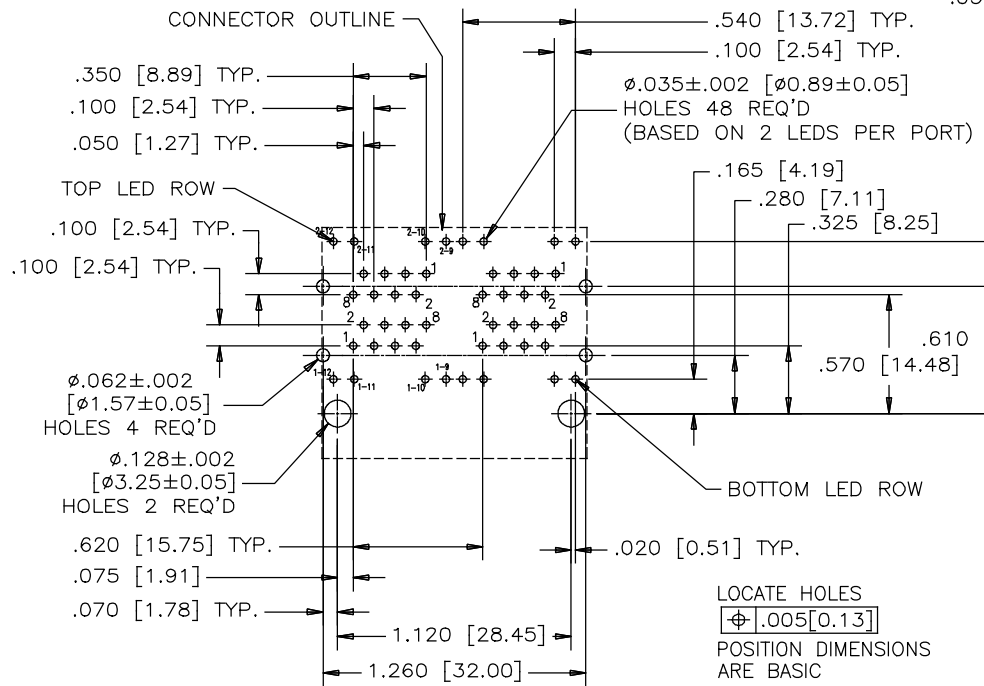
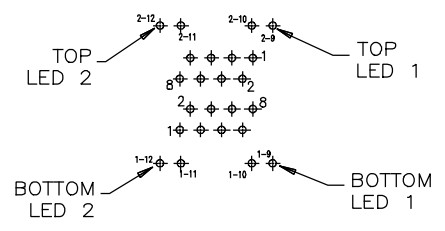
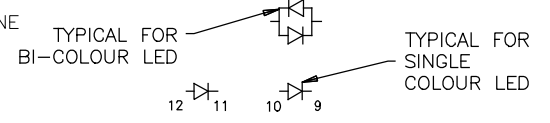

RECOMMENDED P.C.B. LAYOUT
(COMPONENT SIDE OF BOARD)
TOLERANCE: ±0.05 [0.02]

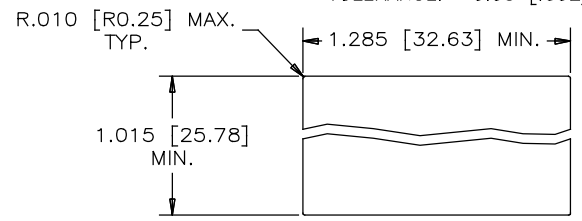

RECOMMENDED PANEL LAYOUT

MATERIALS:
HOUSING: HIGH TEMPERATURE THERMOPLASTIC. FLAMMABILITY RATING UL 94V-0, BLACK.
CONTACTS: PHOSPHOR BRONZE
PLATING: SELECTIVE GOLD PLATING ON MATING SURFACES SEE AMPHENOL PART NUMBER FOR DETAIL.
50µ" [1.27 MICRONS] MIN. NICKEL UNDERPLATE.
100µ" MIN. MATTE TIN OR GOLD FLASH ON CONTACT AILS.
SHIELD: COPPER ALLOY
PLATING: NICKEL WITH TIN DIPPED TAILS.
RECOMMENDED SOLDERING TEMPERATURE:
WAVE SOLDERING AT 260°C MAXIMUM FOR 5 SEC MAXIMUM.

AMPHENOL PART NUMBER: RJSAE-X38X-04X

GOLD PLATING OPTION:
D = 6 µ" GOLD PLATING
G = 15µ" GOLD PLATING
J = 30µ" GOLD PLATING
5 = 50µ" GOLD PLATING
REFER TO LED OPTIONS DRAWING FOR ORDERING CODES



UNLESS SPECIFIED OTHERWISE	DRAWN HANSON.C	DATE NOV 21/17	Amphenol Canada Corp. www.amphenolcanada.com
PRIMARY UNITS INCH	CHECKED AMY.Z	NOV 21/17	
SECONDARY MILLIMETER	M.E. APP'D		TITLE STACKABLE MULTI-PORT MODULAR JACK, SHIELDED, 4 PORTS, 2 PIECE CONSTRUCTION(8 POSITION, 8 CONTACTS, WITH LEDS) - RoHS COMPLIANT
REFERENCE IN PARENTHESES	Q.A. APP'D		
GENERAL TOLERANCES	DWG APPR.		DWG. NO.
1 DECIMAL PLACE ±0.025	ENG. REL. NO.		P-RJSAE-X38X-04X
2 DECIMAL PLACES ±0.020	REF. EAR#: RJ17222		
3 DECIMAL PLACES ±0.015	THIRD ANGLE PROJECTION		REV A
ANGULAR DEGREES ±1.0°	DO NOT SCALE DRAWING		CODE ID NO. 03554 DWG SIZE: C SCALE: N/A SHEET 1 OF 3

REVISIONS			
REV	DESCRIPTION, ECN, EAR NO.	DATE	APP'D
A	PROPOSAL	NOV 21/17	L.CHAN

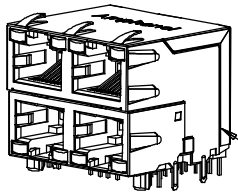

CONNECTOR

CONNECTOR PLACE INTO FOAM

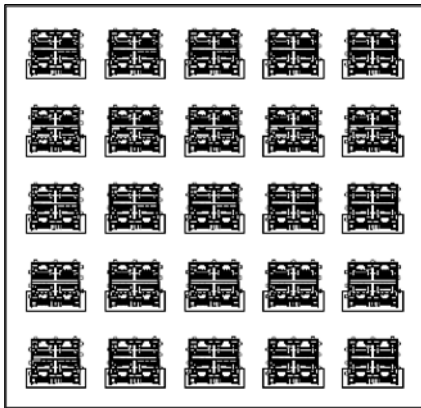

25PCS CONNECTOR PER FOAM



6 PIZZA BOX IN CARTON

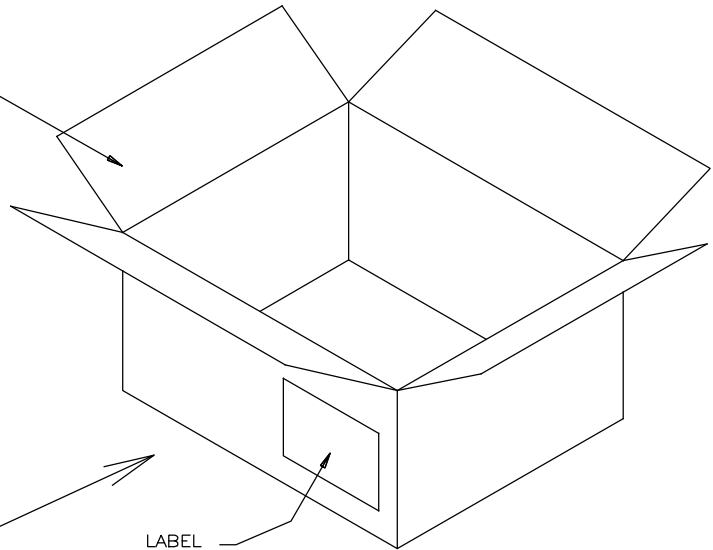

LABEL

SEAL THE CARTON

PLACE FOAM INSERT INTO PIZZA BOX

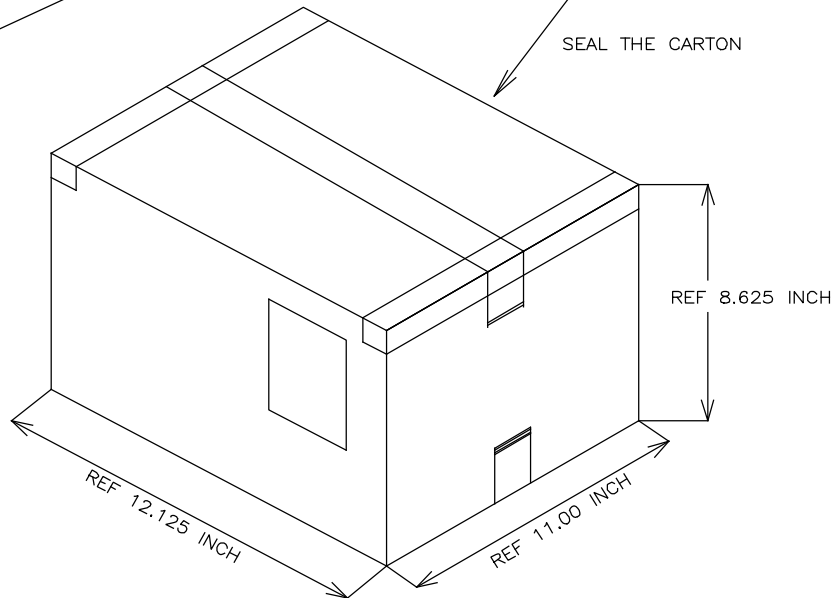
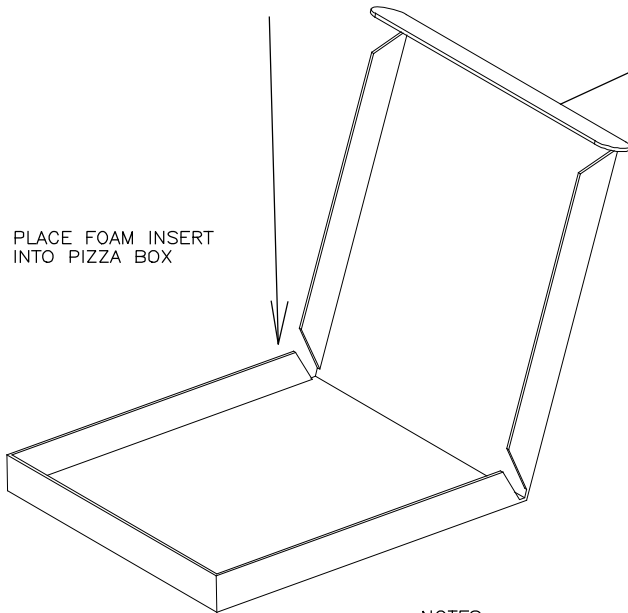

NOTES:

- PACAKING QUANTITY
 1. 25PCS PER FOAM
 2. 6 PCS PIZZA BOX PER CARTON
 150 PCS CONNECTORS PER CARTON

UNLESS SPECIFIED OTHERWISE	DRAWN	HANSON.C	DATE	NOV 21/17
PRIMARY UNITS	INCH	CHECKED	AMY.Z	NOV 21/17
SECONDARY	MILLIMETER	M.E. APP'D		
REFERENCE IN PARENTHESES		Q.A. APP'D		
GENERAL TOLERANCES		DWG APPR.		
1 DECIMAL PLACE	±0.025	ENG. REL. NO.		
2 DECIMAL PLACES	±0.020	REF.	EAR#: RJ17222	
3 DECIMAL PLACES	±0.015	THIRD ANGLE PROJECTION		
ANGULAR DEGREES	±1.0°	DO NOT SCALE DRAWING		

Amphenol Canada Corp.		www.amphenolcanada.com	
TITLE STACKABLE MULTI-PORT MODULAR JACK, SHIELDED, 4 PORTS, 2 PIECE CONSTRUCTION(8 POSITION, 8 CONTACTS, WITH LEDS) - RoHS COMPLIANT			
DWG. NO.		P-RJSAE-X38X-04X	
CODE ID NO. 03554		DWG SIZE: C SCALE: N/A SHEET 2 OF 3	

REVISIONS			
REV	DESCRIPTION, ECN, EAR NO.	DATE	APP'D
H	PROPOSAL	JUL 04/12	L.CHAN
J	PROPOSAL	MAR 03/14	L.CHAN
K	ADD NEW COLOR OPTION	FEB 09/17	L.CHAN

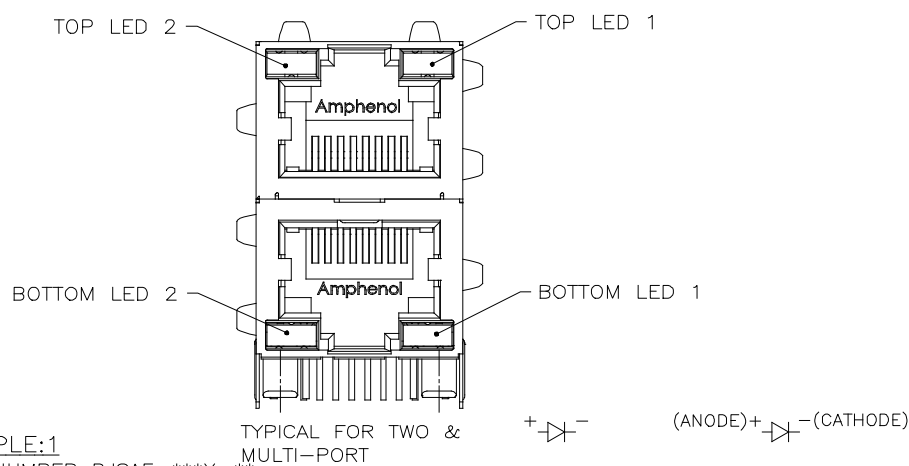

LED SPECIFICATIONS:
 FORWARD VOLTAGE: 2.1 VOLTS TYP.
 REVERSE VOLTAGE: 5.0 VOLTS MIN.
 LUMINOUS INTENSITY: 0.5 mCd MIN.
 (AT If=2mA)
 STORAGE TEMPERATURE: -20° TO 85° C
 PLATING ON TAILS: TIN OR TIN/COPPER ALLOY OVER SILVER

PRIMARY COLOR FOR BI-COLOR
 LEDS IN STANDARD ANODE/
 CATHODE CONFIGURATION IS:
 RED-GREEN= RED
 RED-YELLOW= RED
 GREEN-YELLOW= GREEN
 GREEN-ORANGE= GREEN



LEGEND
 BiC=BI-COLOR LED
 LOWC=LOW CURRENT LED
 YE=YELLOW
 GR=GREEN
 RD=RED
 OR=ORANGE

NOTES:
 1. THE TWO DIGITS PRECEDING THE ADDITIONAL LED CODE MUST BE USED IN THE PART NUMBER, WHEN ORDERING ANY OF THE ADDITIONAL LED OPTIONS.
 2. '*' REPRESENT DIFFERENT OPTION OF CONNECTOR, DETAIL OPTION PLEASE SEE RELEVANT CONNECTOR DRAWING.

EXAMPLE:1
 PART NUMBER RJS AE-***X-**



EXAMPLE:2
 PART NUMBER RJS AE-***U-**-XX



CODE	LED 2 (LEFT)	LED 1 (RIGHT)	CODE	LED 2 (LEFT)	LED 1 (RIGHT)	CODE	LED 2 (LEFT)	LED 1 (RIGHT)
0	BLOCKED	BLOCKED	9	GREEN	BLOCKED	J	BiC RD/GR	YELLOW
1	YELLOW	GREEN	A	BiC GR/YE	BiC GR/YE	K	YELLOW	BiC GR/OR
2	BLOCKED	GREEN	B	BiC RD/GR	BiC RD/GR	L	BiC GR/YE	RED
3	YELLOW	BLOCKED	C	BiC RD/GR	BiC GR/YE	M	RED	YELLOW
4	GREEN	YELLOW	D	GREEN	BiC GR/YE	N	BiC GR/RD	BiC GR/YE
5	GREEN	GREEN	E	YELLOW	BiC GR/YE	P	GREEN	BiC RD/GR
6	YELLOW	YELLOW	F	BiC GR/YE	YELLOW	R	BiC GR/OR	GREEN
7	RED	GREEN	G	BiC GR/OR	BiC GR/OR	T	RED	RED
8	GREEN	RED	H	BiC GR/YE	GREEN	V	BiC RD/GR	GREEN
						W	ADDITIONAL OPTIONS	
						U	SPECIAL CODE FOR TOP & BOTTOM LEDS CONFIGURATION	

EXAMPLE:3
 PART NUMBER RJS AE-***W-**X

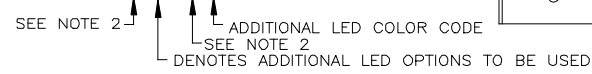

CODE	LED 2 (LEFT)	LED 1 (RIGHT)	CODE	LED 2 (LEFT)	LED 1 (RIGHT)	CODE	LED 2 (LEFT)	LED 1 (RIGHT)
0	DO NOT USE		5	BLOCKED	YELLOW	A	LOWC YE	LOWC YE
1	RED	BLOCKED	6	RED	BiC RD/GR	B	LOWC YE	LOWC GR
2	BiC GR/OR	YELLOW	7			C	LOWC GR	LOWC YE
3	YELLOW	RED	8	BiC RD/GR	BLOCKED	D	LOWC GR	LOWC GR
4	BLOCKED	RED	9	BiC GR/YE	BLOCKED	M	LOWC RD	LOWC YE
						N	GREEN	BiC GR/OR
						E	GREEN	ORANGE
						F	ORANGE	GREEN
						G	BiC YE/GR	BiC YE/GR
						P	BiC RD/YE	GREEN
						R	BiC RD/YE	BiC RD/YE
						T	BiC GR/YE	BiC RD/GR
						H	BLUE	RED

EXAMPLE:4
 PART NUMBER RJS AE-***X-**XX*

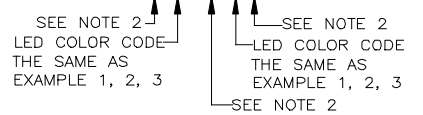

UNLESS SPECIFIED OTHERWISE	DRAWN	PAUL WANG	DATE	JUL 22/05	Amphenol Canada Corp. www.amphenolcanada.com
	PRIMARY UNITS	CHECKED	LAWRENCE C.	JUL 22/05	
SECONDARY	M.E. APP'D				TITLE
REFERENCE IN PARENTHESES	Q.A. APP'D				LED OPTIONS FOR RJS AE, MULTI-PORT CONNECTORS - RoHS COMPLIANT
GENERAL TOLERANCES	DWG APPR.				DWG. NO.
1 DECIMAL PLACE	ENG. REL. NO.				P-RJS AE-LEDS
2 DECIMAL PLACES	REF.				REV
3 DECIMAL PLACES	THIRD ANGLE PROJECTION				K
ANGULAR DEGREES	DO NOT SCALE DRAWING				CODE ID NO. 03554 DWG SIZE: C SCALE: N/A SHEET 1 OF 1