



( -.&(/ .-. 0 (/ -

1 2&



! " ! " # \$ %& \$\$ ' ( % ) \* ' ) +

*SPECIFICATIONS SUBJECT TO CHANGE WITHOUT NOTICE*

**Notice**

While reasonable efforts have been made to assure the accuracy of this document, Telit assumes no liability resulting from any inaccuracies or omissions in this document, or from use of the information obtained herein. The information in this document has been carefully checked and is believed to be entirely reliable. However, no responsibility is assumed for inaccuracies or omissions. Telit reserves the right to make changes to any products described herein and reserves the right to revise this document and to make changes from time to time in content hereof with no obligation to notify any person of revisions or changes. Telit does not assume any liability arising out of the application or use of any product, software, or circuit described herein; neither does it convey license under its patent rights or the rights of others.

It is possible that this publication may contain references to, or information about Telit products (machines and programs), programming, or services that are not announced in your country. Such references or information must not be construed to mean that Telit intends to announce such Telit products, programming, or services in your country.

**Copyrights**

This instruction manual and the Telit products described in this instruction manual may be, include or describe copyrighted Telit material, such as computer programs stored in semiconductor memories or other media. Laws in the Italy and other countries preserve for Telit and its licensors certain exclusive rights for copyrighted material, including the exclusive right to copy, reproduce in any form, distribute and make derivative works of the copyrighted material. Accordingly, any copyrighted material of Telit and its licensors contained herein or in the Telit products described in this instruction manual may not be copied, reproduced, distributed, merged or modified in any manner without the express written permission of Telit. Furthermore, the purchase of Telit products shall not be deemed to grant either directly or by implication, estoppel, or otherwise, any license under the copyrights, patents or patent applications of Telit, as arises by operation of law in the sale of a product.

**Computer Software Copyrights**

The Telit and 3rd Party supplied Software (SW) products described in this instruction manual may include copyrighted Telit and other 3rd Party supplied computer programs stored in semiconductor memories or other media. Laws in the Italy and other countries preserve for Telit and other 3rd Party supplied SW certain exclusive rights for copyrighted computer programs, including the exclusive right to copy or reproduce in any form the copyrighted computer program. Accordingly, any copyrighted Telit or other 3rd Party supplied SW computer programs contained in the Telit products described in this instruction manual may not be copied (reverse engineered) or reproduced in any manner without the express written permission of Telit or the 3rd Party SW supplier. Furthermore, the purchase of Telit products shall not be deemed to grant either directly or by implication, estoppel, or otherwise, any license under the copyrights, patents or patent applications of Telit or other 3rd Party supplied SW, except for the normal non-exclusive, royalty free license to use that arises by operation of law in the sale of a product.







3' '3' " : 5, = : > .....  
 3'+ ' % ) .....  
 3'+ ' % / ( )\$ 7 \$ = / ( > .....  
 3' ' \$ , 6 % = > .....  
 3'3' . .....  
 3'3' ' , % ) .....  
 3'3' ' ? , ( 1 , ) ..... +  
 3'3'+ ' : 1 1 , ) ..... +  
 3'3' ' ( 5% 7 % .....  
 3'3'3' 5 % & .....  
 3' ' : & % .....  
 3' ' .....  
 3' ' ' .....  
 ' , ) 7 .....  
 ' ' 9 % .....  
 ' ' 6 ) 7 \$ .....  
 ' & \$ 7( \$ ..... +  
 ' ' & % & \$ 7 ..... +  
 ' @AB \* % A ..... +  
 ' AB ) A ..... +  
 ' 7 \$\$ ..... ++  
 ' \$ < 7 ..... +



! " ! " # \$ % & \$\$ ' ( % ) \* ' ) +



’ .

’ ’

This document describes the main functionality of the Jupiter SE880 GPS Receiver.

The information in this document is subject to change without notice and describes only generally the product defined in the introduction of this documentation.

’ ’

(

This document is intended for customers and developer who are about to develop an application based on Jupiter SE880.

’+’

& . \$ 4

For general contact, technical support, to report documentation errors and to order manuals, contact Telit Technical Support Center (TTSC) at:

- [TS-EMEA@telit.com](mailto:TS-EMEA@telit.com)
- [TS-NORTHAMERICA@telit.com](mailto:TS-NORTHAMERICA@telit.com)
- [TS-LATINAMERICA@telit.com](mailto:TS-LATINAMERICA@telit.com)
- [TS-APAC@telit.com](mailto:TS-APAC@telit.com)

Alternatively, use:

<http://www.telit.com/en/products/technical-support-center/contact.php>

For detailed information about where you can buy the Telit modules or for recommendations on accessories and components visit:

<http://www.telit.com>

To register for product news and announcements or for product questions contact Telit Technical Support Center (TTSC).

Our aim is to make this guide as helpful as possible. Keep us informed of your comments and suggestions for improvements.

Telit appreciates feedback from the users of our information.



' , \$ 1 ) #

This document contains the following chapters :

[Chapter 1: “Introduction”](#) provides a scope for this document, target audience, contact and support information, and text conventions.

[Chapter 2: “Overview”](#) gives an overview of the features of the product.

[Chapter 3: “General Product description”](#) describes in details the characteristics of the product.

[Chapter 4: “Environmental requirements”](#) deals about environmental spec.

[Chapter 5: “SE880 Characteristics”](#) gives an overview of the product’s characteristics including power supply, communication ports and pinout.

[Chapter 6: “Mounting on your board”](#) describes how to handle the device and its packaging system.

[Chapter 7: “Conformity Assessment”](#) provides overview about product assessments.

[Chapter 8: “Evaluation Kit”](#) provides a scope an overview about the SE880 Evaluation kit.

[Chapter 9: “Reference Design Kit”](#) provides a scope an overview about the SE880 Reference kit

[Chapter 10: “Conformity Assessment Issues”](#) provides some fundamental hints about the conformity assessment that the final application might need.

[Chapter 11: “Safety Recommendation”](#) provides some safety recommendations that must be followed by the customer in the design of the application that makes use of the AA99-XXX.

'3' 5 & \*



***Danger – This information MUST be followed or catastrophic equipment failure or bodily injury may occur.***



***Caution or Warning – Alerts the user to important points about integrating the module, if these points are not followed, the module and end user equipment may fail or malfunction.***



**Tip or Information – Provides advice and suggestions that may be useful when integrating the module.**

All dates are in ISO 8601 format, i.e. YYYY-MM-DD.

' , % \$

- Jupiter SE880 Hardware User Guide
- Jupiter SE880 EVK User Guide



! " ! " # \$ % & \$\$ ' ( % ) \* ' ) +



- Jupiter SE880 Ref Design User Guide



! " # \$ % & ' ( ) +

' 1 \* \* !

The Telit's Jupiter SE880 is the world smallest, turnkey GPS SiP navigation solution in a 4.7 x 4.7 x 1.4 mm package, incorporating significant feature additions to and performance improvements on predecessor SiRFstarIV receiver functionality.

The miniature 4.7x4.7mm LGA (Land Grid Array), SiRFstarIV™-based receiver module employs leading 3-D component embedding technology to achieve best-in-class performance in all dimensions critical for regular or size-constrained GPS applications. The receiver module was conceived to shorten Time-to-Market and to make the chipset-versus-module decision an easy one to make for device integrators. Integrators can attain a working -based design in as little as a week versus several months when starting from a chipset reference design.

Telit's Jupiter includes all components necessary for a fully functioning receiver design requiring only a 32 KHz external crystal for its time-base and TCXO to complete the design, along with antenna, power and data connections adequate to the integrator's needs. For advanced designs incorporating the supported Satellite Based Augmentation System (SBAS), ephemeris data collected from the satellites can be stored to SPI Flash memory instead of the more common and expensive alternative of the EEPROM - again reducing costs and improving the business case for the end-device.

Responsible for delivering the device's best-in-class sensitivity, the Jupiter's RF front-end is truly state of the art employing spatially calibrated waveguide-quality radio paths inside the three-dimensional space of its architecture drastically reducing parasitic impedances characteristic of traditional 2-D RF designs. Inside, a multi-filter system includes not only the traditional SAW filters typical in GPS receiver designs but also a 2.4 GHz notch-filter capable of nullifying the jamming effects of high-energy radio devices such as Wi-Fi hot-spots, Bluetooth systems, cordless phones, and others, which greatly affect a GPS receiver's ability to resolve timid satellite signals in the hostile radio environment where they need to operate.

Jupiter SE880 is a single-constellation GPS product enhanced for maximum sensitivity which makes it capable of class-unique achievements such as a one-satellite acquisition of UTC (typically 4 are required); fix acquisition with minimal sky-visibility – indoors, garages, urban canyons, etc.; and much lower. In its micro-power stand-by mode, the draws a low 50 to 500 µAmps making it extremely battery-power friendly.

SE880 lowers system costs and risk, while delivering state of the art GPS performance with as few as five external components (TCXO, RTC and three cap) with space requirement as little as 38 mm<sup>2</sup>. SE880 is carefully designed on all I/O assignment to simplify PCB layout and noise suppression on a 2-layers PCB integration capability for further cost saving.



! " ! " # \$ % & \$\$ ' ( % ) \* ' ) +

, ,

## 6 7 8

The SE880 provide customers the following benefits:

- The solution cost and footprint are significantly reduced (less than 40mm<sup>2</sup>) compared to chipset implementation and conventional module technology.
- The SE880's advanced 3D SiP technology allows best-in-class TTFF and in-door sensitivity.
- The deeply integrated SAW filter and 2.4GHz notch filter greatly enhanced location accuracy by removing unwanted noise power in the most crowded frequency spectrums.
- The SE880 supports assisted ephemeris file injection (A-GPS) as well as Satellite Based Augmentation System (SBAS).
- "1 SV Fast Time Setting" for watch and clock applications.
- Provides internal data logging feature with SPI Flash memory.
- Enables ultra compact and effective antenna integration (passive patch, chip, printed or conformal antenna) in a very small space with a 2-layers PCB.
- Very quick turn-around time with minimal BOM of TCXO, 32kHz crystal, and a few passive.
- Telit SE880 bundled with a Telit cellular module represents the ideal Wireless+GPS solution in terms of total cost effectiveness, footprint solution, integration and time-to-market readiness.



! " ! " # \$ % & \$ \$ ' ( % ) \* ' ) +

' , + " %) 7

The Jupiter SE880 is a 3D SiP (System in Package) device. the 3D technology allows to embed active and passive components into the PCB.

SiP means the integration of several integrated circuits and components of various technologies in a single package, resulting in one or several electronic systems.

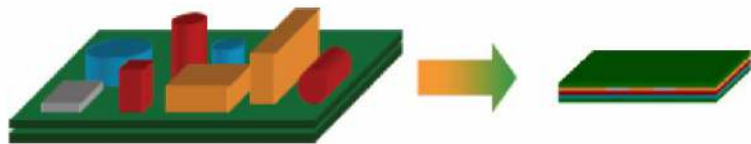

SiP Concept

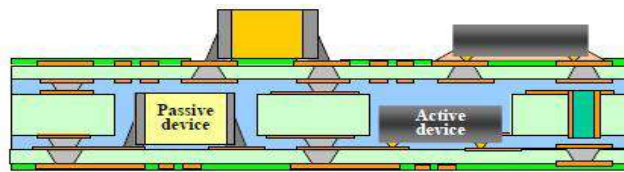

3D PCB package

3D SiP key benefits are :

- Miniaturization
- Functional performance improvement
- Combination of several functions
- Excellent electrical by low inductances
- Excellent thermal performance (top and back side heat transfer)
- Embedded EMI shield
- Cost reduction
- Speed-to-market due to the reuse of existing ICs
- Complete system integration



'+' . % % 6 ) \$

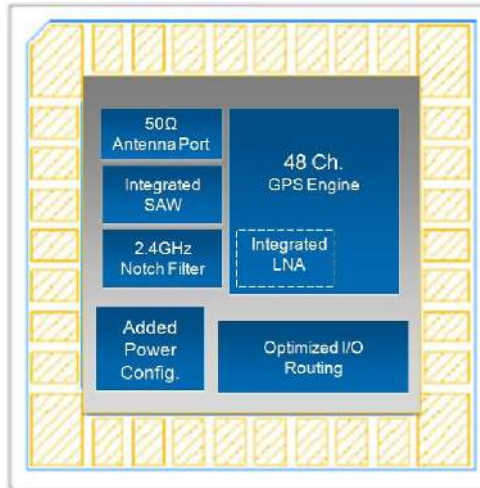

' , \$

The Telit Jupiter module overall dimensions are:

- Length: 4.7mm
- Width: 4.7 mm
- Thickness: 1.4 mm
- Weight 0.04 g

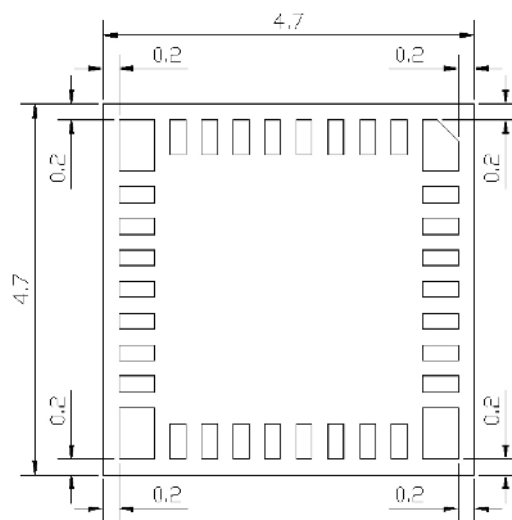

Note: Bottom view in mm





'3'

\$ \$ % 5 % 1,

The Jupiter SE880 requires two external reference clocks:

- 16.369MHz TCXO
- 32.768kHz (XTal)

antenna and a 1.8V always ON supply.

Supply can be a 1.8V supply that is backed up by a very low current 1.8V LDO that will supply the 20uA typical when the GPS has been shut down into Hibernate mode.

An EEPROM / SPI Flash memory can be added in order to store CGEE and/or SW patches.

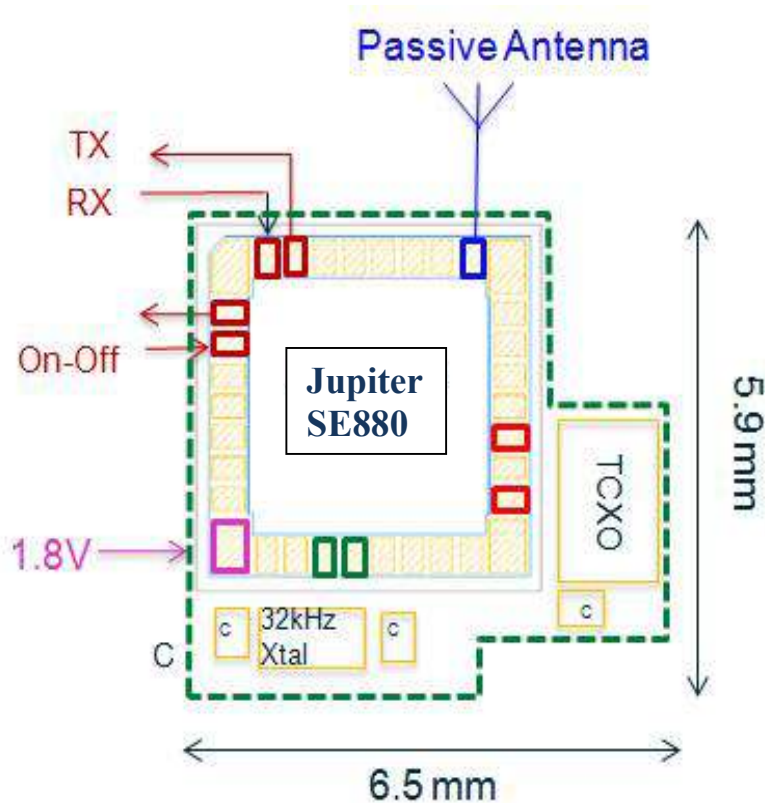

! " ! " # \$ % & \$ \$ ' ( ' ( % ) " \* ' ) +



+ ' 9 %

+ ' ' , :

Jupiter includes a high performing SiRF Star IV GPS chipset (ROM) in a 3D PCB technology ensuring top-level performances at the lower integration cost. Min features are:

- Ultra high sensitivity frontend without the need of active antenna
- High-sensitivity navigation engine (PVT) tracks as low as -165dBm
- 48 track verification channels
- SBAS (WAAS, EGNOS, QZSS and others)
- Adaptive Micropower Controller:
  - Only 50 to 500µA maintains hot start capability
  - <10mW required for TricklePower mode
- Three Stages Passive and Active Jammer Remover:
  - Integrated pre-selection SAW filter at antenna port
  - Integrated notch filter attenuates unwanted energy at 2.4GHz up to 50dB
  - In-band jammers removal up to 80dB-Hz
  - Tracks up to 8 CW jammers
- Advanced Navigation Features:
  - Smart sensor I<sup>2</sup>C interface
  - Embedded Data logger
  - 1-SV fast time sync for rapid UTC update
  - Measurement smoothing for pedestrians mode
  - A-GPS (free 3-days CGEE and 14days SGEE; expandable to 31 days SGEE)

Easy integration and use:

- minimal external BOM of 5 to 6 components
- Typical solution footprint on 2-layer PCB: 38mm<sup>2</sup>
- Optional external memory (EEPROM or Flash)
- Single 1.8V supply with integrated LDO and switcher mode
- GPIO Baud Rate and Protocol Detection
- Fail safe I/O, including RTC and TCXO inputs
- Host I<sup>2</sup>C, SPI and UART supported



+ ' '

+ ' ' ' 9 %

<b>Supported GNSS and Freq</b>	GPS L1 C/A-code
<b>Chipset</b>	SiRFStar IV, GSD4e ROM
<b>Channels</b>	48
<b>Tracking sensitivity</b>	-165 dBm
<b>Navigation sensitivity</b>	-163 dBm
<b>Acquisition sensitivity</b>	-148 dBm
<b>Update rate</b>	1 Hz (Default), 5Hz
<b>Time to First Fix, Hot Start</b>	<1 s typ. (note 1)
<b>Time to First Fix, Warm Start</b>	<33 s typ. Or 10 s typ. with CGEE self-assistance (note1)
<b>Time to First Fix, Cold Start</b>	<33 s typ. (note 1) or 20 s typ. with CGEE self-assistance
<b>Current consumption</b>	<ul style="list-style-type: none"> <li>• Hibernate Mode current: 14 uA</li> <li>• Low power mode (Tracking 1 Hz): 10 mA</li> <li>• Average full power tracking in LDO mode : 35 mA</li> <li>• Average full power tracking in switcher mode: 28 mA</li> </ul>
<b>Operating temperature</b>	-40°C ~ +85°C
<b>Storage temperature</b>	-40°C ~ +85°C
<b>Host port configuration</b>	UART, SPI or I2C configurable
<b>Serial port protocol</b>	NMEA-0183 rev. 3.0 (configurable to SiRF binary OSP)
<b>Serial data format (UART)</b>	8 bits, no parity, 1 stop bit
<b>Baud Rate Detection</b>	4800/9600 baud configurable depending upon pull high or pull low with GPIO0 and GPIO1
<b>Dimensions</b>	4.7 x 4.7 x 1.4 mm typ.
<b>Package</b>	34 pins LGA 0.4mm pitch

Note 1: with nominal GPS signal levels -130dBm



! " ! " # \$ % & \$\$ ' ( ' ( % ) " \* ' ) +

+ ' ' ' & % %&"

Symbol	Parameter	Min	Typ	Max	Unit
VDD	Supply voltage input		1.8		V
IDD (peak)	Supply current, peak acq.		47	90	mA
IDD (ave)	Supply current average, tracking, LDO mode		37		mA
IDD (ave)	Supply current average, tracking, Switcher mode		30		mA
IDD (Hib)	Supply current, hibernate state		20		μA
VOL	Low level output voltage, IOL 2mA			0.4	V
VOH	High level output voltage, IOH 2mA	$0.75 \cdot V_{DD}$			V
VIL	Low level input voltage	-0.3		0.45	V
VIH	High level input voltage, IOH 2mA	$0.7 \cdot V_{DD}$		3.6	V
RPU	Internal pull-up resistor equivalent	50	86	157	kΩ
RPD	Internal pull-down resistor equivalent	51	91	180	kΩ
LI	Input leakage at VI=1.8V or 0V	-10		10	μA
LO	Tristate output leakage at VO=1.8V or 0V	-10		10	μA
CI	Input capacitance, digital output		8		pF



! " ! " # \$ %& \$\$ '( (% ) \* ' +

' \* \$ % ; \$  
' ' \$ )

	SE880	Notes
Operating Temperature Range	-40°C ÷ +85°C	
Storage Temperature Range	-40°C ÷ +85°C	

' ' < \$ %

Telit Jupiter SE880 module is fully compliant to EU RoHS Directives.



3' &"

3' ' ! %

The SE880 requires only one VDD supply voltage of 1.8 volts. Rather than having a “split” power supply design of main and backup, the SE880 manages all of its power modes internally and VDD supply intended to be kept alive all the time.

First power up may take 300ms (typical) due to internal RTC startup time after which the SE880 will enter into the lowest power “hibernate” state.

Upon pulsing the ON\_OFF signal, the SE880 will transition to the “operate” state.

Pulsing the ON-OFF signal a second time will transition the Se880 back into the “hibernate” state.



---

Power supply voltage, noise and ripple must be between 1.75V and 1.85V for all frequencies up to 3MHz. Above 3MHz, the noise and ripple component must not exceed  $\pm 15\text{mV}$ . To help meet these requirements, a separate LDO for the Se880 is suggested.

---

See HW User Guide for details.

3' ' ' / 7/ 6

In SE880, removal of the 1.8 volt supply results in losing RTC time and SRAM data. The main supply voltage can be switched to a backup supply external to the SE880 provided the receiver is allowed time to enter the hibernate state.

See HW User Guide for details.

3' ' ! , ) \$

After power up the SE880 boots from the internal ROM to Hibernate state. The operation of requires ON\_OFF interrupt to wake up for Normal (Navigation, Full on) mode.

Modes of operation:

- Full on (Navigation, Full Power)
- Power management system modes
- Hibernate state

Full on mode.

SE880 boots for internal 1.2V LDO regulator mode. Internal Switcher mode regulator reduces power consumption and requires a binary command from host to enable Switcher mode.



! " ! " # \$ % & \$ \$ ' ( % ) \* ' ) +

SE880 will enter Hibernate state after first power up with factory configuration settings. The Navigation mode will start after waking up from Hibernate state in cold start mode by sending ON\_OFF signal interrupt pulse from host. This mode is also referenced as Full on, Full Power or Navigation mode.

Navigation is available and any configuration settings are valid as long as the VDD power supply is active. When the VDD is powered off, settings are reset to factory configuration and receiver performs a cold start on next power up.

VDD supply is intended to be kept active all the time and navigation activity is suggested to be controlled.

3' ' ' <

This is the lowest power consumption state (20uA typical) and allows a Hot Start within 2-4 hours of last shut down. The GPS receiver must have had a valid fix with sufficient visible satellites before having been shut down via the ON-OFF line or serial command.



? Bf AGPS is used there will be no time limit as long as the AGPS data is still valid.

3' ' ' , ! ,

Micro Power mode is a very low power maintenance mode implementing SiRFaware™ technology. In this mode the SE880 remains predominantly in the Hibernate state, but exits this state only as needed to maintain location awareness and valid ephemeris data. Thus high sensitivity hot start conditions are always present when the ON-OFF signal is used to wake up the SE880 and obtain a navigation update.

3' '+ ( \* 6% ! ≠ >

Trickle Power mode is a duty-cycled power management mode that reduces average current consumption by the SE880 while retaining a high quality of GPS accuracy and dynamic motion response. The duty cycle and navigation update rate are specified by the user to best fit in the operating environment. This mode adapts to weak or blocked satellite signals by transitioning the SE880 in and out of full power mode as needed in order to maintain GPS performance.

3' ' ' ( \* ! , ) \$ ≠ , >

APM is designed for use in A-GPS wireless applications. This is a sophisticated power management scheme that this mode does not engage until all necessary information is received. Host can configure user-specified criteria such as number of APM cycles, time between fixes, power duty cycle, QoS and navigation solution accuracy.

3' '3' " : 5, = :>

Push to Fix mode is designed for applications that do not require frequent navigation updates. In this mode the SE880 remains in the hibernate state most of the time, but wakes up periodically to perform a hot start acquisition (up to once every two hours) and provide a





quality navigation solution. The also wakes up when requested by a signal on the ON-OFF line.

3'+' % )

3'+' ' % / ( )\$ 7 \$ = / ( >

The SE880 is capable of receiving WAAS and EGNOS, MSAS, GAGAN differential corrections which are regional implementations of SBAS. SBAS improves horizontal position accuracy by correcting GPS signal errors caused by ionospheric disturbances, timing and satellite orbit errors.

3' ' \$ , 6 % = >

A 1PPS time mark pulse is provided as an output with a width of 200ms. This signal has not been verified or characterized for all operational conditions.



3'3'

3'3' '

User can select the serial interface (host port) between UART, SPI (slave) or I<sup>2</sup>C (master/slave) during power up boot depending upon how the CTS\_SPI and RTS\_SPI pins are strapped at power up. Either leave the pin floating, apply a 10K resistor to +1.8V (PU) or apply a 100K resistor to GND (PD).

Mode	CTS_SPI (internal pull-down)	RTS_SPI (internal pull-up)
UART	PU	Leave floating
I2C	Leave floating	PD
SPI	Leave floating	Leave floating

GPI00 and GPI01 can be used to configure the serial interface to output NMEA at standard baud rates. If is not using I<sup>2</sup>C or SPI flash devices on GPI00 and GPI01. Table 4 lists the settings for GPI00 and GPI01 to configure the baud rate at start-up.

Table 5 GPIO Pull Directions for Configuring NMEA Output Rates at Start-up

GPI00	GPI01	Protocol	Baud Rate
Pull high	Pull high	NMEA	4800
Pull high	Pull low	NMEA	9600
Pull low	Pull high	NMEA	38400
Pull low	Pull low	OSP	115200



Note: The default data format for UART: 8 data bits, no parity, 1 stop bit

After start-up, the GPIOs can be released for other purposes.



! " ! " # \$ % & \$ \$ ' ( ' ( % ) " \* ' ) +

**Note:**



This flexibility is not available if any MEMS or non-volatile memory devices are attached to the auxiliary serial bus. The internal software default baud rate is NMEA 4800 when an EEPROM or SPI flash device is attached, but can be changed via a CCK patch or an OSP message.

Failure to tie GPIO0 and GPIO1 high or low in the absence of both SPI flash and EEPROM causes an increase in standby and hibernate current and also causes the start-up configuration of the UART to be indeterminate.

**3'3' ' ? , ( 1 , )**

NMEA v3.0 is the default protocol. The following messages are output by default:

- RMC = 1 second update
- GGA = 1 second update
- GSA = 1 second update
- GSV = 5 second update

Reference the NMEA protocol manual for additional message details.

**3'3'+ ' : 1 1 , )**

SiRF One Socket Protocol (OSP) is supported. This is an extension of the existing SiRF Binary protocol.

The following messages are output once per second:

- MID2
- MID4
- MID9
- MID41
- MID56, 5
- MID56, 35

Reference the SiRF One Socket Protocol manual for additional message details.



### 3'3' ( 5% 7 %

The provides an auxiliary serial interface that can be configured as either a master I<sup>2</sup>C interface or a master SPI bus. Only one of these buses may be implemented on a receiver.

At start-up, the receiver automatically detects either an I<sup>2</sup>C EEPROM or a SPI serial flash memory and sets itself appropriately. If does not detect memory of either type, the system is configured for an I<sup>2</sup>C bus for sensor interface.

### 3'3'3' 5 % &

The RF connection for the external antenna has a characteristic impedance of 50 ohms.

SE880 with its ultra sensitive RF frontend allows direct connection with passive antennas.

Jupiter SE880 has internal double stage LNA. LNA setting msut be done accordingly with the connected antenna and depending on the antenna gain in active antenna is used.

See SE880 HW User Guide for details.

### 3' ' : & %

Feature	Description	Availability
<b>SBAS (WAAS, EGNOS, QZSS)</b>	Improve position accuracy by using freely available satellite based correction services called SBAS (Satellite Based Augmentation System).	Yes
<b>Low Signal Acquisition</b>	Acquires satellites and continues tracking in extremely low signal environments.	Yes
<b>Low Signal Navigation</b>	Continues navigating in extremely low signal environments.	Yes
<b>Time Mark Pulse (1PPS)</b>	A timing pulse generated every second the receiver is in a valid navigation state (5 SVs required for initial pulse start-up).	Yes
<b>MEMS</b>	3-axis accelerometer support for static detection and wake-up. 3-axis magnetometer support for compass heading.	A
<b>3 Day CGEE</b>	AGPS using prediction of ephemeris from live (downloaded from satellites), ephemeris stored in memory.	Yes
<b>14 Day SGEE</b>	AGPS using server-generated extended ephemeris is now compatible with 14-day prediction files available from the server. These files can be saved EEPROM or host memory.	A



<b>Adaptive Jammer Detection</b>	System scan for up to 8 CW jammers for removal by the GPS.	Yes
<b>2.4GHz Notch Filter</b>	System can reject 2.4GHz signals at the antenna port input up to 50dB attenuation.	Yes
<b>Fast Time-Sync</b>	Determine time quickly from the GPS satellites and then stop receiving satellites.	A
<b>Almanac Based Positioning</b>	Allows fast cold starts TTFF 22 s. typ. based on factory set (or broadcast or pushed) Almanac data.	A
<b>SPI Flash Support</b>	Supports 2 and 4 Mb SST and EON SPI flash devices. uses flash memory for storage of almanac, EE, data logging, crystal and XO temperature models and patch code.	A
<b>Data Logging</b>	The embedded data logging function is configurable and will save data on either parallel or SPI flash.	A
<b>GPIO Baud Rate and Protocol Detection</b>	Baud rate and protocol selection can be set upon start up through GPIO0 and GPIO1 configuration.	Yes
Yes = always enabled                      A = available, but not enabled by default		



! " ! " # \$ % & \$\$ ' ( % ) " \* ' ) 3 +

3' ,

SE880 is available as 34 pins LGA package in 4.7 x 4.7 mm. Soldering pads are in 0.4mm pitch. Pin functions are shown in Table 6.

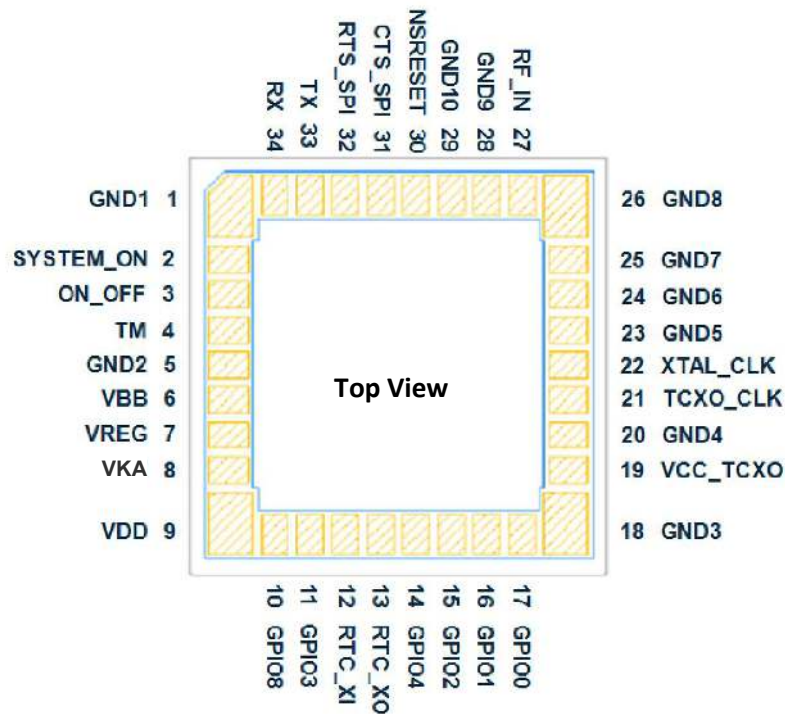

3' , ,

Pad Number	Pad Name	Type	Description
1	GND1	PWR	GROUND
2	SYSTEM_ON	O	Indication that GPS is running (Active high)
3	ON_OFF	I	Input signal turns GPS ON or OFF (Active high pulse)
4	TM	O	1PPS time mark pulse
5	GND2	PWR	GROUND
6	VBB_I	PWR	Core digital supply 1.2V typ.
7	VREG_O	PWR	1.2V output of internal regulator





8	VKA	PWR	1.8v keep alive input for I/O and internal blocks
9	VDD	PWR	Main supply voltage, 1.8V (ALWAYS ON)
10	GPIO8	I/O	General Purpose Input/Output
11	GPIO3	I/O	General Purpose Input/Output
12	RTC_XI	CLK	RTC crystal or CMOS RTC clock input
13	RTC_XO	CLK	RTC crystal or open if no crystal
14	GPIO4	I/O	General Purpose Input/Output
15	GPIO2	I/O	General Purpose Input/Output
16	GPIO1	I/O	<ul style="list-style-type: none"> <li>• Baud Rate and Protocol Detection</li> <li>• General Purpose Input/Output</li> </ul>
17	GPIO0	I/O	<ul style="list-style-type: none"> <li>• Baud Rate and Protocol Detection</li> <li>• General Purpose Input/Output</li> </ul>
18	GND3	PWR	GROUND
19	VCC_TCXO	PWR	TCXO voltage supply
20	GND4	PWR	GROUND
21	TCXO_CLK	CLK	RF reference clock input; TCXO input or bare crystal output connection for built-in XO option
22	XTAL_CLK	CLK	Bare crystal input connection for built-in XO option or open for TCXO
23	GND5	PWR	GROUND
24	GND6	PWR	GROUND
25	GND7	PWR	GROUND
26	GND8	PWR	GROUND
27	RF_IN	I	GPS RF Input (3V DC max rating)
28	GND9	PWR	GROUND



! " ! " # \$ % & \$ \$ ' ( ' ( % ) " \* ' ) +

29	GND10	PWR	GROUND
30	NSRESET	I	GPS Reset (active low)
31	CTS_SPI	I/O	<ul style="list-style-type: none"> <li>• Host port boot strap</li> <li>• General Purpose Input/Output</li> </ul>
32	RTS_SPI	I/O	<ul style="list-style-type: none"> <li>• Host port boot strap</li> <li>• General Purpose Input/Output</li> </ul>
33	TX	O	UART/SPI/I2C (1.8V)
34	RX	I	UART/SPI/I2C (3.6V tolerant)



' , ) 7

' ' 9 %

Telit SE880 module has been designed in order to be compliant with a standard lead-free SMT process. For detailed information about PCB pad design and conditions in SMT process please refer to "SE880 HW User guide".

' ' 6 ) 7 \$

According to SMT process for pick & place movement requirements, Telit SE880 modules are packaged in Tape&Reel.  
Two different T&R are available:

- Hi-Capacity T&R : 4000 pcs each.
- Low-Capacity T&R: 500 pcs each

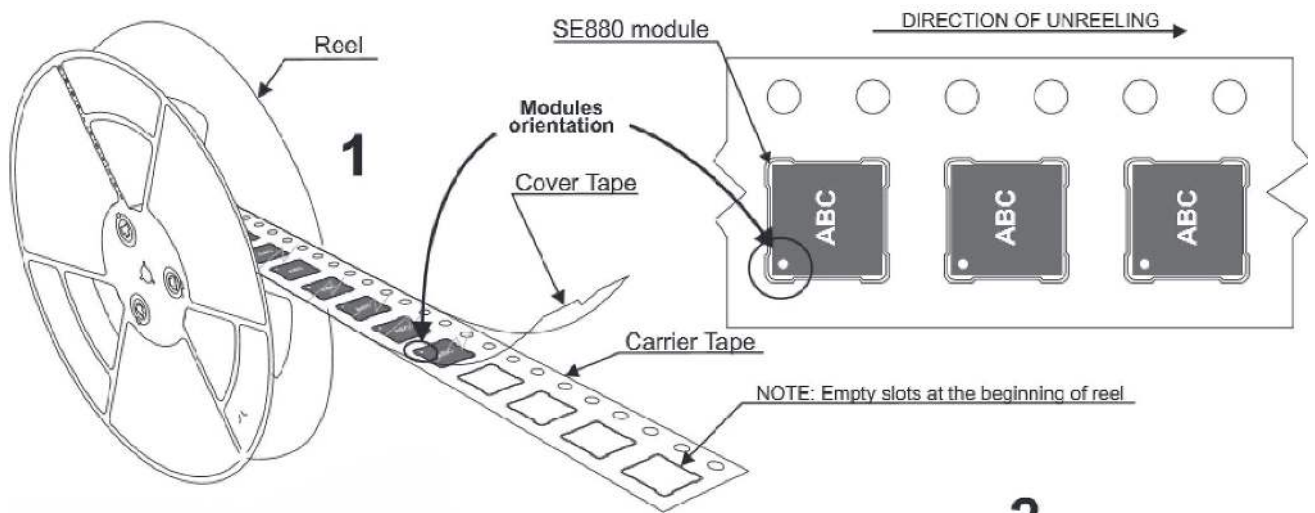

' & \$ 7 ( \$  
' , & % & \$ 7

## EC DECLARATION OF CONFORMITY

1. **SE880** (product name)

2. Telit Communications S.p.A - loc. Sa Illetta, S.S. 195, Km 2.300, 09122 Cagliari - ITALY (manufacturer)

3. This declaration of conformity is issued under the sole responsibility of the manufacturer

4. GPS Receiving Module

5. The object of the declaration described above is in conformity with the relevant Community harmonisation:  
European Directive 1999/05/EC (R&TTE)

6. The conformity with the essential requirements of the 1999/05/EC has been demonstrated against the following harmonized standards:

EN 60950-1:2006 + CORR.2006 + A11:2009 + A1:2010 + A12:2011 + AC:2011	For article 3.1 (a): Health and Safety of the User
EN 301 489-1 V1.9.2 EN 301 489-3 V1.4.1	For article 3.1 (b): Electromagnetic Compatibility
EN 300 440-1 V1.6.1 EN 300 440-2 V1.4.1	For article 3.2: Effective use of spectrum allocated

7. The conformity assessment procedure referred to in Article 10 and detailed in Annex V of Directive 1999/05/EC has been followed with the involvement of the following Notified Body:  
 CETECOM ICT Services GmbH Untertürkheimer Straße 6-10, D-66117 Saarbrücken, Germany.  
 Notified Body Number: 0682  
 Due to the equipment dimensions, the CE marking cannot be visibly and legibly affixed on the product itself.  
 Thus, **CE 0682** is affixed to the packaging, if it exists, and to the accompanying documents.

8. The Technical Construction File (TCF) relevant to the product described above, and which supports this Declaration of Conformity, is held at: Telit Communications S.p.A Via Stazione di Prosecco, 5/b 34010 Sgonico (TRIESTE) ITALY

Signed for and on behalf of Telit Communications S.p.A

Trieste, 2013-04-09

---

EMEA Quality Director  
Guido Walcher

---

Quality Manager  
Cesare Robelli

Technical Construction File : 304177CF0035a Rev.0



! " ! " # \$ % & \$ \$ ' ( ' ( % ) " \* ' ) + +

,

@AB \* % A

The SE880 Evaluation Kit is available to assist in the evaluation and integration of the module in custom applications. The Development Kit contains all of the necessary hardware and software to carry out a thorough evaluation of the module.

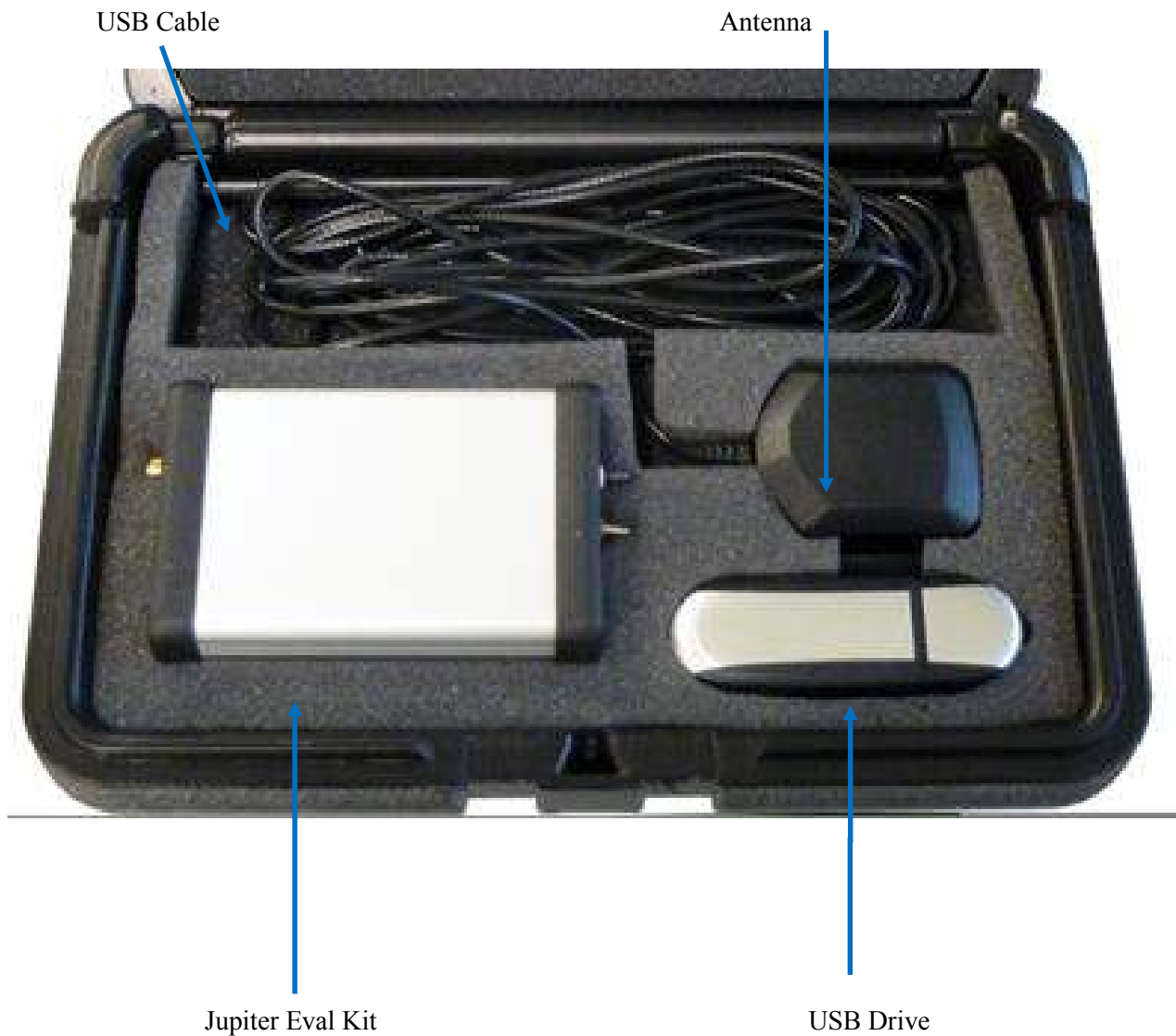



,

## AB ) A

While the SE880 EVK is intended to provide customer with the lab evaluation, so EVK needs to be connected to a PC, the SE880 Reference Design Kit is intended to provide customer with a tool to evaluate the SE880's performances when the Jupiter is mounted following Telit's Reference Design recommendations and using passive antennas.

SE880 Reference Design Kit is a plastic box containing SE880 mounter in a reference board with four passive antennas.

The box is a portable compact tool, manily intended for drive tests, allowing customer to switch among to 4 diffent patch passive antennas in order to test and understand device performances and customer needs.

See SE880 Reference Design Kit User Guide for details (TBC).



! " ! " # \$ % & \$\$ ' ( % ) " \* ' ) + +



, 7 \$ \$

**READ CAREFULLY**

Be sure the use of this product is allowed in the country and in the environment required. The use of this product may be dangerous and has to be avoided in the following areas:

- Where it can interfere with other electronic devices in environments such as hospitals, airports, aircrafts, etc.
- Where there is risk of explosion such as gasoline stations, oil refineries, etc. It is responsibility of the user to enforce the country regulation and the specific environment regulation.

Do not disassemble the product; any mark of tampering will compromise the warranty validity. We recommend following the instructions of the hardware user guides for a correct wiring of the product. The product has to be supplied with a stabilized voltage source and the wiring has to be conforming to the security and fire prevention regulations. The product has to be handled with care, avoiding any contact with the pins because electrostatic discharges may damage the product itself. Same cautions have to be taken for the SIM, checking carefully the instruction for its use. Do not insert or remove the SIM when the product is in power saving mode.

The system integrator is responsible of the functioning of the final product; therefore, care has to be taken to the external components of the module, as well as of any project or installation issue. Should there be any doubt, please refer to the technical documentation and the regulations in force. Every module has to be equipped with a proper antenna with specific characteristics. The antenna has to be installed with care in order to avoid any interference with other electronic devices.

The European Community provides some Directives for the electronic equipments introduced on the market. All the relevant information's are available on the European Community website:

<http://ec.europa.eu/enterprise/sectors/rtte/documents/>

The text of the Directive 99/05 regarding telecommunication equipments is available, while the applicable Directives (Low Voltage and EMC) are available at:

<http://ec.europa.eu/enterprise/sectors/electrical/>



! " ! " # \$ % & \$ \$ ' ( % ) " \* ' ) ++ +

, \$ < 7

Revision	Date	Changes
Preliminary 0	2012-10-30	First Preliminary issue
R1	2013-01-15	§3.2.1 updated Navigation sensitivity Deleted §3.2.3 : Dinamic constraints §5.7 updated pin-out
R2	2014-06-10	Added comformity assessment chapter. Updated packaging chapter



! " ! " # \$ % & \$ \$ ' ( % ) " \* ' ) + +