

## 12A, 22V, Step Down Power Module

### Description

The LX9610 is a 22V, 12A Power Module designed for step down point of load applications. This device includes a synchronous controller with compensation built-in, internal power MOSFETs, and the output inductor all in a 15mm x 15mm QFN package. It will operate with an input voltage from 8V to 22V, while the output voltage is adjustable from 0.8V to 5V, using a single external resistor. Included is an internal 5V regulator, and the only other components needed to make a complete 12A DC to DC converter are a 4.7 $\mu$ F decoupling capacitor for the 5V regulator, and the bulk input and output capacitors.

Other features of this device are internal digital soft start, thermal shutdown and hiccup mode current limit. The device can be enabled or shut down through the COMP/EN pin. Over current sensing is accomplished by measuring the voltage across the Rds-on of the low-side MOSFET.

Current of the OCP pin of the IC multiplied by resistance of the OCP resistor (residing on the PCB inside the module) sets the OCP threshold. An external resistor can be used to reduce the OCP threshold.

The LX9610 is package in a thermal enhanced, compact over-molded module with a length, width and height of the power module are 15mm, 15mm and 4mm, respectively. This package is suitable for assembly by standard automated surface mount equipment.

### Features

- Fully integrated 12A Power Module Requiring Only Input/output Caps and Few External Components
- Operational Input Supply Voltage Range: 8V to 22V
- Adjustable Output from 0.8V to 5V Using One External Resistor
- Integrated Upper and Lower N-Channel MOSFET's
- Maximum 1MHz Switching Frequency (Preset frequency is 600kHz)
- Can be Enabled or Shut Down Through the COMP/EN pin
- Internal Digital Soft Start
- Cycle-by-cycle Over Current Monitoring with Hiccup mode protection
- Available in QFN 15mm x 15mm x 4mm
- RoHS Compliant & Halogen Free

### Applications

- Set-top Box
- Servers
- Industrial Equipments
- Telecom and Datacom Applications
- Point of Load Regulator Applications
- Gaming

### Product Highlight

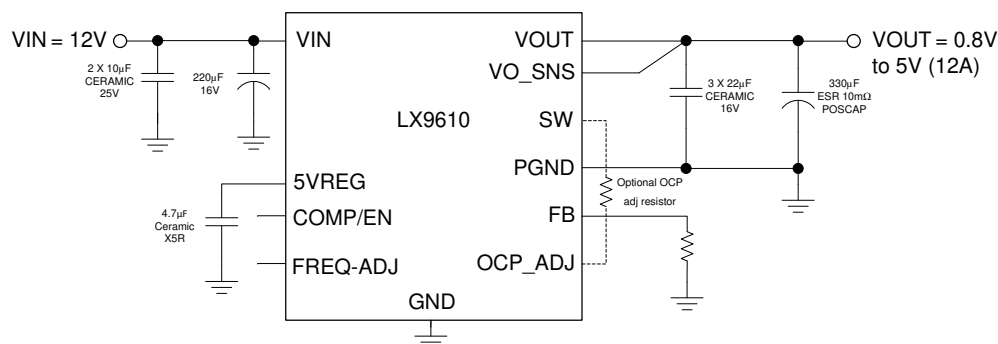
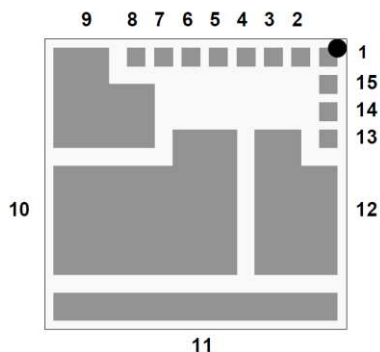


Figure 1 · Product Highlight

## Pin Configuration



**Figure 2** · Pinout (Top View)

Top mark



- MSC
  - LX9610
- YYWWA = Year/Week/Lot Identifier

## Ordering Information

Ambient Temperature	Type	Package	Part Number	Packaging Type
-40°C to 85°C	RoHS2 compliant, Pb-free Matte Sn lead finish MSL 3	QFN 15 x 15 x 3.75 15L	LX9610ILQ	Tube
			LX9610ILQ -TR	Tape and Reel

## Pin Description

Pin Number	Pin Designator	Description
1, 2, 3, 4	GND	These pins are connected to the GND pin of the controller IC. Connect the external controller components to these pins for ground connection.
5	5VREG	The output of the internal 5V regulator. A 4.7µF ceramic cap must be connected from this pin to GND.
6	VO_SNS	This pin is connected to the VOUT at the regulation point of the load.
7	Unused	NC, this pin is not used.
8	OCP_ADJ	A resistor between this pin and SW pin adjusts the OCP threshold down.
9	VIN	Power input pin of the module. Connect a low ESR bulk capacitor from this pin to GND to have low ripple voltage at this pin.

Pin Number	Pin Designator	Description
10	SW	Switch node pin. The high-side and low-side MOSFET's and the inductor are connected to this pin. If needed, connect an R-C snubber network from this pin to GND to limit the voltage spike at this to 30V (max).
11	PGND	Power ground pin. Connect the input and output bulk caps to this pin for ground connection. This pin needs to be connected to GND pins on the application PCB.
12	VOUT	Output terminal of the power module. Connect a 330 $\mu$ F POSCAP in parallel with three 22 $\mu$ F ceramic caps from this pin to PGND pin.
13	COMP/EN	This is the output of the transconductance error amplifier. Pulling this pin to ground shuts down the power module. Floating this pin enables the power module.
14	FB	Feedback pin. A resistor connected from this pin to GND sets the output voltage. Use the formula: $V_{OUT} = V_{FB} * (1 + 49.9k / R_{FB})$
15	FREQ-ADJ	Switching frequency adjustment pin. With this pin floating, the module will have a switching frequency of 600kHz. By connecting an external resistor from this pin to GND, the switching frequency can be increased. Maximum frequency allowed is 1MHz.

## Absolute Maximum Ratings

Parameter	Value	Units
Supply Input Voltage (VIN)	-0.3 to 25	V
Switch Node Voltage (SW)	-0.3 to 30	V
All Other Pins	-0.3 to 6.5	V
Operational Ambient Temperature	-55 to +125	°C
Storage Temperature Range	-65 to +150	°C
Peak Package Solder Reflow Temperature (40 seconds maximum exposure)	245	°C

Exceeding these ratings could cause damage to the device. All voltages are with respect to GND. Currents are positive into, negative out of specified terminal. These are stress ratings only and functional operation of the device at these or any other conditions beyond those indicated under "Recommended Operating Conditions" are not implied. Exposure to "Absolute Maximum Ratings" for extended periods may affect device reliability.

## Thermal Properties

Thermal Resistance	Typ	Units
$\theta_{JP}$ Junction to Pads	1.5	°C/W
$\theta_{JA}$ Junction to Ambient	8	

**Note:** Note: The  $\theta_{Jx}$  numbers assume no forced airflow. Junction Temperature is calculated using  $T_J = T_A + (PD \times \theta_{JA})$ . In particular,  $\theta_{JA}$  is a function of the PCB construction. The stated number above is for a four-layer board in accordance with JESD-51 (JEDEC) with thermal vias on VIN, SW, VOUT, and PGND pins. See PCB layout Guidelines, figure 21.

## Electrical Characteristics

Symbol	Parameter	Test Condition	Min	Typ	Max	Units	
Unless otherwise specified, the following specifications apply over the operating ambient temperature of $-40^{\circ}\text{C} \leq T_A \leq 85^{\circ}\text{C}$ except where otherwise noted with the following test conditions: $V_{\text{IN}} = 12\text{V}$ , $V_{\text{OUT}} = 1.2\text{V}$ , $C_{\text{IN}} = 220\mu\text{F} + 2 \times 10\mu\text{F}$ (ceramic), $C_{\text{OUT}} = 330\mu\text{F}$ , $\text{ESR} = 10\text{m}\Omega + 3 \times 22\mu\text{F}$ ceramic capacitors. Typical parameter refers to $T_J = 25^{\circ}\text{C}$							
<b>Operating Current</b>							
I <sub>Q</sub>	Quiescent Current	I <sub>VOUT</sub> = 0A, V <sub>OUT</sub> = 5V, V <sub>IN</sub> = 12V		75		mA	
I <sub>SHDN</sub>	Shutdown Supply Current	V <sub>COMP/EN</sub> = 0V	3.7	4.8	11	mA	
<b>VIN UVLO</b>							
V <sub>UVLO</sub>	Under Voltage Lockout	V <sub>IN</sub> Rising	6	6.5	7.5	V	
V <sub>HYS</sub>	UVLO Hysteresis			0.6		V	
<b>FD</b>							
V <sub>FB</sub>	Feedback Voltage		0.784	0.8	0.816	V	
<b>Oscillator</b>							
F <sub>OSC</sub>	Internal Oscillator Frequency	FREQ-ADJ pin = floating, open		600		kHz	
		FREQ-ADJ pin = 20kΩ to GND		930			
D <sub>MAX</sub>	Maximum Duty Cycle	V <sub>FB</sub> = 0.7V, FREQ-ADJ pin = floating, open	80	83	86	%	
TON <sub>MIN</sub>	Minimum On Time	V <sub>FB</sub> = 1V			150	ns	
<b>COMP/EN</b>							
G <sub>EA</sub>	Error Amplifier Transconductance	1V ≤ V <sub>COMP/EN</sub> ≤ 4V; GBD	1.35	1.85	2.35	mA/V	
	COMP/EN Shut Down Threshold	GBD	0.14	0.2	0.26	V	
<b>Output</b>							
ΔV <sub>OUT,LINE</sub>	Line Regulation	I <sub>VOUT</sub> = 0.5A, 8V < V <sub>IN</sub> < 22V		0.1		%	
ΔV <sub>OUT,LOAD</sub>	Load Regulation	V <sub>IN</sub> = 12V, 0A < I <sub>VOUT</sub> < 12A, GBD		0.013		%/A	
R <sub>DS,ONL</sub>	Low-side Switch On Resistance	I <sub>SW</sub> = 1A (current coming out of SW)		7	9	mΩ	
I <sub>LEAK-SW</sub>	SW Pin Leakage Current	V <sub>O_SNS</sub> Open		1.14		mA	
<b>Soft Start</b>							
T <sub>SS</sub>	Soft Start Time			1.7		ms	
T <sub>HICCUP</sub>	Hiccup Time	V <sub>IN</sub> =12V, GBD		7.3		ms	
<b>Protection</b>							
V <sub>FB,UV</sub>	Output Under Voltage Protection Threshold	OCP_ADJ pin floating	0.54	0.6	0.66	V	
	OCP Threshold for Output Current	GBD	13.6	23.6	28.5	A	
T <sub>OTSD</sub>	Thermal Shutdown Threshold				155		°C
T <sub>HYS</sub>	Thermal Shutdown Hysteresis				21		
<b>5VREG</b>							
	5VREG Voltage Range	I <sub>5VREG</sub> = 5mA	4.875	5.125	5.325	V	
	5VREG UVLO	5VREG voltage rising, GBD		4.04		V	
	5VREG UVLO Hysteresis	GDB		0.28		V	
	5VREG Max Current	8V ≤ V <sub>IN</sub> ≤ 22V	20	50		mA	
GBD = Guaranteed by design, characterization, not production tested.							

# Simplified Schematic

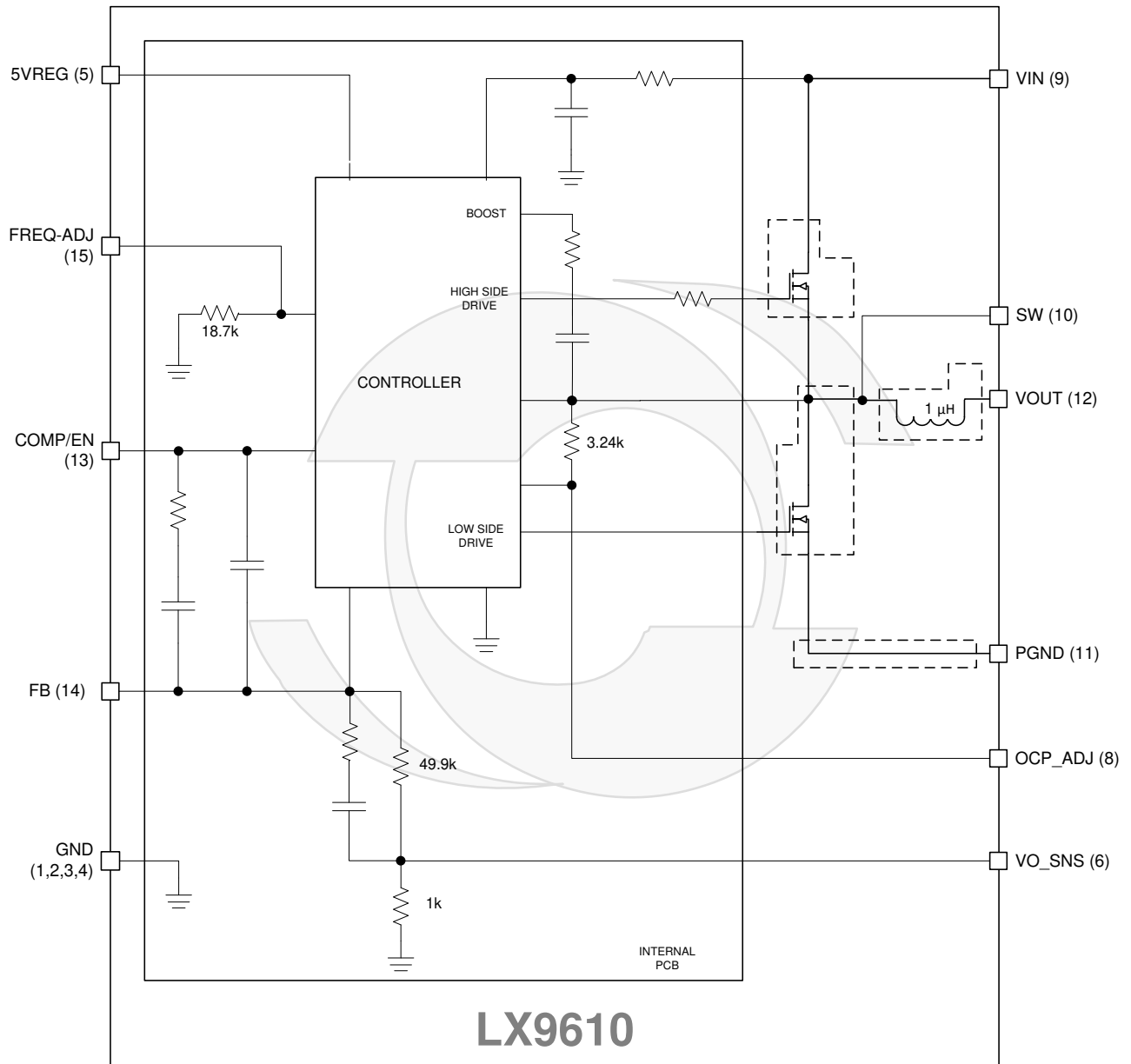
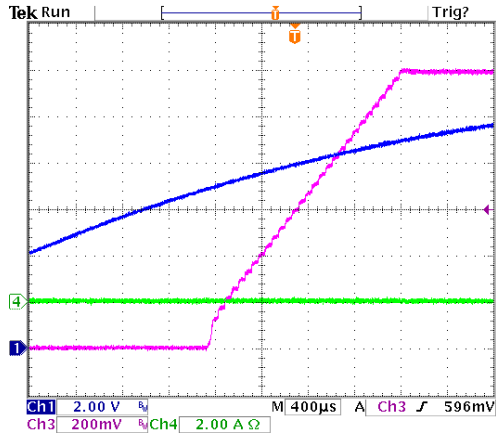
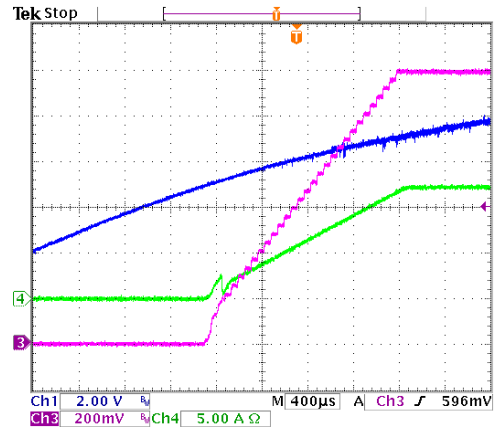


Figure 3 - LX9610 Simplified Schematic

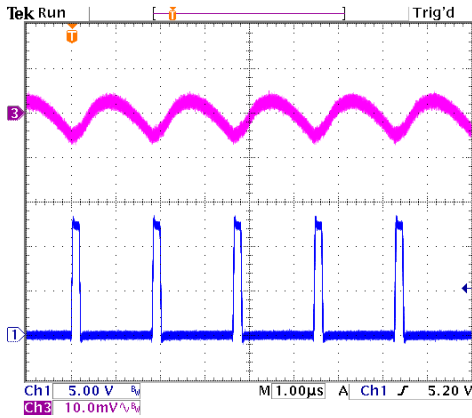
## Characteristic Curves – VIN = 12V, VOUT = 1.2V



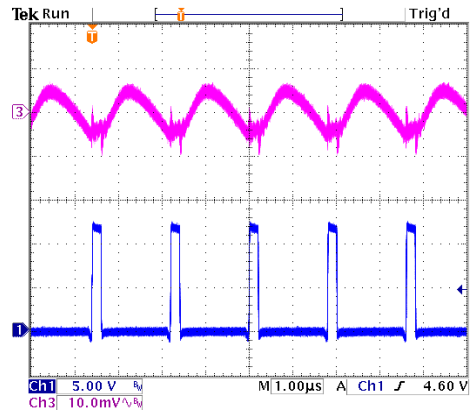
**Figure 4** · Startup No Load  
CH1 VIN, CH3 VOUT,  $R_{FB} = 100k\Omega$ , CH4 Load Current



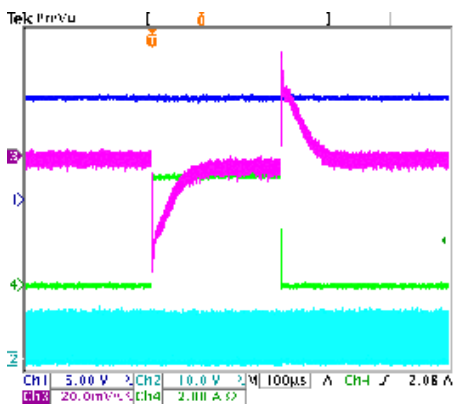
**Figure 5** · Startup 12A (Constant Current)  
CH1 VIN, CH3 VOUT,  $R_{FB} = 100k\Omega$  CH4 Load Current



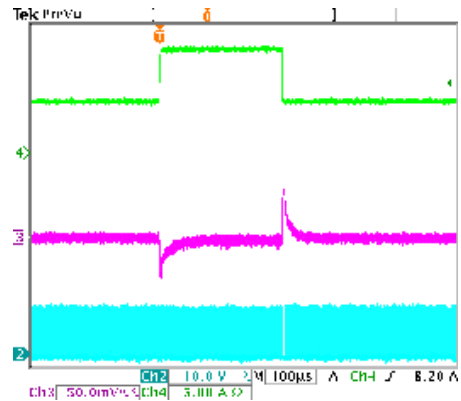
**Figure 6** · Output Ripple, No Load  
CH1 Switch Node Voltage, CH3 VOUT (AC coupled across Ceramic Output Capacitors)



**Figure 7** · Output Ripple, 12A Load  
CH1 Switch Node Voltage, CH3 VOUT (AC coupled across Ceramic Output Capacitors)

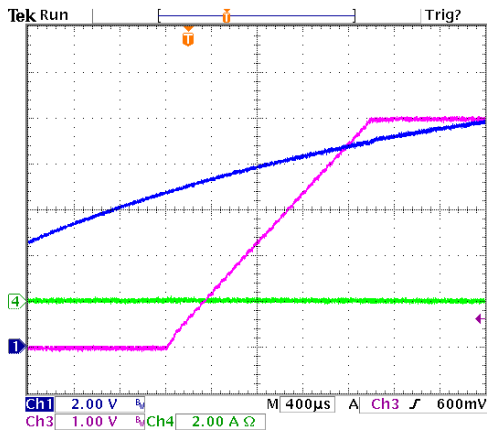


**Figure 8** · Transient Response 0A to 5A ( $5A/\mu s$ )  
CH1 VIN, CH2 Switch Node Voltage, CH3 VOUT (AC coupled across Ceramic Output Capacitors), CH4 Load Current

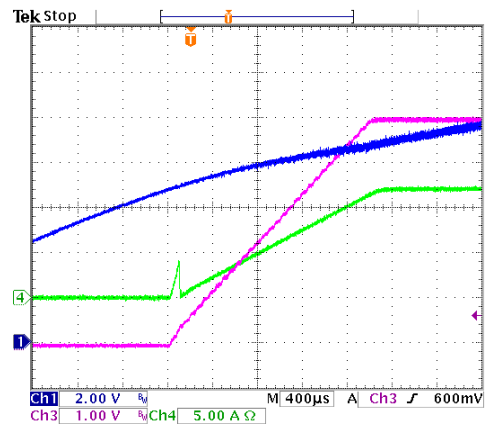


**Figure 9** · Transient Response 6A to 12A ( $5A/\mu s$ )  
CH2 Switch Node Voltage, CH3 VOUT (AC coupled across Ceramic Output Capacitors), CH4 Load Current

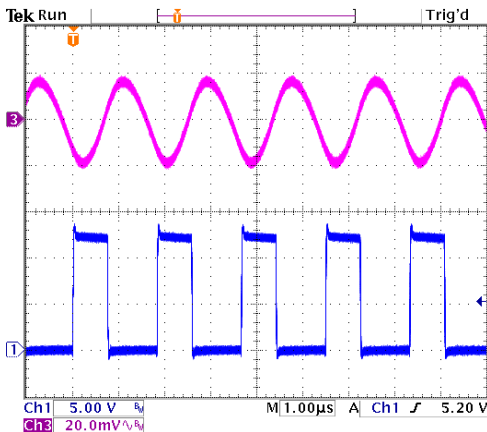
# Characteristic Curves – VIN = 12V, VOUT = 5V



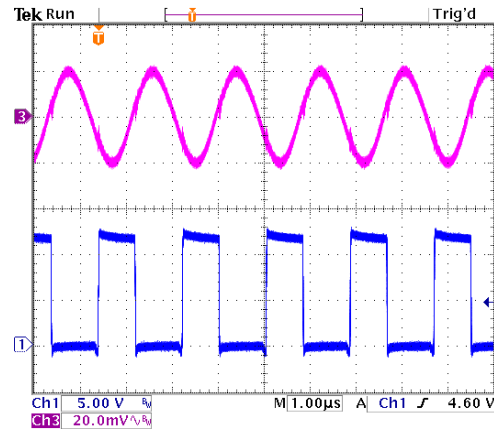
**Figure 10** · Startup No Load  
CH1 VIN, CH3 VOUT, R<sub>FB</sub> = 9.53kΩ, CH4 Load Current



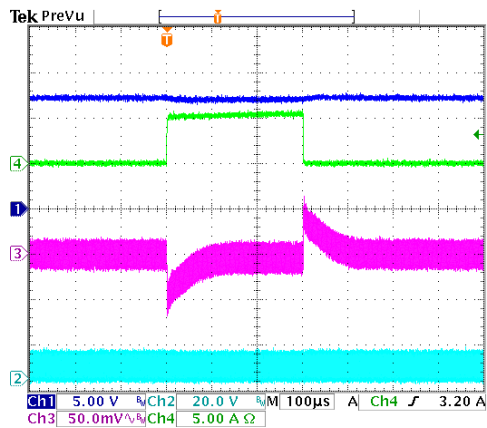
**Figure 11** · Startup 12A (Constant Current)  
CH1 VIN, CH3 VOUT, R<sub>FB</sub> = 9.53kΩ, CH4 Load Current



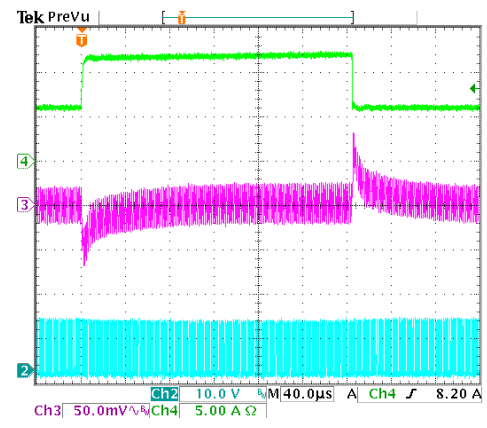
**Figure 12** · Output Ripple, No Load  
CH1 Switch Node Voltage, CH2 VOUT (AC coupled across ceramic output capacitors)



**Figure 13** · Output Ripple, 12A Load  
CH1 Switch Node Voltage, CH2 VOUT (AC coupled across ceramic output capacitors)

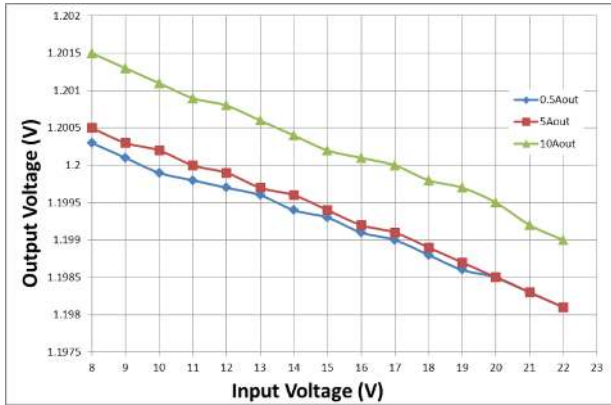


**Figure 14** · Transient Response 0A to 5A (5A/μs)  
CH1 VIN, CH2 Switch Node Voltage, CH3 VOUT (AC coupled across ceramic output capacitors), CH4 Load Current

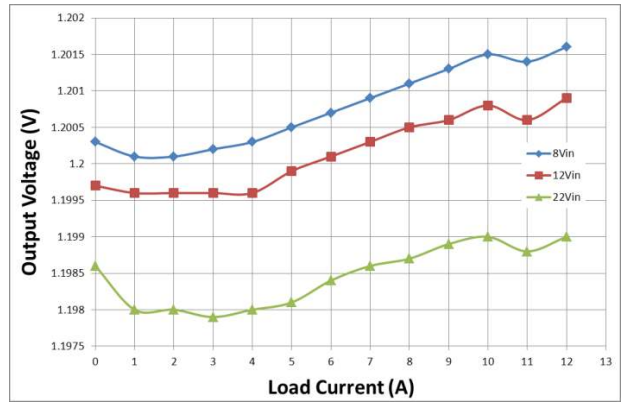


**Figure 15** · Transient Response 6A to 12A (5A/μs)  
CH2 Switch Node Voltage, CH3 VOUT (AC coupled across ceramic output capacitors), CH4 Load Current

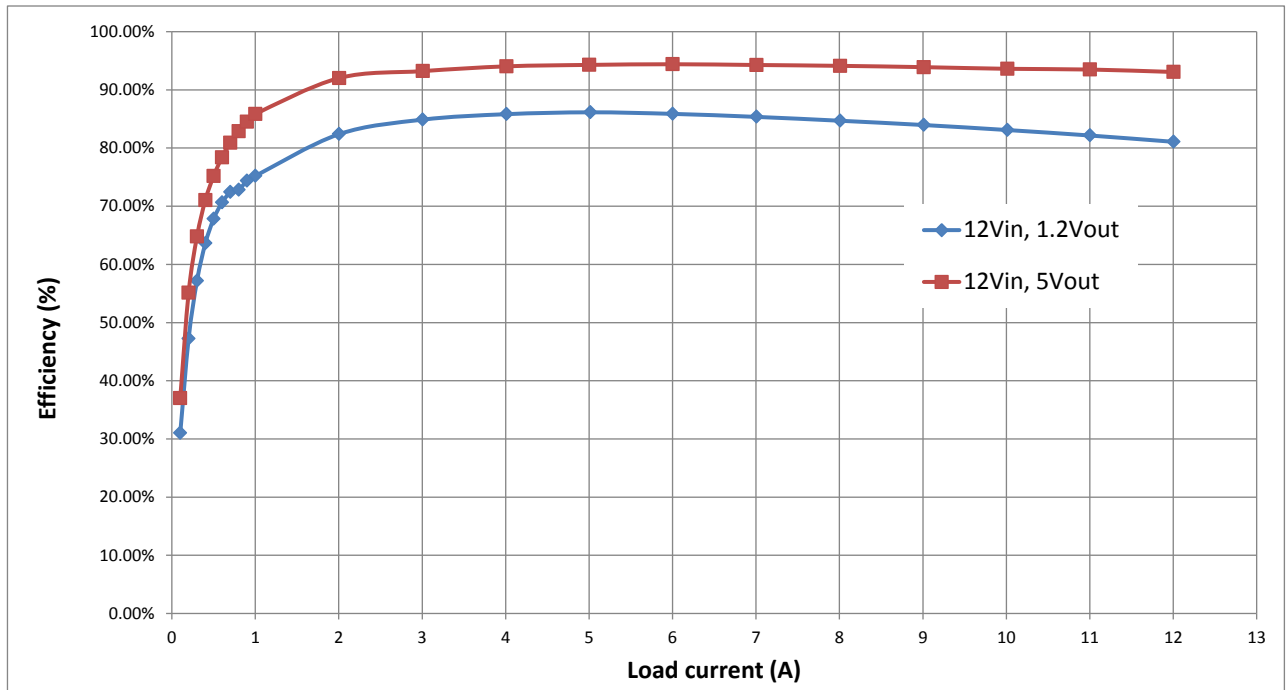
## Characteristic Curves



**Figure 16** · Line Regulation  
 $V_{OUT} = 1.2V$ ,  $I_{OUT} = 5A$



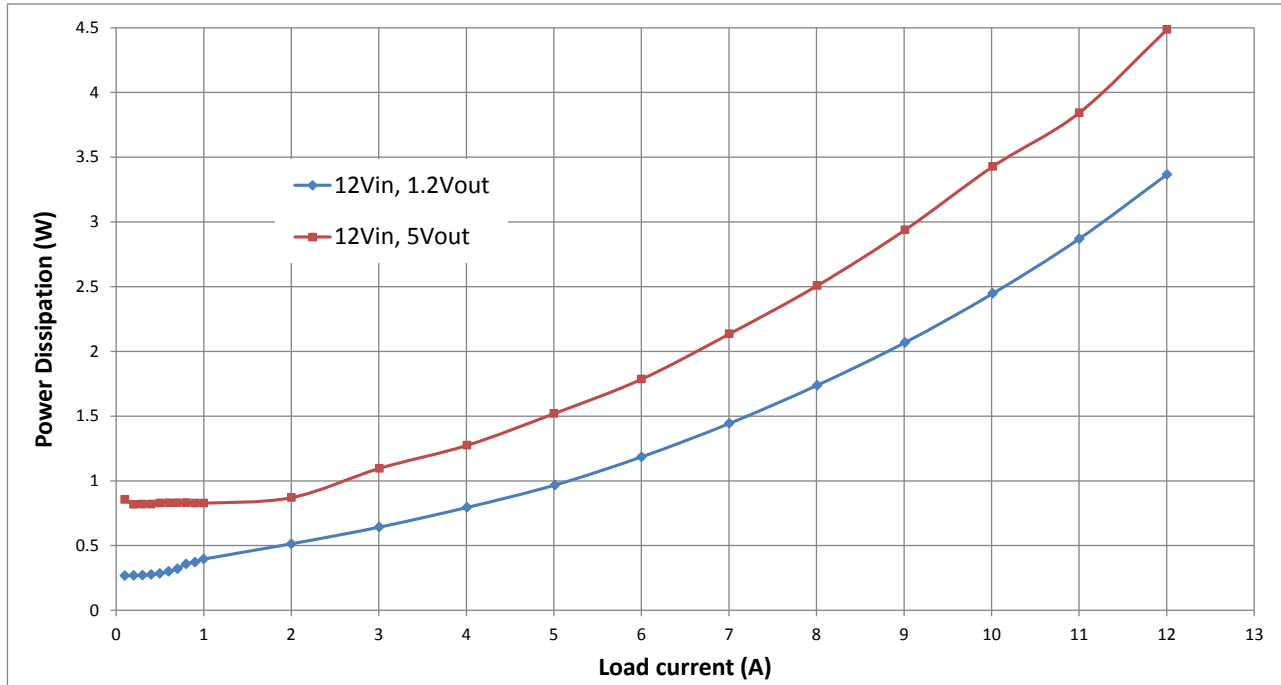
**Figure 17** · Load Regulation  
 $V_{OUT} = 12V$ ,  $V_{IN} = 8V, 12V, 22V$



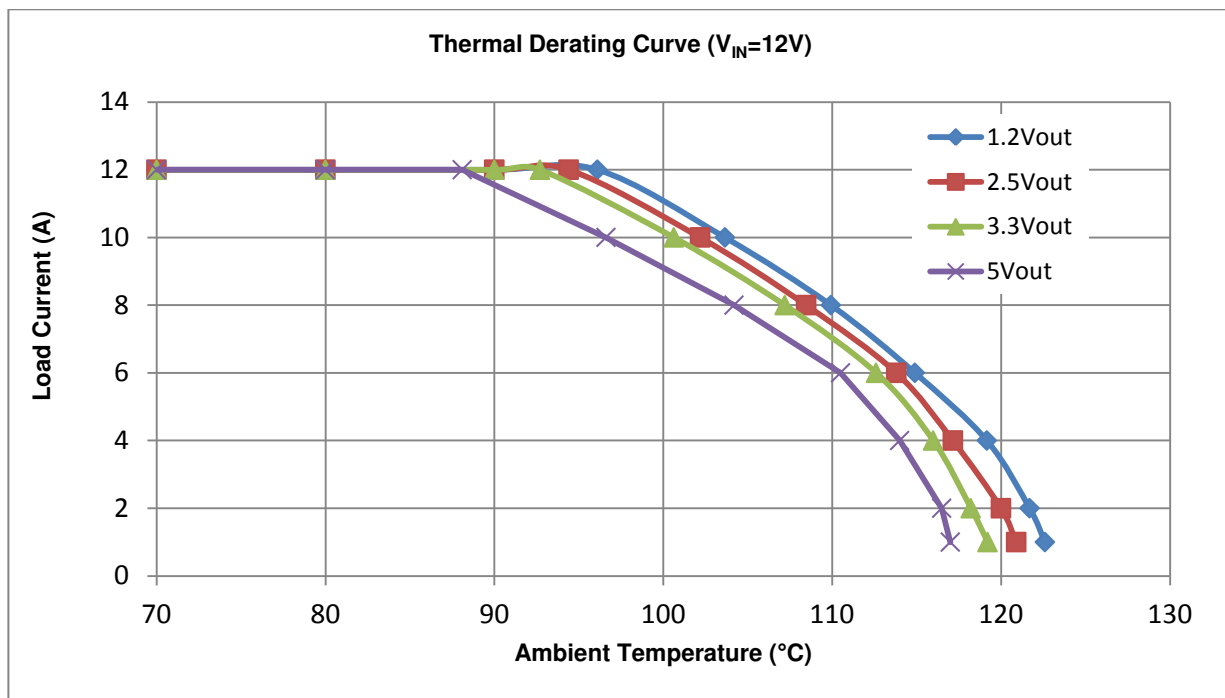
**Figure 18** · Efficiency Measurements  
 $V_{IN} = 12V$ ,  $V_{OUT} = 1.2V$  and  $5V$



## Characteristic Curves



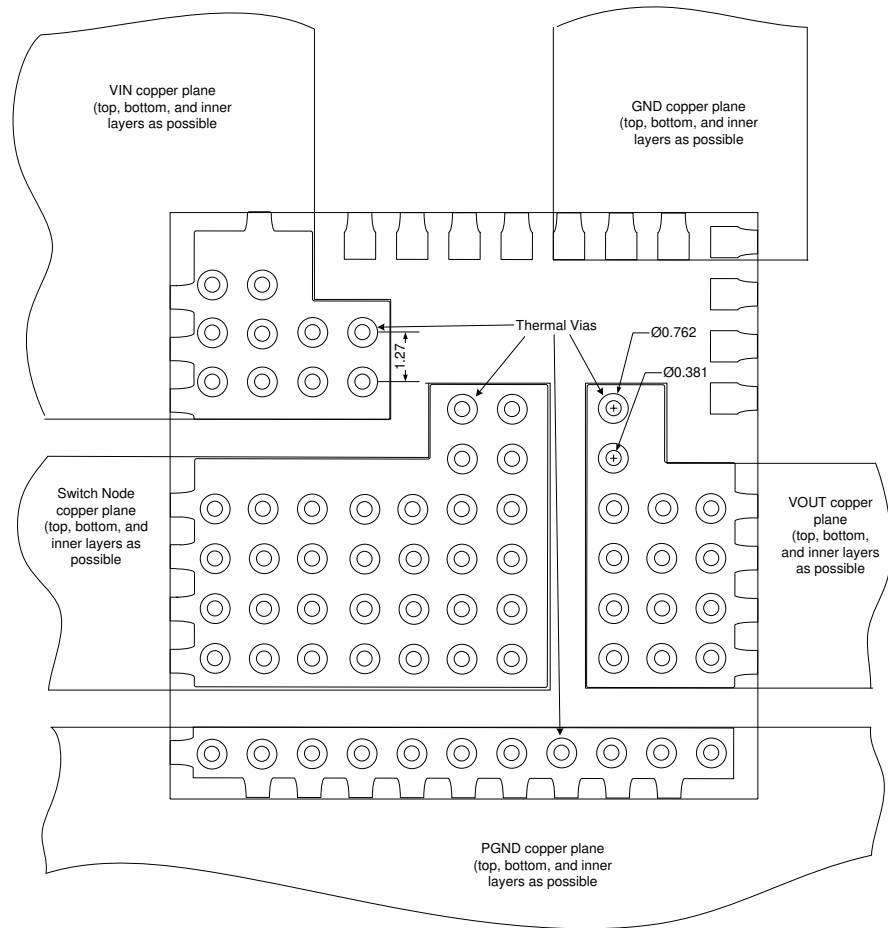
**Figure 19** · Power Dissipation Measurements  
VIN = 12V, VOUT = 1.2V and 5V



**Figure 20** · Thermal Derating Curve (VIN = 12V)

Thermal performance shown requires use of thermal vias on all power components and large copper planes.

## PCB Layout Guidelines



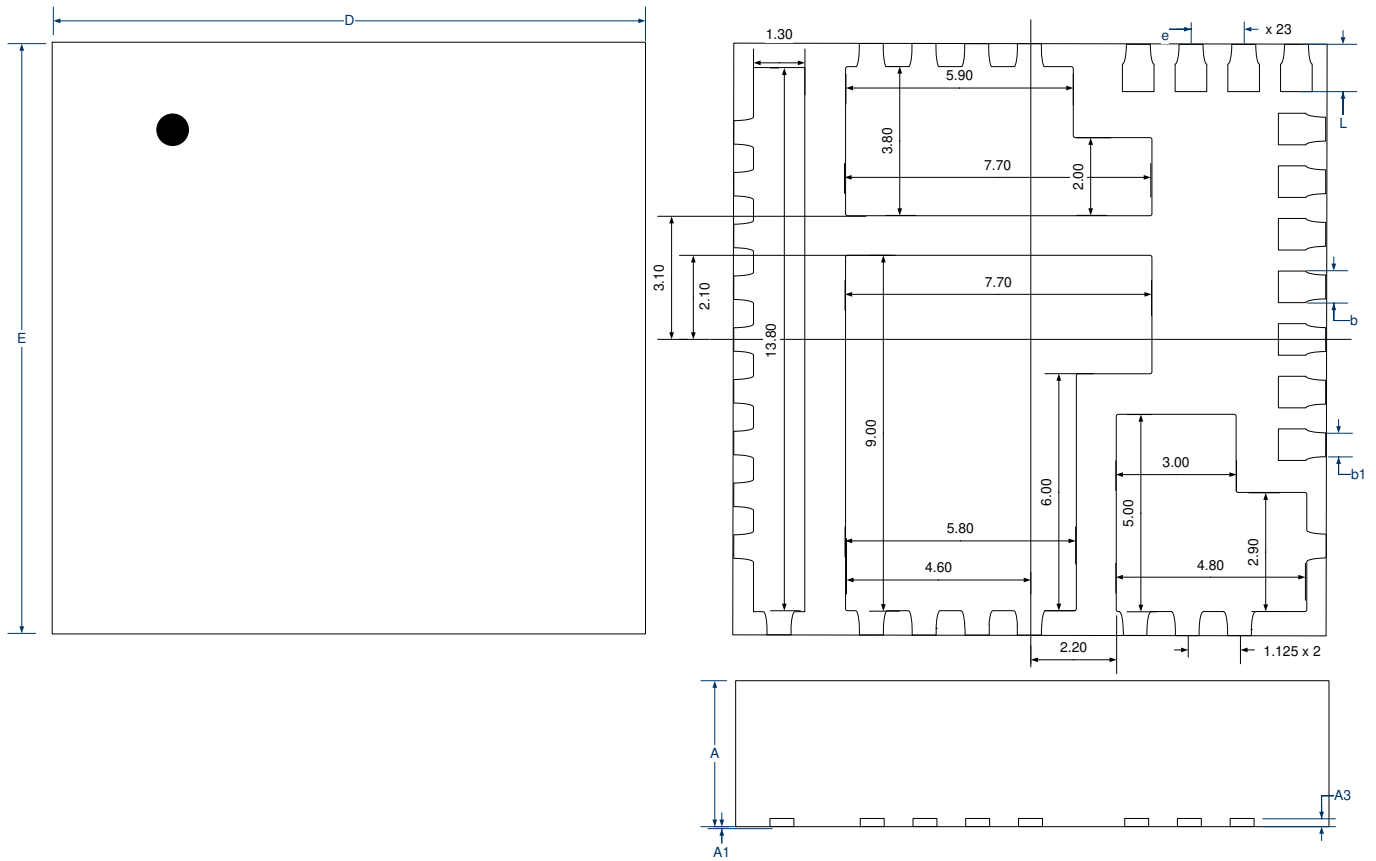
**Figure 21** - PCB Footprint with Thermal Vias

**Notes:**

1. Thermal via diameter 0.762 mm, hole diameter 0.381, spacing is 1.27mm
2. Recommended tented thermal vias as shown with vias filled with solder.
3. Aperture design for thermal pads using multiple openings with 60 to 80% solder paste coverage.
4. For best thermal performance maximize plane size and include copper planes on inner layers.
5. For additional layout details see the LX9610 Evaluation Board User Guide.

# Package Outline Dimensions

The package is halogen free and meets RoHS2 and REACH standards.



Dim	MILLIMETERS		INCHES	
	MIN	MAX	MIN	MAX
A	3.85	4.00	0.151	0.158
A1	0	0.05	0	0.002
A3	0.203 REF		0.008 REF	
b	0.75	0.85	0.030	0.033
D	15.00 BSC		0.591 BSC	
E	15.00 BSC		0.591 BSC	
b1	0.45	0.55	0.018	0.022
e	1.30 BSC		0.051 BSC	
L	1.15	1.25	0.045	0.049

### Note:

Dimensions do not include mold flash or protrusions; these shall not exceed 0.155mm (.006") on any side. Lead dimension shall not include solder coverage.

All dimensions are  $\pm 0.50\text{mm}$  unless otherwise noted.

Figure 22 · Package Dimensions



**Microsemi Corporate Headquarters**  
One Enterprise, Aliso Viejo CA 92656 USA  
Within the USA: +1 (949) 380-6100  
Sales: +1 (949) 380-6136  
Fax: +1 (949) 215-4996

Microsemi Corporation (NASDAQ: MSCC) offers a comprehensive portfolio of semiconductor solutions for: aerospace, defense and security; enterprise and communications; and industrial and alternative energy markets. Products include high-performance, high-reliability analog and RF devices, mixed signal and RF integrated circuits, customizable SoCs, FPGAs, and complete subsystems. Microsemi is headquartered in Aliso Viejo, Calif. Learn more at [www.microsemi.com](http://www.microsemi.com).

© 2013 Microsemi Corporation. All rights reserved. Microsemi and the Microsemi logo are trademarks of Microsemi Corporation. All other trademarks and service marks are the property of their respective owners.