

IMPUL-MATE* CONNECTOR

インパルメイトコネクタ

Contents

First 9 pages following this top sheet : English version
Next 9 pages : Japanese version

When only one of above versions is supplied to customers, this top sheet shall be attached.

目次

このシートに続く最初の9ページ : 英語版
次の9ページ : 日本語版

カスタマーに英語または日本語版の片方のみを提出する場合は、このトップシートが必ず添付されなければならない。

Revision Record (改訂記録)

Revision Letter (改訂記号)	EC number (改訂記録番号)	Date (日付)
A1	FJ00-1556-00	27 SEP 2000

Outline of the latest revision (最新改訂の概要)

Combine two language versions into one document. No change was made on product specification. Change document number to current format.

2ヶ国語の文書を一括管理とした。仕様内容に変更なし。



Tyco Electronics AMP K.K.
Kawasaki, Japan

Impul-Mate* Connector

411-5722

INSTRUCTION SHEET

Released	29 May '95
Rev-A	2751100

1. Introduction, part numbers and descriptions :

Impul-Mate* Connectors have been developed to provide automotive harness wiring, comprising the parts groups shown in Fig. 1, being available in 120, 104, 88, 76, 64 and 48 contact position connectors.

Product Descriptions	AMP Part Nos.	Nissan's Parts Names	Nissan's P/N
120 Pos. Male Housing Ass'y	917940-1	TK108-TAS12 HW	24347 70F60
104 Pos. Male Housing Ass'y	2-178079-6	TK68-TAS36 HGY	24347 70F20
88 Pos. Male Housing Ass'y	2-178078-6	TK58-TAS30 HW	24347 70F15
76 Pos. Male Housing Ass'y	174385	J07 HL	24347 51E00
64 Pos. Male Housing Ass'y	174836	J06 HL	24347 51E01
48 Pos. Male Housing Ass'y	174831	J04 HL	24347 51E02
120 Pos. Female Housing Ass'y	917937-1	TK108-TAS12 FW	24340 70F60
104 Pos. Female Housing Ass'y	178081-6	TK68-TAS36 FGY	24340 70F20
88 Pos. Female Housing Ass'y	178080-1	TK58-TAS30 FW	24340 70F15
76 Pos. Female Housing Ass'y	177700-1	TK60-TAS16 FW	24340 70F10
64 Pos. Female Housing Ass'y	177699-1	TK48-TAS16 FW	24340 70F05
48 Pos. Female Housing Ass'y	177698-1	TK40-TAS8 FW	24340 70F00
120 Pos. Wire Cover	917943-1	TK108-TAS12 COVER	24345 70F60
104 Pos. Wire Cover	178073-1	TK68-TAS36 COVER	24345 70F20
88 Pos. Wire Cover	178072-1	TK58-TAS30 COVER	24345 70F15
76 Pos. Wire Cover	177697-1	TK60-TAS16 COVER	24345 70F10
64 Pos. Wire Cover	177694-1	TK48-TAS16 COVER	24345 70F05
48 Pos. Wire Cover	177688-1	TK40-TAS8 COVER	24345 70F00
Bolt Case Ass'y	177653-2	BOLT-HLDR ASSY	24348 70F00

Fig. 1

(Contact)

Contact Type	Part Numbers	Applicable Wires	Number of Positions							
			120 Pos. 104 Pos. 88 Pos.	76 Pos. 64 Pos. 48 Pos.						
	Receptacle	Wire Type	0.3	0.5	0.85	1.25	2			
040 II	S	Sn 175265-1	CAVUS	○	○	○	×	×	○	○
		Au 175266-2	CAVS/AVSS	○	○	○	×	×		
		AVS	○	○	×	×	×			
070 II	S	Sn 175268-1	CAVUS	○	○	○	×	×	○	○
		Au 175275-2	CAVS/AVSS	○	○	○	×	×		
		AVS	○	×	×	×	×			
070 II	M	Sn 175269-1	CAVUS	×	×	×	○	×	○	○
		Au 175276-2	CAVS/AVSS	×	×	○	○	×		
		AVS	×	○	○	○	×			
070 II	M L	Sn 177654-1	CAVUS	×	×	×	○	×	○	×
		CAVS/AVSS	×	×	×	○	○			
		AVS	×	×	×	×	×			

Fig. 2

(1 / 9)

○ denotes applicable.

× denotes not applicable

2. Product Configuration

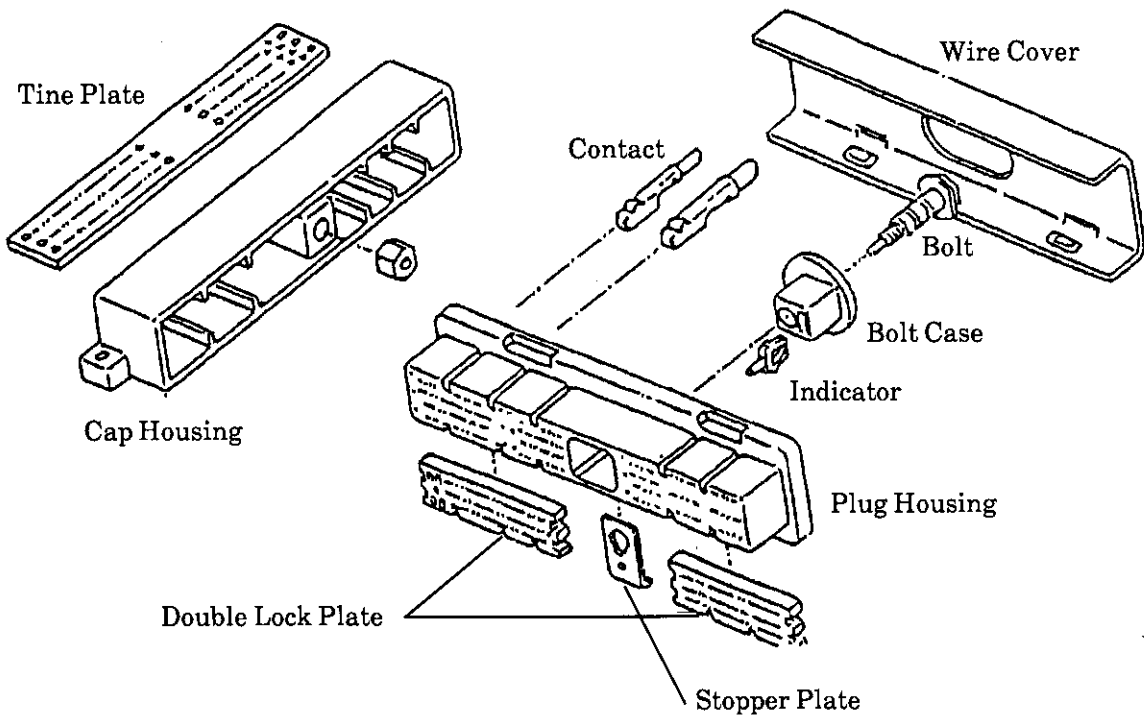

Fig. 3

3. Harness Assembly Operation :

3.1 Loading Wire-Crimped Contacts into Housing Cavities :

(1) Female Connector Assemblies :

P/N's 178081-6, 177700-1, 177698-1, 178080-1 and 177699-1

When to load wire-crimped contacts into housing cavities, be aware that you insert contact first with its tiny projection side facing to the retainer side of housing as shown in Fig. 4.

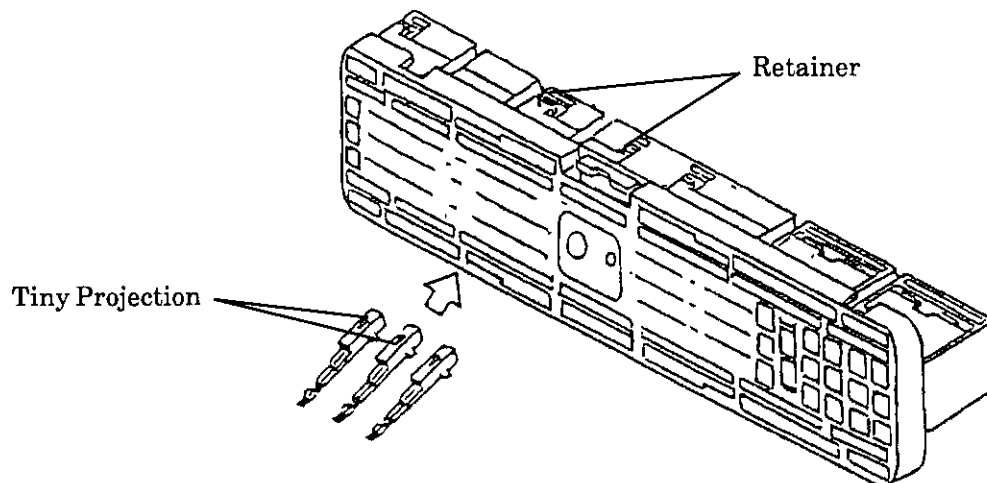

Fig. 4

3.2 Contact Loading Depth :

The loaded contacts must be inserted as far as it goes until it stops at the bottom of housing cavity.

When the contact reaches the bottom, a small clicking sound is heard, and it does not go any further to the depth. The contact engagement in the cavity is known by the sound.

To assure its full engagement in the cavity, just pull back the crimped wire lightly and confirm that the contact does not retract from the cavity.

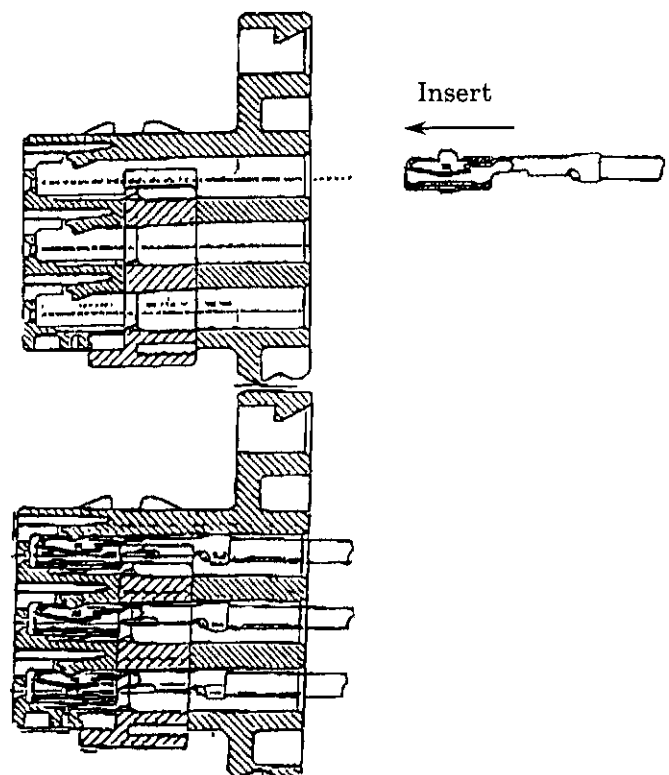

Fig. 5

3.3 Retainer Locking Methods : (Primary-Secondly locking)

The retainer of this connector system has been set in primary locking position as delivered to the customers.

After loading the wire crimped contacts in the connector cavities, according to the procedure shown in Para. 3.2, the retainer locking must be set in secondly locking position. The locking to the secondly position is done by depressing the retainer end as shown in Fig. 6 below.

At this moment, the contact inserted position has much to do with the retainer locking feasibility. If any of the contacts remain in half-inserted not reaching the bottom, the retainer secondly locking cannot be performed.

If the retainer secondly locking is not completed, make sure if all the contact insertion is fully bottomed in the cavities.

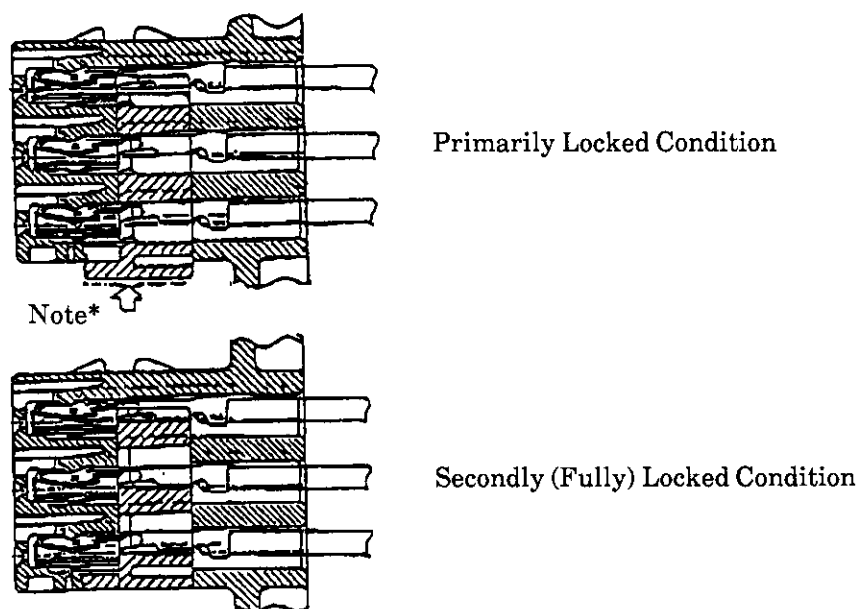

Note* Retainer should be pressed by hand lightly and made lock.

(If insertion force greater than 10 kgf, Retainer might be broken)

Fig. 6

3.4 Release of Retainer Locking (Return from Secondly Locking to Primary Locking Position) (120 Position, 104 Position, 88 Position)

When you need to remove contacts from the housing cavity, the retainer locking position must be in primary setting position. If the locking remains in the secondly locking position, contacts cannot be removed.

To return from the secondly position to primary position, use a screw-driver of 1.2 mm in width (a watchmaker's screw driver will be fitting.) to insert its tip end into the screw driver insertion hole as shown in Fig. 8 below.

In case the retainer locking position is not correctly obtained, return it to the secondly locking position, and repeat to return to the primary locking position with the use of watchmaker's screw-driver. (Fig. 7)

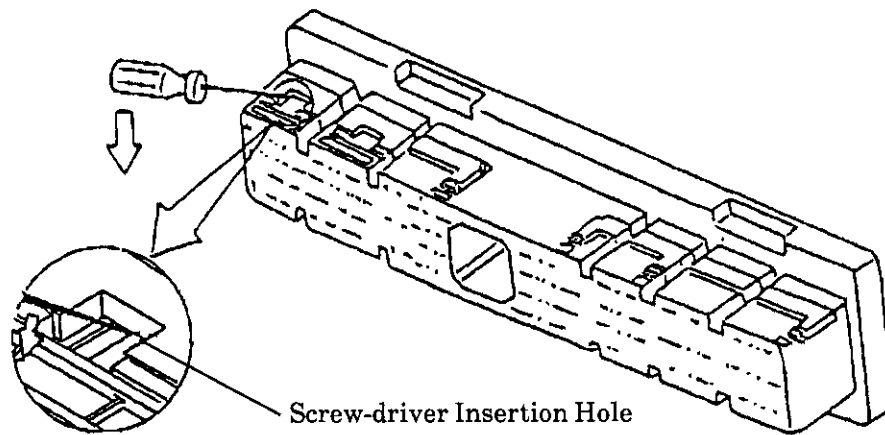
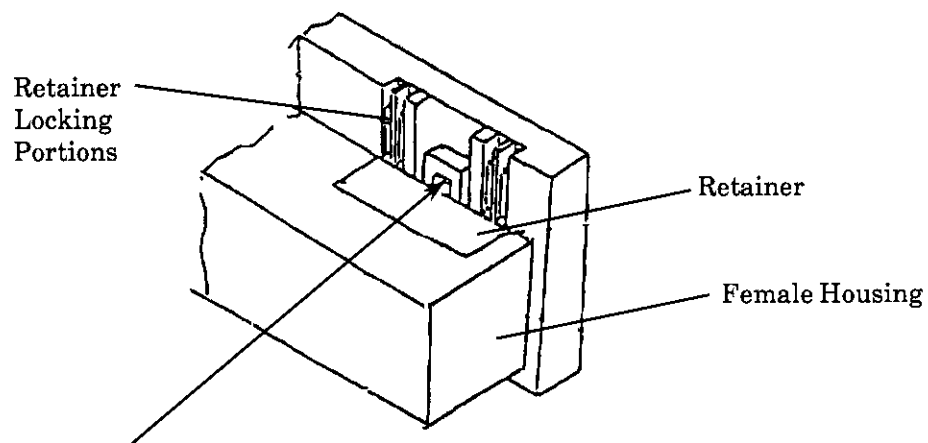

Fig. 7

Release of Retainer Locking from Secondly to Primary Position :
(For 76 Position, 64 Position and 48 Position Connectors) :



Insert tip end of the tool here, and pull up to unlock the retainer.

Fig. 8
(5 / 9)

3.5 Contact Removal from Housing Cavity :

3.5.1 Instructions to Contact Removal from Housing Cavities :

First, the retainer must be set in secondly locking position. (Refer to Para. 3.4.) With the retainer secondly position, no contact can be removed.

For contact extraction, use AMP Extraction Tool P/N 715131. The tip end of the extraction tool should be inserted in to the hole as shown in Fig. 9 horizontally.

The angle of tip end insertion should be carefully taken care of. If it is inserted rather downward, it will result in damage of the contact as shown in the bottom right sketch. Be sure to insert it horizontally as you see it in the bottom left sketch.

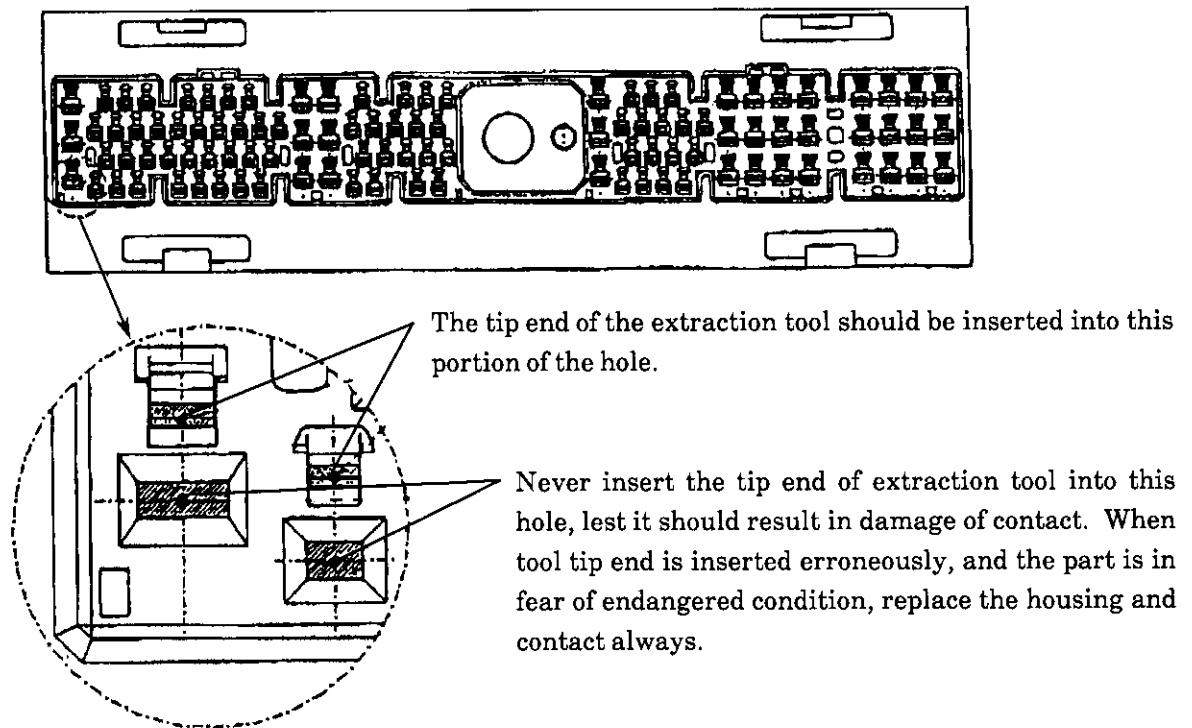
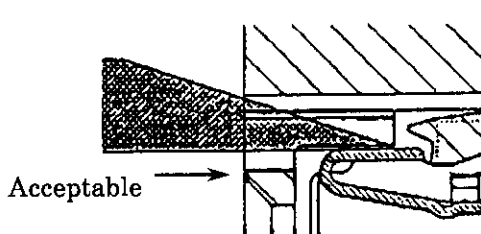
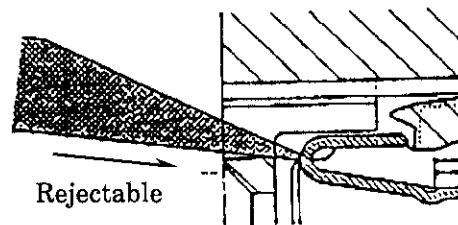

Fig. 9 Insertion of Tip End of Extraction Tool



Tip end of extraction tool is inserted horizontally.
This will disengage the contact locking rightly, without damage of contact.

Fig. 10a Correct Insertion



Tip end is inserted rather downward, being in danger of damaging the contact, as the tip end hit the contact forcefully. Contact damaging is often resulted.

Fig. 10b Incorrect Insertion

3.6 Mounting of Bolt Case onto Housing :

- (1) As shown in Fig. 11, insert bolt case into the hole of connector as far as it stops as shown in Fig. 11, then depress the stopper plate of the bolt case to bottom until it stops in the hole.

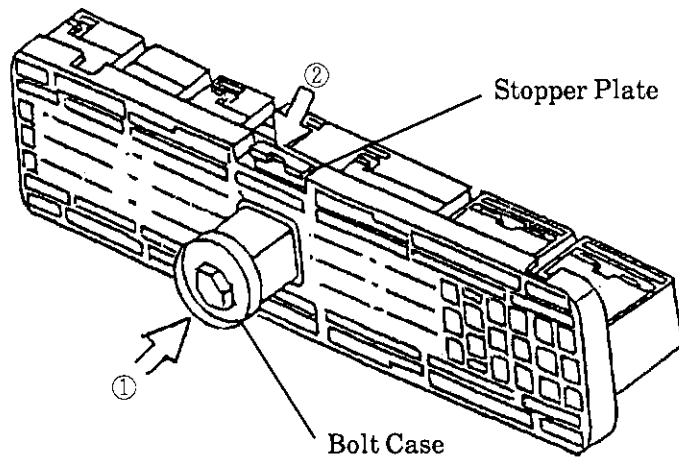

Fig. 11

- (2) When the bolt case is mounted, then, wire cover is applied next. Place the wire cover over the connector, with the eye-shot holes facing toward stopper plate of the connector. See Fig. 12.

In this case, stopper plate must be inserted into the full depth in the hole, lest it should obstacle the wire cover from entering to seat in place correctly. (For 120 Position, 104 Position and 88 Position Connectors)

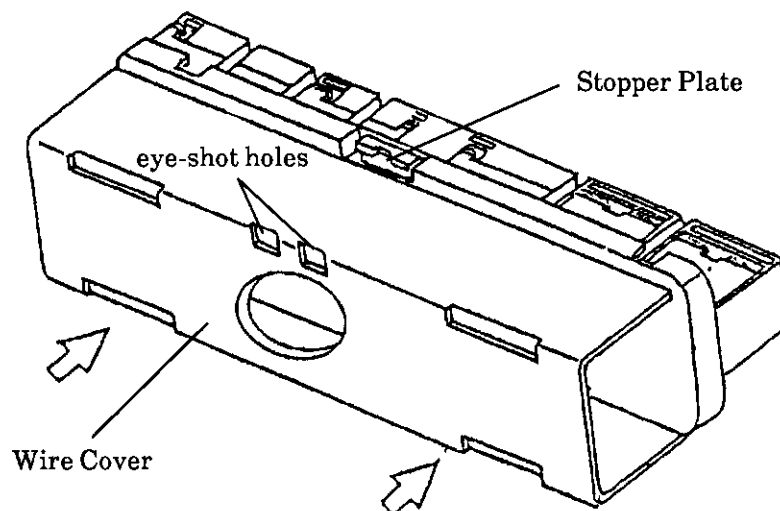
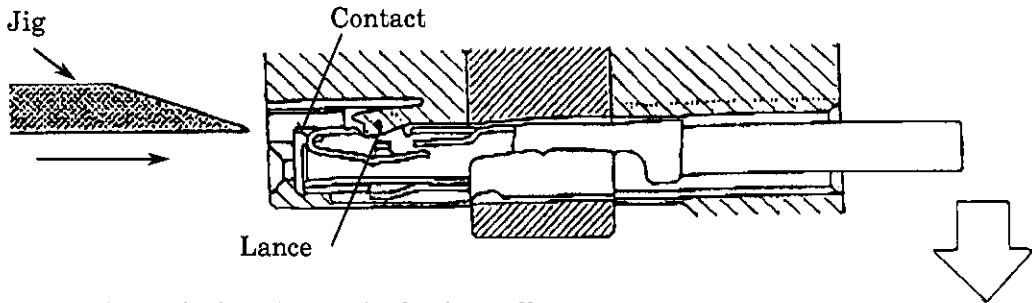

Fig. 12

For mounting wire cover onto the connectors of 76 position, 64 position and 48 position, apply wire cover to fit it on female housing, depending upon the connector feature accepts.

Contact Removal Procedure

Proceed according to the following sequence of the steps.



Insert jig tip end into the housing cavity horizontally.

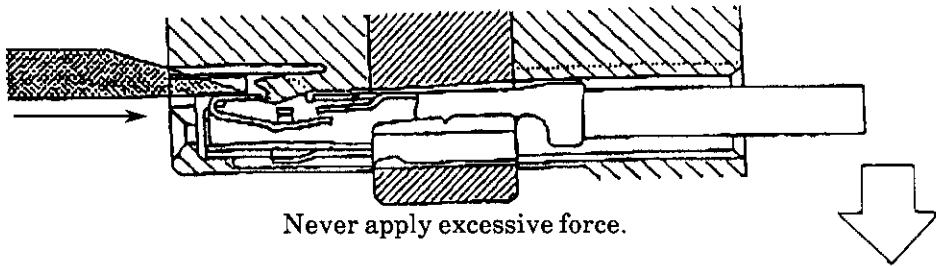

Apply tip end of the jig on the contact, and insert as far as it stops along the top of the contact.

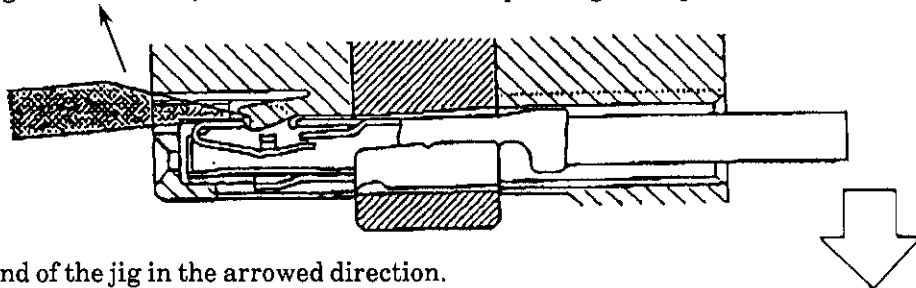

Move up the tip end of the jig in the arrowed direction.

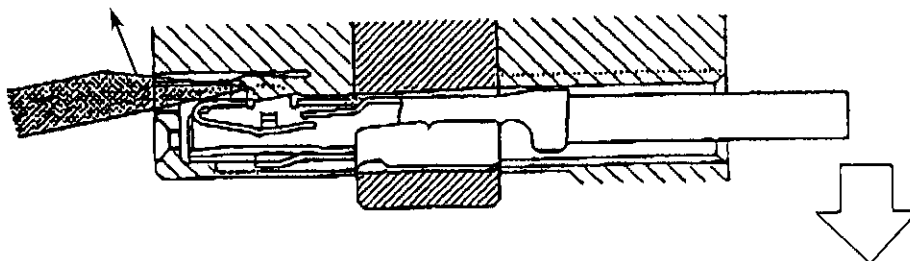

Move up the tip end of the jig until the housing lance disengages.

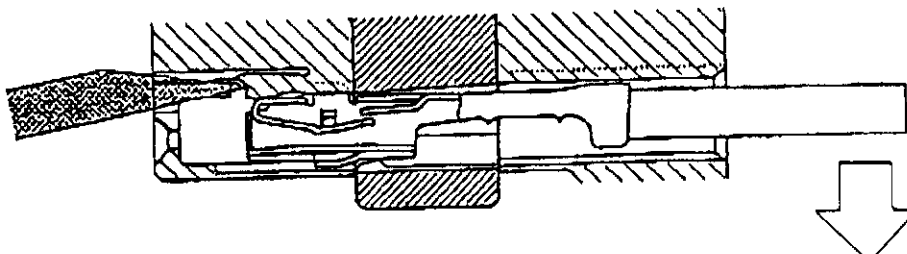

With the jig holding up the housing lance, pull the crimped wire to retract the contact in the cavity.

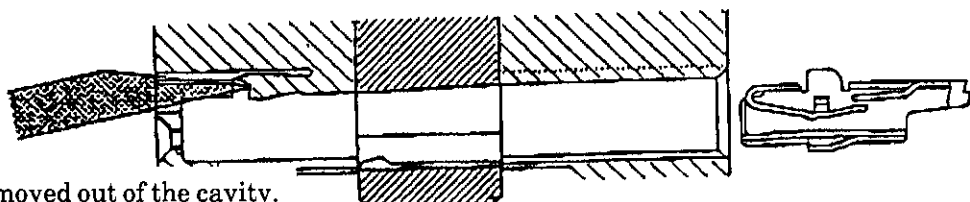

Contact is now removed out of the cavity.

Fig. 13
(8 / 9)

3.7 Replacement of Bolt Case :

- (1) Remove wire cover by applying tip end of screw driver of 6 mm in width for slotted type to the position as shown in Fig. 14 and press in the direction "P".
Upon replacement, the wire cover color may turn to milky tint. But this will be affecting no problem to practical use.

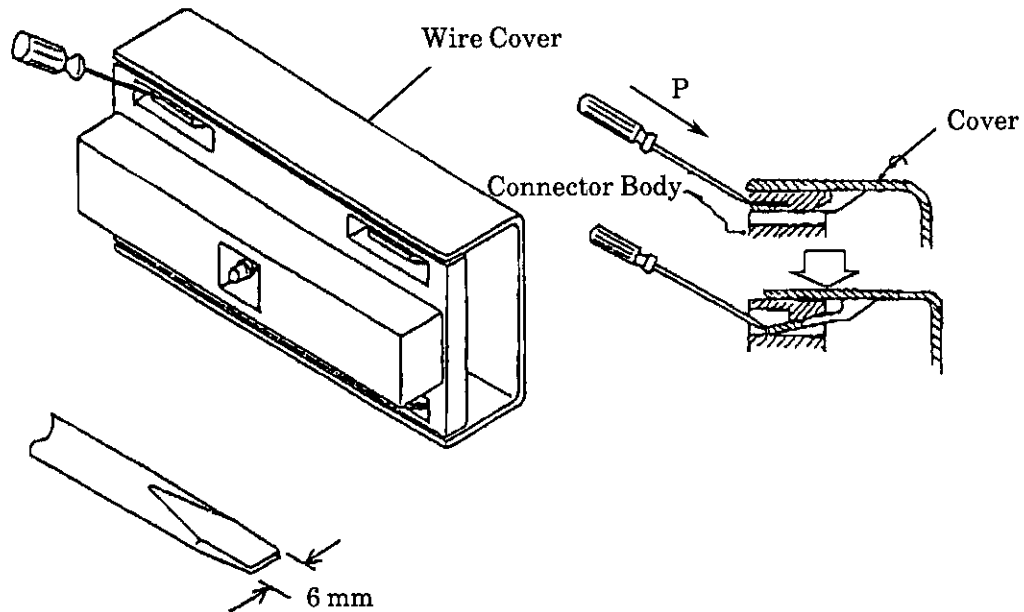

The Tip End of Slotted Type Screw Driver

Fig. 14

- (2) On the next, press up the stopper plate to the original position as shown in Fig. 15, with, the use if watchmaker's screw driver of 1.8 mm in width, and pull off the bolt case from the mounted position in the connector.

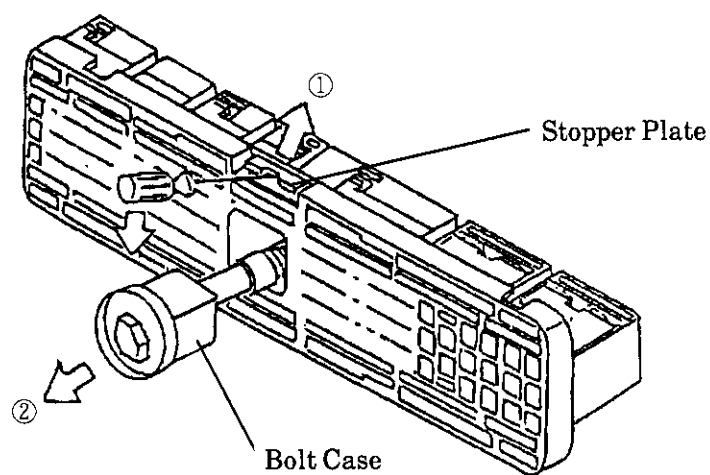

Fig. 15

作成年月日	29 May '95
改訂年月日	1/SEP/00

1. 製品型番及び名称

本製品名称は、120極、104極、88極、76極、64極、48極インパルメイトコネクタといい、Fig. 1の製品群から成っております。

製品名称				製品型番	日産部品名称	日産番号	
120極	オス	ハウジング	アセンブリ	917940-1	TK108-TAS12 HW	24347	70F60
104極	オス	ハウジング	アセンブリ	2-178079-6	TK68-TAS36 HGY	24347	70F20
88極	オス	ハウジング	アセンブリ	2-178078-6	TK58-TAS30 HW	24347	70F15
76極	オス	ハウジング	アセンブリ	174385	J07 HL	24347	51E00
64極	オス	ハウジング	アセンブリ	174836	J06 HL	24347	51E01
48極	オス	ハウジング	アセンブリ	174831	J04 HL	24347	51E02
120極	メス	ハウジング	アセンブリ	917937-1	TK108-TAS12 FW	24340	70F60
104極	メス	ハウジング	アセンブリ	178081-6	TK68-TAS36 FGY	24340	70F20
88極	メス	ハウジング	アセンブリ	178080-1	TK58-TAS30 FW	24340	70F15
76極	メス	ハウジング	アセンブリ	177700-1	TK60-TAS16 FW	24340	70F10
64極	メス	ハウジング	アセンブリ	177699-1	TK48-TAS16 FW	24340	70F05
48極	メス	ハウジング	アセンブリ	177698-1	TK40-TAS8 FW	24340	70F00
120極	ワイヤーカバー			917943-1	TK108-TAS12 COVER	24345	70F60
104極	ワイヤーカバー			178073-1	TK68TAS36 COVER	24345	70F20
88極	ワイヤーカバー			178072-1	TK58-TAS30 COVER	24345	70F15
76極	ワイヤーカバー			177697-1	TK60-TAS16 COVER	24345	70F10
64極	ワイヤーカバー			177694-1	TK48-TAS16 COVER	24345	70F05
48極	ワイヤーカバー			177688-1	TK40-TAS8 COVER	24345	70F00
ボルトケースアセンブリ				177653-2	BOLT-HLDR ASSY	24348	70F00

Fig. 1

(コンタクト)

コンタクトタイプ Contact Type		型番 Part Nos. リセプタクル Receptacle	適用電線 種類 Wire Type	適用電線 Applicable Wires					適用極数	
				0.3	0.5	0.85	1.25	2	120極 104極 88極	76極 64極 48極
040 II	S	Sn 175265-1	CAVUS	○	○	○	×	×	○	○
		Au 175266-2	CAVS/AVSS	○	○	○	×	×		
			AVS	○	○	×	×	×		
070 II	S	Sn 175268-1	CAVUS	○	○	○	×	×	○	○
		Au 175275-2	CAVS/AVSS	○	○	○	×	×		
			AVS	○	×	×	×	×		
070 II	M	Sn 175269-1	CAVUS	×	×	×	○	×	○	○
		Au 175276-2	CAVS/AVSS	×	×	○	○	×		
			AVS	×	○	○	○	×		
070 II	ML	Sn 177654-1	CAVUS	×	×	×	○	×	○	×
			CAVS/AVSS	×	×	×	○	○		
			AVS	×	×	×	×	×		

Fig. 2
(1/9)

○印:適用 ×印:適用外

2. 全体図

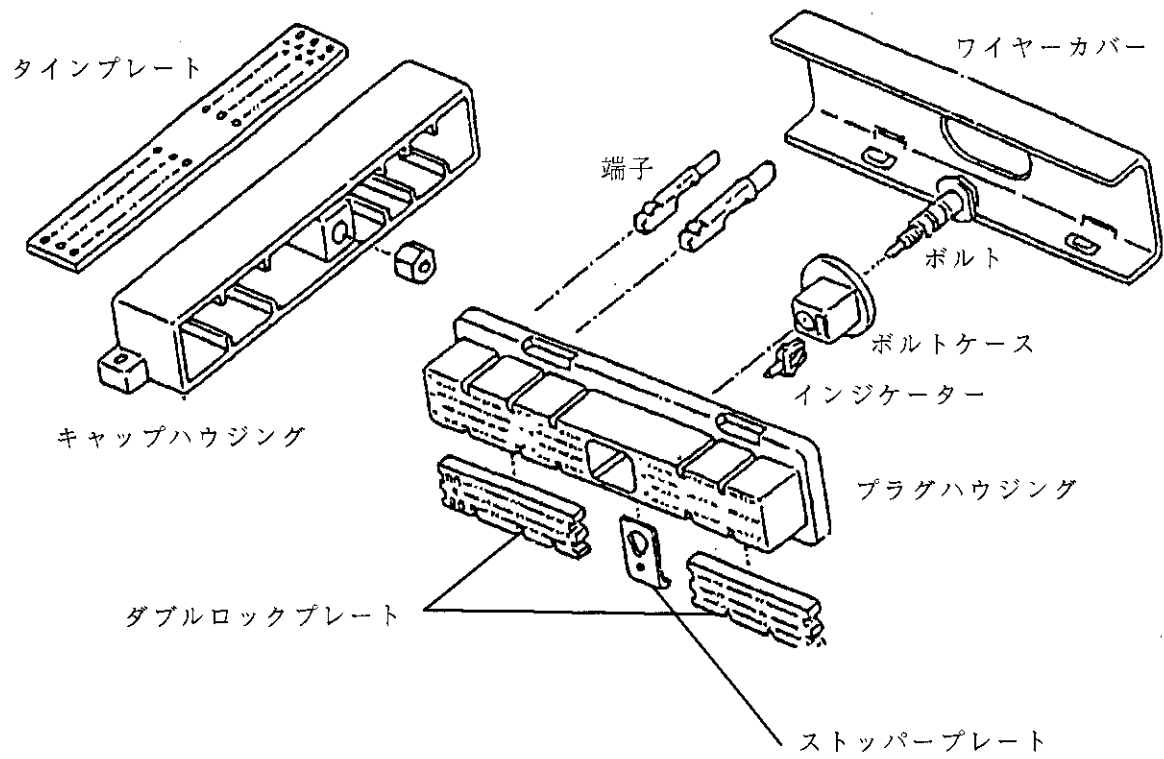

Fig. 3

1. ハーネス製造作業

3.1 コントクトの取付け方法

- (1) メスハウジングアセンブリ (108081-6, 177700-1, 177698-1, 178080-1, 177699-1)
ハウジングのリテーナ側に端子の小突起を向けます。

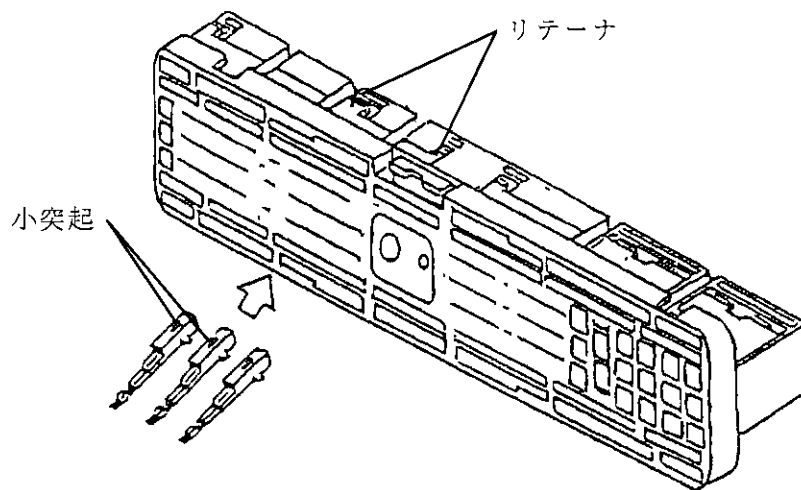

Fig. 4

3.2 挿入深さと取付けの確認

前項 3.1 の方向性を確認したうえ、端子を指定の穴にカチッという音がする迄挿入し、それ以上挿入出来ないことを確認し、さらに電線を軽く引っ張って端子が抜け出て来ないことを確認して下さい。

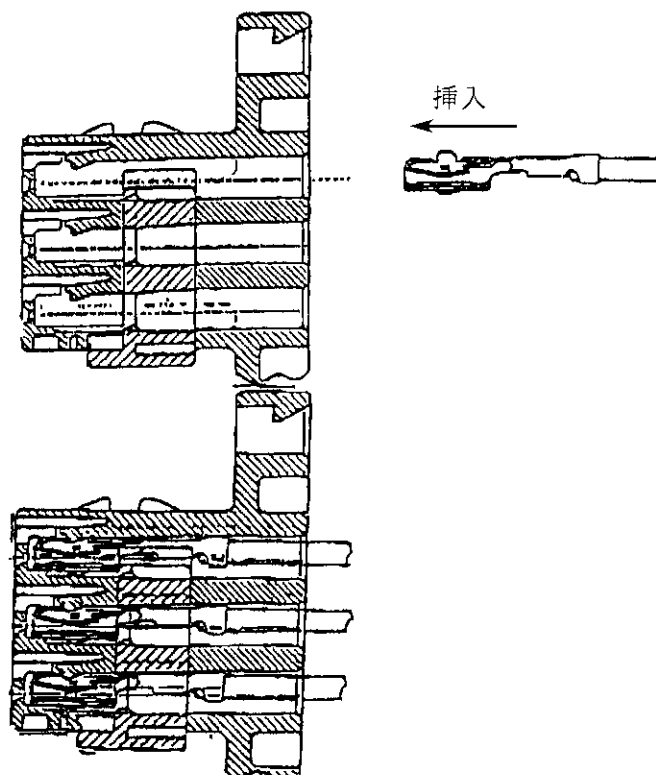
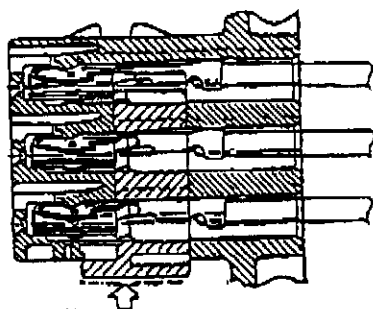

Fig. 5

3.3 リテーナの係止方法 (仮係止 → 本係止)

本コネクタのリテーナは、仮係止されております。前項 3.2 に基づき、全ての端子を挿入した後、仮係止状態のリテーナを図示の如く本係止して下さい。端子が半挿入状態であると、リテーナを本係止することは出来ません。もう一度端子の未挿入がないかどうか確認して下さい。



仮係止状態
Primarily Locked Condition

*注

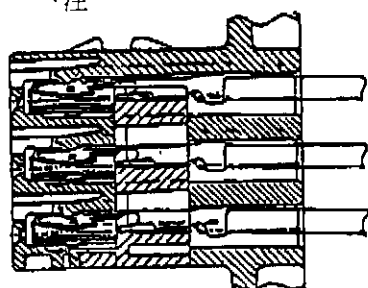

本係止状態
Secondary (Fully) Locked Condition

*注)  軽く手で押してロックして下さい。
(10 kgf 以上の力を加えると破損の恐れがあります。)

Fig. 6

3.4 リテーナの解除 (本係止 → 仮係止) (120極、104極、88極の場合)

端子の引き抜き時は、リテーナが本係止になっている場合は、仮係止状態にしてから引き抜きます。

本係止のままだと端子を抜くことが出来ません。

リテーナのドライバー挿入部に 1.2 mm の時計ドライバーを Fig. 8 の如く挿入して、本係止から仮係止状態にして下さい。もしリテーナが仮係止状態から外れてしまった場合には、元の取り付け位置に装着して仮係止状態にして下さい。

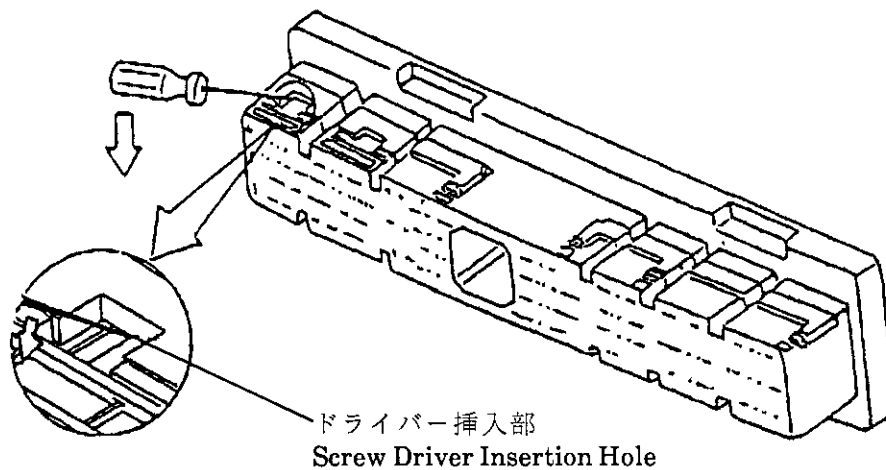
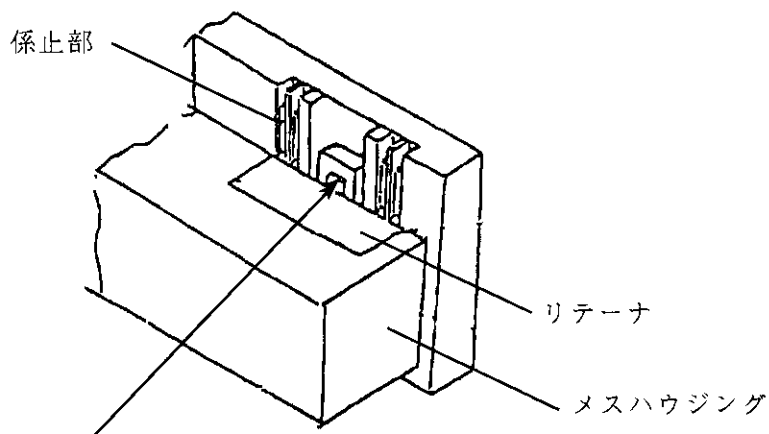

Fig. 7

リテーナの解除 (本係止 → 仮係止) (76極、64極、48極の場合)



ここへドライバーを入れて引き上げて下さい。

Fig. 8

3.5 端子引き抜き

3.5.1 引き抜き時の注意事項

一番最初にリテーナを仮係止の状態にして下さい。(3.4参照)

リテーナが本係止の状態では端子を引き抜くことは出来ません。

引抜工具を挿入する場所は Fig. 9 に従って下さい。引抜工具は必ず弊社推奨の引抜工具を使用して下さい。

引抜工具は必ず水平に穴に挿入して下さい。くれぐれも引抜工具を下向きにして Fig. 10 に示している間違ったやり方のように端子先端に当てない様に注意願います。引抜工具の AMP 型番・・・715131-1

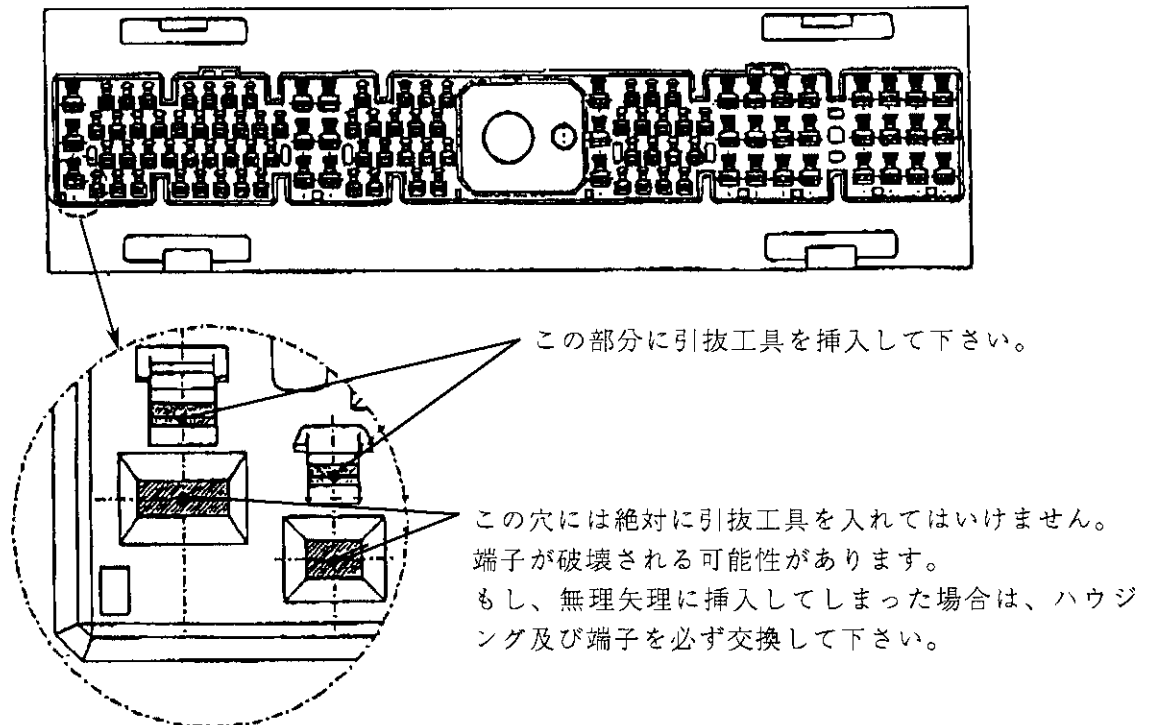
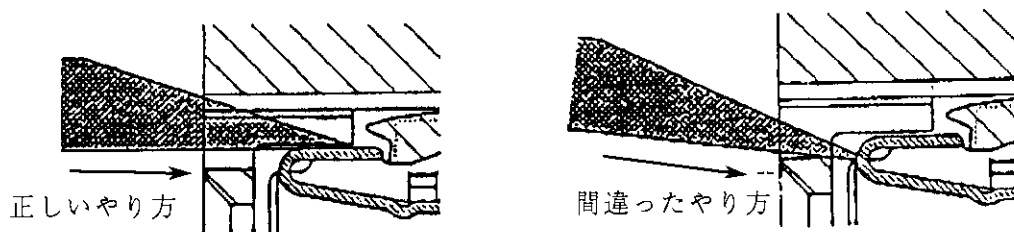

Fig. 9 引抜工具の挿入場所



引抜工具は水平にハウジングの穴に挿入して下さい。

引抜工具は絶対に端子先端に当てないようにして挿入して下さい。端子先端に引抜工具を強く押し当てますと端子が破壊される可能性があります。

Fig. 10 引抜工具の挿入

3.6 ボルトケースの装着方法

- ① ボルトケースを Fig. 11 の如く停止する位置まで挿入した後、ストッパープレートを停止する位置まで挿入して下さい。

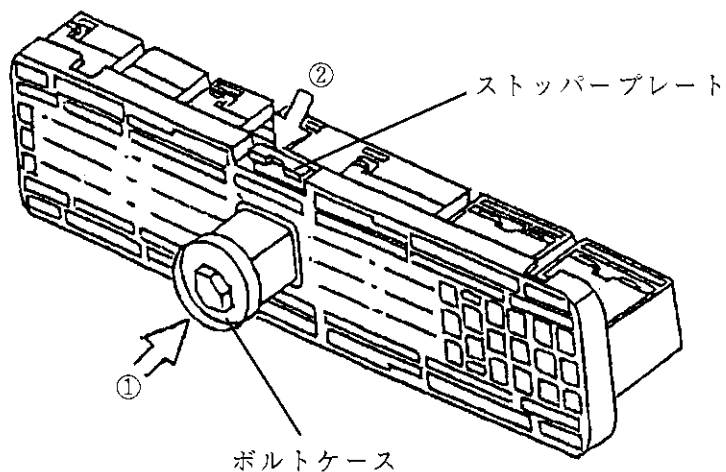

Fig. 11

- ② ワイヤカバーの目印穴を Fig. 12 の如くストッパープレート側に向けて装着して下さい。この時ストッパープレートが完全に挿入されていないと、ワイヤカバーを装着することは出来ません。(120 極、104 極、88 極)

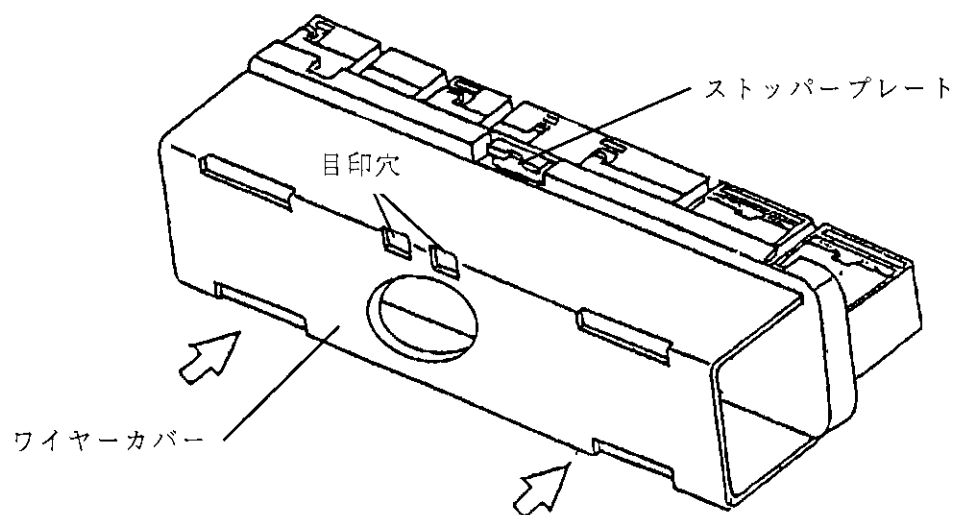

Fig. 12

76 極、64 極、48 極は、メスハウジングの形状に合わせてワイヤカバーを装着して下さい。

端子引き抜き方法は下記のフローに従って作業を行ってください。

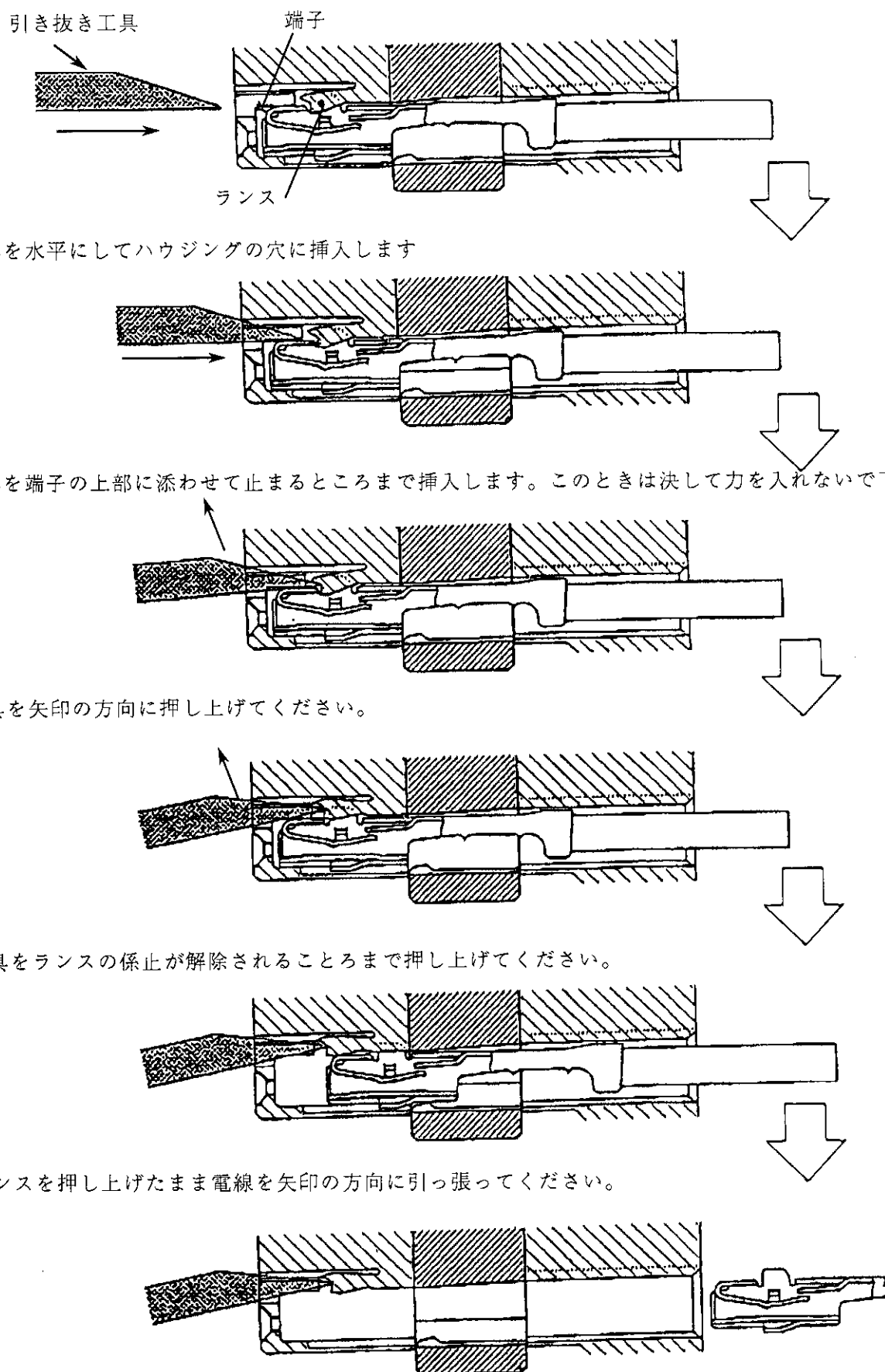

Fig. 13

3.7 ボルトケースの取り外し方法

- ① Fig. 14 の如く幅 6 mm マイナスドライバーを P 方向に押し、ワイヤーカバーを取り外して下さい。
取り外し時、若干白化することがありますが実使用上問題ありません。

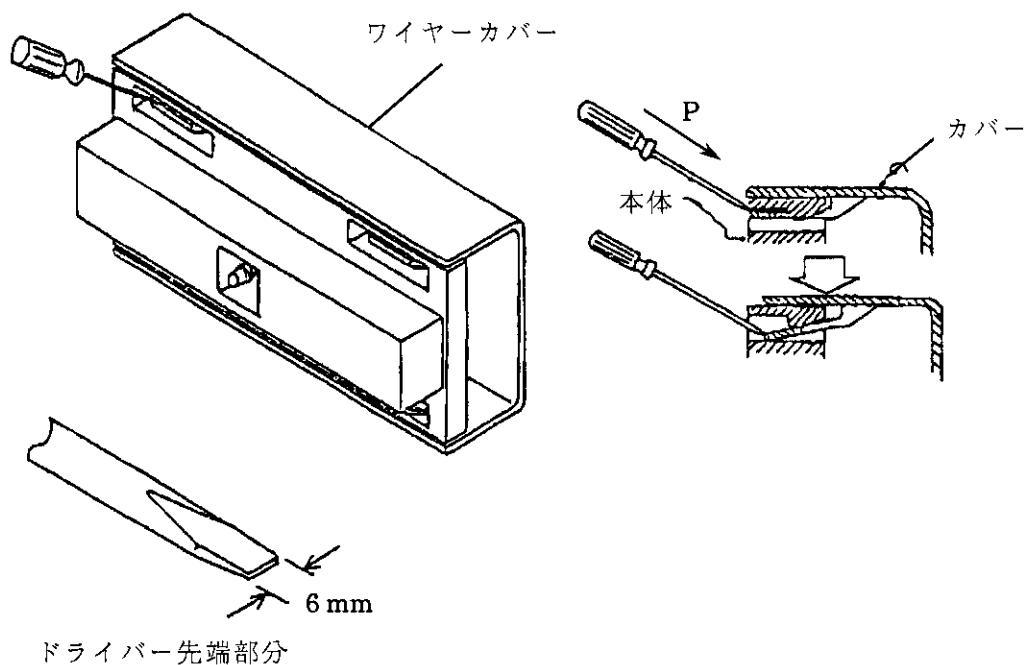

Fig. 14

- ② 次に Fig. 15 の如くストッパープレートを時計ドライバー 1.8 mm で所定の位置にまで押し上げてからボルトケースを引き抜いて下さい。

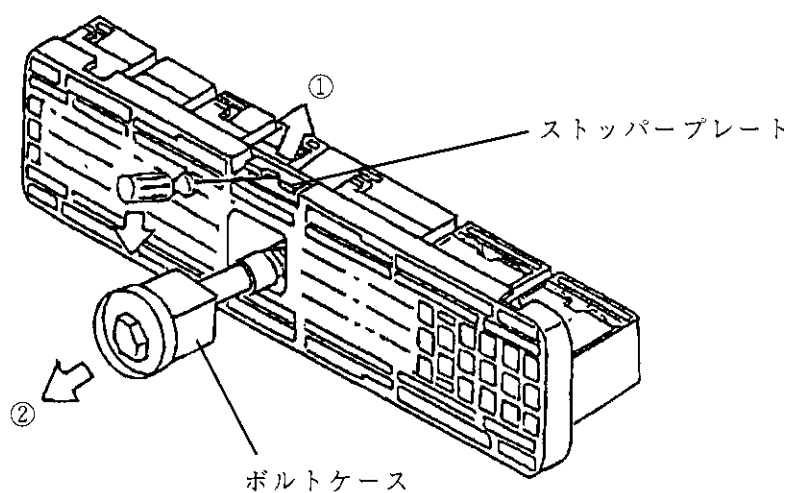

Fig. 15