

DESCRIPTION: MALE // D-SUB CRIMP CONTACT // LOOSE

SPECIFICATIONS:

MATERIALS:

CONTACT:

BRASS

PLATING:

SEE P/N TABLE BELOW

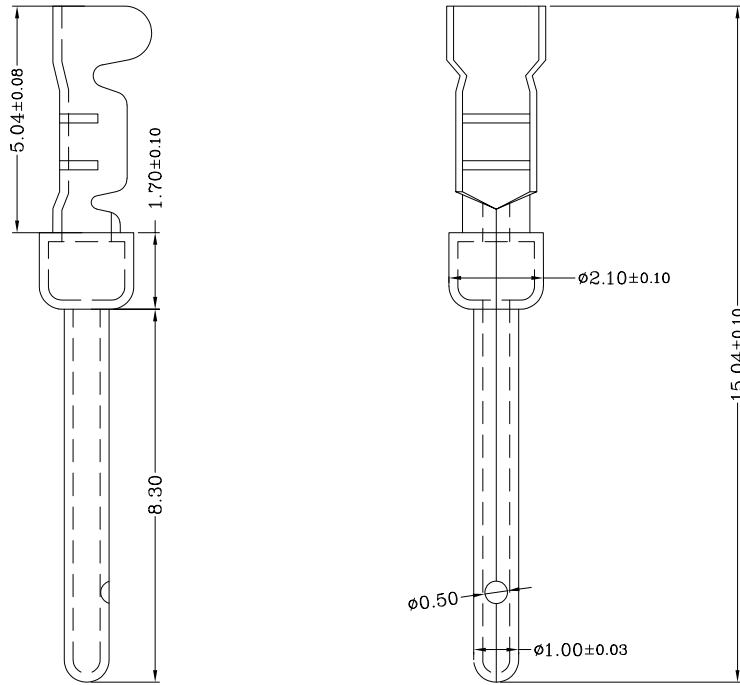

PART NUMBER	PLATING	WIRE AWG RANGE
170-101-170L001	GOLD FLASH ON MATING AREA // NICKEL ON WIRE CRIMP AREA	20-28 AWG
170-101-170L002	10µ" GOLD OVER 50µ" NICKEL ENTIRE CONTACT	20-28 AWG
170-101-170L003	30µ" GOLD OVER 100µ" NICKEL ENTIRE CONTACT	20-28 AWG

NOTE: CONTACTS SUPPLIED IN BAGS OF 500/pcs

NORCOMP CRIMP TOOL PART NUMBER => 170-701-170-000

RoHS COMPLIANT

UNITS = mm

DO NOT SCALE FROM DRAWING



THESE DRAWINGS AND SPECIFICATIONS ARE THE PROPERTY OF NorComp AND SHALL NOT BE REPRODUCED, COPIED OR USED AS THE BASIS FOR THE MANUFACTURE OR SALE OF APPARATUS WITHOUT WRITTEN PERMISSION.

DRAWN:
P. JENKINS
DATE:
05/23/2002

NorComp

SCALE: NTS	SHEET 1	OF 1	REV 4
DWG NO.		170-101-170L00Y	