

MAX33070E/MAX33071E/MAX33074E

+3.3V and +5.0V, RS-485 Half Duplex Transceiver with $\pm 65\text{V}$ Fault Protection, $\pm 40\text{V}$ CMR, and $\pm 40\text{kV}$ ESD

General Description

The MAX33070E/MAX33071E/MAX33074E are a family of fault-protected RS-485/RS-422 transceivers with high $\pm 65\text{V}$ protection for overvoltage conditions on the communication bus lines, ensuring robust protection in harsh industrial environments. All devices have $\pm 40\text{V}$ of common-mode range (CMR) within V_{CCH} (+4.5V to +5.5V), exceeding the RS-485 standard of -7V to +12V, making them suitable for electrically noisy environments where different systems have shifting ground levels relative to each other. They also incorporate a high ESD protection circuit capable of protecting against $\pm 40\text{kV}$ of ESD Human Body Model (HBM) for driver outputs and receiver inputs (A and B data lines). Each device contains one driver and one receiver and operates over the +3V to +5.5V supply range, making it convenient for designers to use one part with either +3.3V or +5V supply voltages across multiple end equipment.

These devices feature a receiver enable ($\overline{\text{RE}}$) input that allows for a low-current shutdown state. The MAX33070E features slew-rate-limited outputs for data rates up to 500kbps. For applications requiring higher bandwidth, the MAX33071E is rated up to 2Mbps, and the MAX33074E up to 20Mbps. These transceivers are optimized for robust communication in noisy environments. A true fail-safe feature guarantees a logic-high on the receiver output when the inputs are open or shorted. Driver outputs are protected against short-circuit conditions. The receivers feature a 1/8-unit load input impedance, allowing up to 256 transceivers on a bus.

The MAX33070E/MAX33071E are available in an 8-pin SO, and the MAX33074E is available in an 8-pin SO with an exposed pad. All three devices operate over the -40°C to $+125^{\circ}\text{C}$ temperature range.

Applications

- Industrial Automation Equipment
- Home and Building Automation
- Agriculture and Heavy Machinery
- Power Supply and UPS
- Elevator Control
- Motion Controllers

Benefits and Features

- Integrated Protection for Robust Communication
 - Protection on Driver Outputs/Receiver Inputs (A, B Data Lines)
 - $\pm 65\text{V}$ Fault Protection Range on Driver Outputs/Receiver Inputs
 - $\pm 40\text{V}$ Common-Mode Range on Driver Outputs/Receiver Inputs
 - $\pm 40\text{kV}$ Human Body Model (JEDEC JS-001-2017) ESD Protection
 - $\pm 15\text{kV}$ Air-Gap Discharge (IEC 61000-4-2) ESD Protection
 - $\pm 10\text{kV}$ Contact Discharge (IEC 61000-4-2) ESD Protection
 - Hot-Swap Protection
 - Short-Circuit Protection
 - Thermal Shutdown
 - True Fail-Safe Guarantees Known Receiver Output State
 - Wide Operating Temperature Range from -40°C to $+125^{\circ}\text{C}$
- High-Performance Transceiver Enables Flexible Designs
 - Compliant with RS-485 EIA/TIA-485 Standard
 - 500kbps (MAX33070E), 2Mbps (MAX33071E), 20Mbps (MAX33074E) Maximum Data Rate
 - 3.3V and 5.0V Supply Voltage
 - 1/8 Unit Load for up to 256 Devices on the Bus

Ordering Information appears at end of data sheet.

Simplified Block Diagram

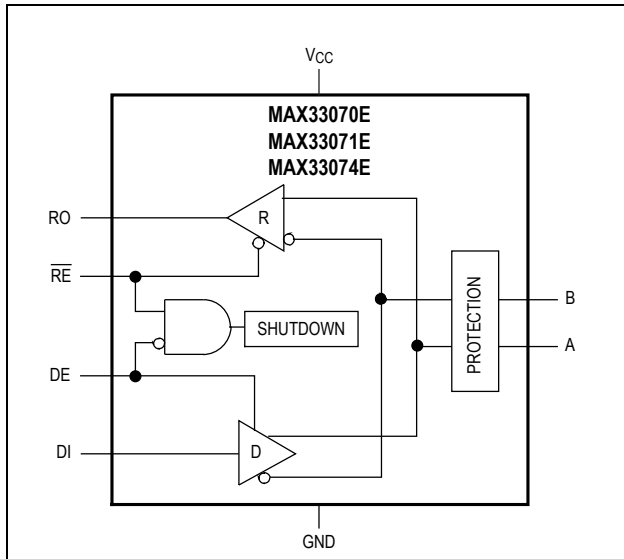

Absolute Maximum Ratings

V_{CC}	-0.3V to +6V
RO	-0.3V to $V_{CC} + 0.3V$
DE, DI, \overline{RE}	-0.3V to +6V
A, B (Continuous)	-70V to +70V
Short-Circuit Duration (RO, A, B)	Continuous
Continuous Power Dissipation	
8-Pin SO +70°C (derate 7.6mW/°C above +70°C)	606.1mW

8-Pin SO-EP +70°C (derate 24.4mW/°C above +70°C)	1951.2mW
Operating Temperature Range	-40°C to +125°C
Junction Temperature	+150°C
Storage Temperature Range	-65°C to +150°C
Lead Temperature (soldering, 10s)	+300°C
Soldering Temperature (reflow)	+260°C

Stresses beyond those listed under "Absolute Maximum Ratings" may cause permanent damage to the device. These are stress ratings only, and functional operation of the device at these or any other conditions beyond those indicated in the operational sections of the specifications is not implied. Exposure to absolute maximum rating conditions for extended periods may affect device reliability.

+3.3V and +5.0V, RS-485 Half Duplex Transceiver with $\pm 65\text{V}$ Fault Protection, $\pm 40\text{V}$ CMR, and $\pm 40\text{kV}$ ESD

MAX33070E/MAX33071E/MAX33074E

Package Information

SO

Package Code	S8+4
Outline Number	21-0041
Land Pattern Number	90-0096
THERMAL RESISTANCE, FOUR-LAYER BOARD	
Junction to Ambient (θ_{JA})	132°C/W
Junction to Case (θ_{JC})	38°C/W

SO-EP

Package Code	S8E+14C
Outline Number	21-0111
Land Pattern Number	90-0151
THERMAL RESISTANCE, FOUR-LAYER BOARD	
Junction to Ambient (θ_{JA})	41°C/W
Junction to Case (θ_{JC})	7°C/W

For the latest package outline information and land patterns (footprints), go to www.maximintegrated.com/packages. Note that a "+", "#", or "-" in the package code indicates RoHS status only. Package drawings may show a different suffix character, but the drawing pertains to the package regardless of RoHS status.

Package thermal resistances were obtained using the method described in JEDEC specification JESD51-7, using a four-layer board. For detailed information on package thermal considerations, refer to www.maximintegrated.com/thermal-tutorial.

**+3.3V and +5.0V, RS-485 Half Duplex
Transceiver with ±65V Fault Protection,
±40V CMR, and ±40kV ESD**

MAX33070E/MAX33071E/MAX33074E

Electrical Characteristics

($V_{CC} = 3.0V$ to $3.6V$ and $V_{CC} = 4.5V$ to $5.5V$, $T_A = T_{MIN}$ to T_{MAX} , unless otherwise noted. Typical values are at $V_{CC} = 5.0V$ and $T_A = +25^{\circ}C$. (j))

PARAMETER	SYMBOL	CONDITIONS	MIN	TYP	MAX	UNITS	GL	
POWER								
Supply Voltage	V_{CCL}	Low range	3		3.6	V	II	
	V_{CCH}	High range	4.5		5.5		II	
Supply Current	I_{CC}	DE = high, \overline{RE} = low, no load, no switching		6		mA	II	
Shutdown Supply Current	I_{SHDN}	DE = 0V, $\overline{RE} = V_{CC}$		4		μA	II	
DRIVER								
Differential Driver Output	$ V_{OD} $	Figure 1a, $R_L = 54\Omega$	1.5			V	II	
		Figure 1a, $R_L = 100\Omega$	2.0				V	
		Figure 1b	1.5				II	
External Common-Mode Voltage	V_{CM}	Figure 1b, $V_{CC} = V_{CCL}$	-25		+25	V	II	
		Figure 1b, $V_{CC} = V_{CCH}$	-40		+40		II	
Change in Magnitude of Differential Driver Output Voltage	ΔV_{OD}	$R_L = 54\Omega$ or 100Ω , Figure 1a (Note 2)	-0.2		+0.2	V	II	
Driver Common-Mode Output Voltage	V_{OC}	$R_L = 54\Omega$ or 100Ω , Figure 1a	1	$V_{CC}/2$	3	V	II	
Change in Magnitude of Common-Mode Voltage	ΔV_{OC}	$R_L = 54\Omega$ or 100Ω , Figure 1a (Note 2)	-0.1		+0.1	V	II	
Single-Ended Driver Output Voltage High	V_{OH}	A or B output, output is high, $I_{SOURCE} = 3mA$	2.4	$V_{CC} - 0.2$		V	II	
Single-Ended Driver Output Voltage Low	V_{OL}	A or B output, output is low, $I_{SINK} = 3mA$			0.2	V	II	
Driver Short-Circuit Output Current	I_{SC_DR}	$-65V \leq (V_A \text{ or } V_B) < 0V$ or $V_{CC} < (V_A \text{ or } V_B) \leq +65V$ (Note 3 , Note 5)			450	mA	V	
Average Driver Short-Circuit Output Current	I_{AVG_SCDR}	$0V \leq (V_A \text{ or } V_B) \leq V_{CC}$			450	mA	II	
RECEIVER								
Input Current (A, B)	I_A, I_B	DE = low, $0V \leq V_{CC} \leq 5.5V$	$V_{CM} = +40V$			410	μA	II
			$V_{CM} = -40V$	-424				II
Receiver Input Resistance	R_{IN}	Over V_{CM} range	96			k Ω	II	
Common-Mode Voltage Range	V_{CM}	$V_{CC} = V_{CCL}$	-25		+25	V	II	
		$V_{CC} = V_{CCH}$	-40		+40		II	

+3.3V and +5.0V, RS-485 Half Duplex Transceiver with $\pm 65V$ Fault Protection, $\pm 40V$ CMR, and $\pm 40kV$ ESD

MAX33070E/MAX33071E/MAX33074E

($V_{CC} = 3.0V$ to $3.6V$ and $V_{CC} = 4.5V$ to $5.5V$, $T_A = T_{MIN}$ to T_{MAX} , unless otherwise noted. Typical values are at $V_{CC} = 5.0V$ and $T_A = +25^\circ C$. ())

PARAMETER	SYMBOL	CONDITIONS	MIN	TYP	MAX	UNITS	GL
Receiver Differential Threshold Voltage Rising	V_{TLH}	Over V_{CM} range			-40	mV	II
Receiver Differential Threshold Voltage Falling	V_{THL}	Over V_{CM} range	-200			mV	II
Receiver Input Hysteresis	ΔV_{TH}			100		mV	V
Differential Input Capacitance	$C_{A,B}$	Measured between A and B, $f = 1MHz$		50		pF	V
LOGIC OUTPUT							
RO Output Logic-High Voltage	V_{OH}	$I_{SOURCE} = 3mA$, $(V_A - V_B) \geq -50mV$	$V_{CC} - 0.4$			V	II
RO Output Logic-Low Voltage	V_{OL}	$I_{SINK} = 3mA$, $(V_A - V_B) \leq -200mV$			0.4	V	II
RO Leakage Current	I_{OZR}	$\overline{RE} = V_{IH}$, $0V \leq V_{RO} \leq V_{CC}$	-1		+1	μA	II
RO Short-Circuit Current	I_{IOSR}	$0 \leq (V_A - V_B) \leq V_{CC}$	$V_{CC} = V_{CCL}$		90	mA	II
			$V_{CC} = V_{CCH}$		190		II
LOGIC INPUTS (DE, DI, RE)							
Input Logic-High Voltage	V_{IH}		2			V	IV
Input Logic-Low Voltage	V_{IL}				0.8	V	IV
Input Hysteresis	V_{HYS}			100		mV	VI
Input Leakage Current	I_{IN}	After first transition of DE and \overline{RE}	-1		+1	μA	II
Input Impedance on First Transition	R_{IN_FT}	DE	1		10	k Ω	II
PROTECTION							
Thermal Shutdown Threshold	T_{SHDN}	Temperature rising		+160		$^\circ C$	V
Thermal Shutdown Hysteresis	T_{HYST}			12		$^\circ C$	V
ESD Protection (A, B Pins to GND)		Human Body Model (JEDEC JS-001-2017)		± 40		kV	III
		IEC 61000-4-2 Contact Discharge		± 10			III
		IEC 61000-4-2 Air Gap		± 15			III
ESD Protection (All Other Pins)		Human Body Model		± 4000		V	III
		Charge Device Model		± 2000			III
		A, B independently or simultaneously	-65		+65	V	V

+3.3V and +5.0V, RS-485 Half Duplex Transceiver with ±65V Fault Protection, ±40V CMR, and ±40kV ESD

MAX33070E/MAX33071E/MAX33074E

($V_{CC} = 3.0V$ to $3.6V$ and $V_{CC} = 4.5V$ to $5.5V$, $T_A = T_{MIN}$ to T_{MAX} , unless otherwise noted. Typical values are at $V_{CC} = 5.0V$ and $T_A = +25^{\circ}C$. ())

PARAMETER	SYMBOL	CONDITIONS	MIN	TYP	MAX	UNITS	GL	
Fault Protection Range (A, B Pins to GND)		A and B opposite polarity from separate supplies simultaneously (Note 5 , not production tested)	-65		+65		V	
SWITCHING								
DRIVER (Note 4) (Note 5)								
Driver Propagation Delay	t_{DPLH}, t_{DPHL}	$R_L = 54\Omega, C_L = 50pF$ (Figure 2) (Figure 3)	MAX33070E		50	1000	ns	II
			MAX33071E/74E		25	50		II
Differential Driver Output Skew $ t_{DPLH} - t_{DPHL} $	t_{DSKEW}	$R_L = 54\Omega, C_L = 50pF$ (Figure 2) (Figure 3)	MAX33070E		10	140	ns	V
			MAX33071E/74E		2	10		V
Driver Differential Output Rise or Fall Time	t_{LH}, t_{HL}	$R_L = 54\Omega, C_L = 50pF$ (Figure 2) (Figure 3)	MAX33070E		30	600	ns	II
			MAX33071E/74E		8	15		II
Maximum Data Rate	DR_{MAX}	$R_L = 54\Omega, C_L = 50pF$	MAX33070E	0.5			Mbps	V
			MAX33071E	2				V
			MAX33074E	20				V
Driver Enable to Output High or Output Low	t_{DZH}, t_{DZL}	$R_L = 110\Omega, C_L = 50pF$ (Figure 4) (Figure 5)	MAX33070E		500		ns	V
			MAX33071E/74E		400			V
Driver Enable Time	t_D	$-40V \leq V_{CM} \leq +40V$, Figure 1b	MAX33070E		3.5		μs	V
			MAX33071E/74E		1			V
Driver Disable Time from Output Low or Output High	t_{DLZ}, t_{DHZ}	$R_L = 110\Omega, C_L = 50pF$ (Figure 4) (Figure 5)			500		ns	V
Driver Enable Time from Shutdown to Output High	t_{DZH_SHDN}	$R_L = 110\Omega, C_L = 50pF$ (Figure 4) (Figure 6)			170		μs	II
Driver Enable Time from Shutdown to Output Low	t_{DZL_SHDN}	$R_L = 110\Omega, C_L = 50pF$ (Figure 4) (Figure 6)			170		μs	II
Time to Shutdown	t_{SHDN}	(Note 6)	50	800			ns	II
RECEIVER (Note 4) (Note 5)								
Receiver Propagation Delay	t_{RPLH}, t_{RPHL}	$C_L = 15pF$ (Figure 6) (Figure 7)	MAX33070E		130	200	ns	II
			MAX33071E/74E		55	75		II
Receiver Output Skew	t_{RSKEW}	$C_L = 15pF$ (Figure 6) (Figure 7)	MAX33070E		2	30	ns	IV
			MAX33071E/74E		1	10		IV

**+3.3V and +5.0V, RS-485 Half Duplex
Transceiver with ±65V Fault Protection,
±40V CMR, and ±40kV ESD**

MAX33070E/MAX33071E/MAX33074E

($V_{CC} = 3.0V$ to $3.6V$ and $V_{CC} = 4.5V$ to $5.5V$, $T_A = T_{MIN}$ to T_{MAX} , unless otherwise noted. Typical values are at $V_{CC} = 5.0V$ and $T_A = +25^{\circ}C$. ())

PARAMETER	SYMBOL	CONDITIONS	MIN	TYP	MAX	UNITS	GL
Receiver Enable to Output High	t_{RZH}	$R_L = 1k\Omega$, $C_L = 15pF$, $DE = V_{IH}$ (Figure 8)		400		ns	II
Receiver Enable to Output Low	t_{RZL}	$R_L = 1k\Omega$, $C_L = 15pF$, $DE = V_{IH}$ (Figure 8)		400		ns	II
Receiver Disable Time from Low	t_{RLZ}	$R_L = 1k\Omega$, $C_L = 15pF$, $DE = V_{IH}$ (Figure 8)		400		ns	V
Receiver Disable Time from High	t_{RHZ}	$R_L = 1k\Omega$, $C_L = 15pF$, $DE = V_{IH}$ (Figure 8)		400		ns	V
Receiver Enable from Shutdown to Output High	t_{RLZ_SHDN}	$R_L = 1k\Omega$, $C_L = 15pF$ (Figure 8)			170	μs	II
Receiver Enable from Shutdown to Output Low	t_{RHZ_SHDN}	$R_L = 1k\Omega$, $C_L = 15pF$ (Figure 8)			170	μs	II
Time to Shutdown	t_{DSDN}	(Note 6)	50		800	ns	II

GUARANTEE LEVEL	DESCRIPTION
I	Production Tested @ Multiple Temps
II	Production Tested @ Room Temp, Characterized @ Multiple Temps
IIsc	Production Tested via Scan @ Room Temp, Characterized via Scan @ Multiple Temps
III	Sample Tested
IV	Not Production Tested, Characterized by ATE
V	Not Production Tested, Characterized by Bench (GBDC)
VI	Internal Design Target
VII	Production Tested, Internal Only
VIII	Production Tested @ Hot, Characterized @ Multiple Temps

Note 1: All devices are 100% production tested at $T_A = +25^{\circ}C$. Specifications over temperature are guaranteed by design.

Note 2: ΔV_{OD} and ΔV_{OC} are the changes in V_{OD} and V_{OC} , respectively, when DI changes state.

Note 3: The short-circuit current is 450mA (max) for a short period (30 μs , typ). If the short circuit persists, the outputs are then set to high impedance for 300ms (typ).

Note 4: Capacitive load includes test probe and fixture capacitance.

Note 5: Guaranteed by design. Not production tested.

Note 6: Shutdown is enabled when \overline{RE} is high and DE is low. If the enable inputs are in this state for less than 50ns, the device is guaranteed not to enter shutdown. If the enable inputs are held in this state for at least 800ns, the device is guaranteed to have entered shutdown.

Timing Diagrams

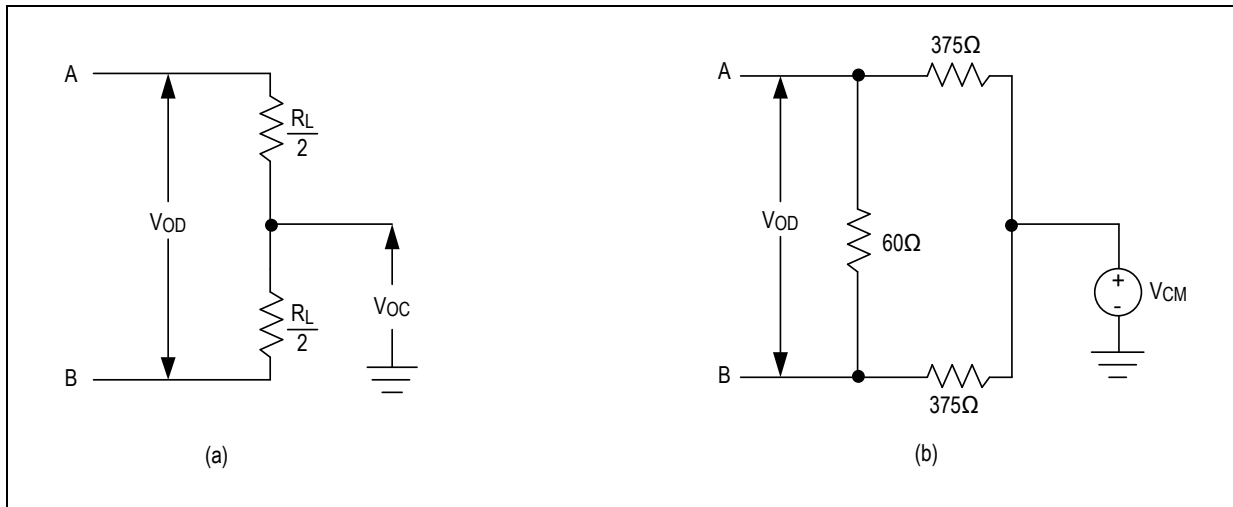

Figure 1. Driver DC Test Load

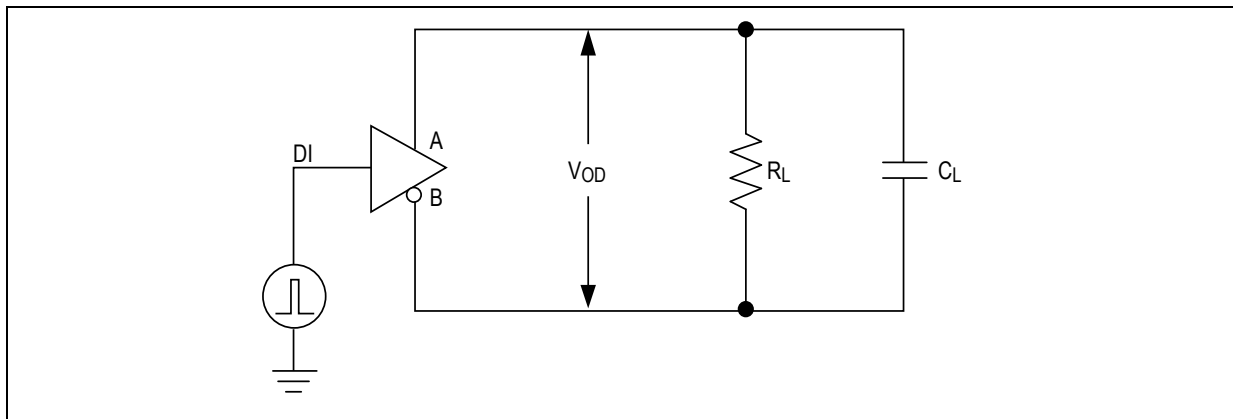

Figure 2. Driver Timer Test Circuit

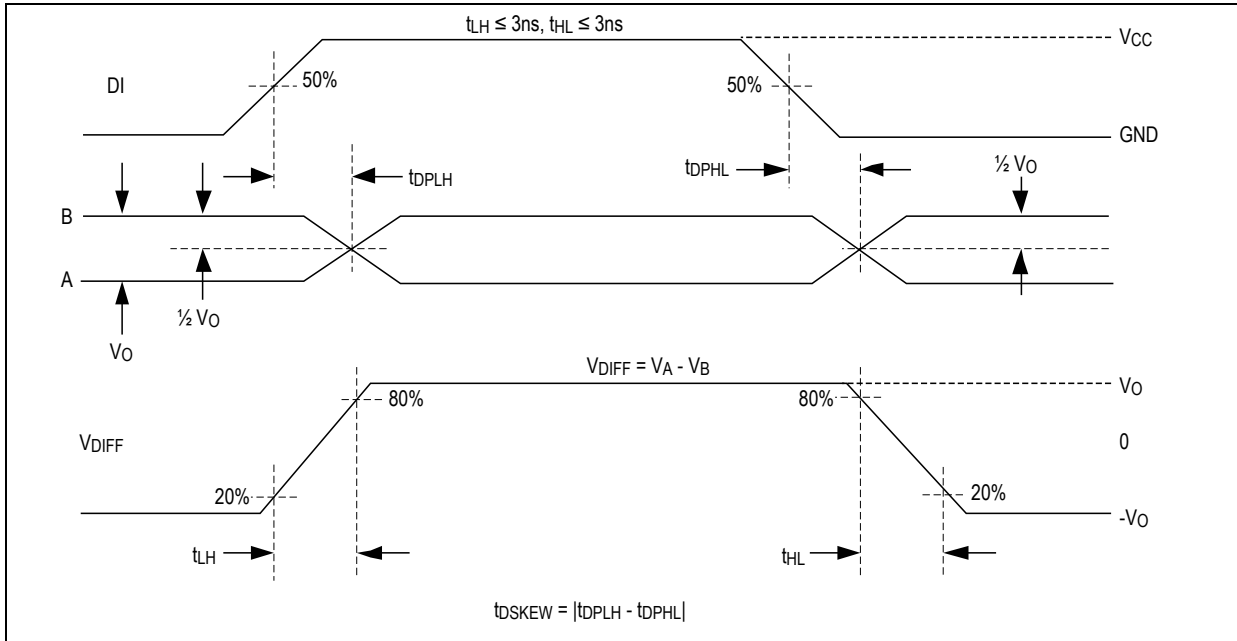

Figure 3. Driver Propagation Delays

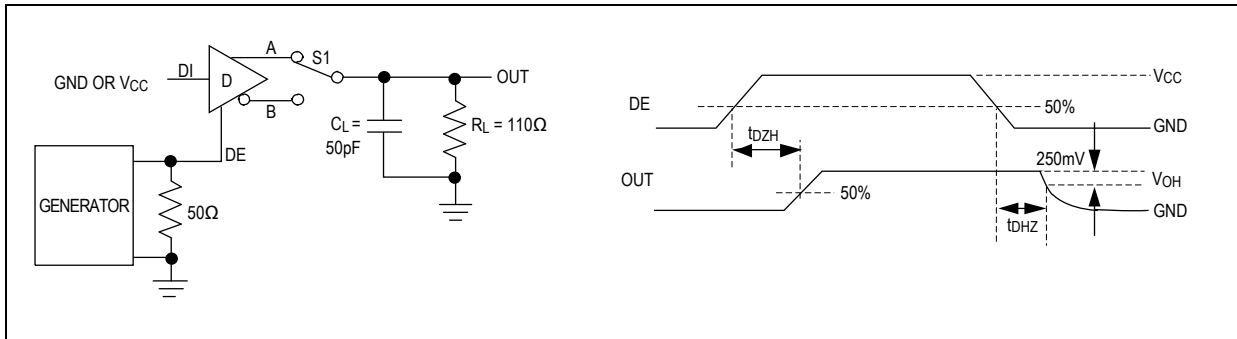

Figure 4. Driver Enable and Disable Times (t_{DZH} , t_{DHZ})

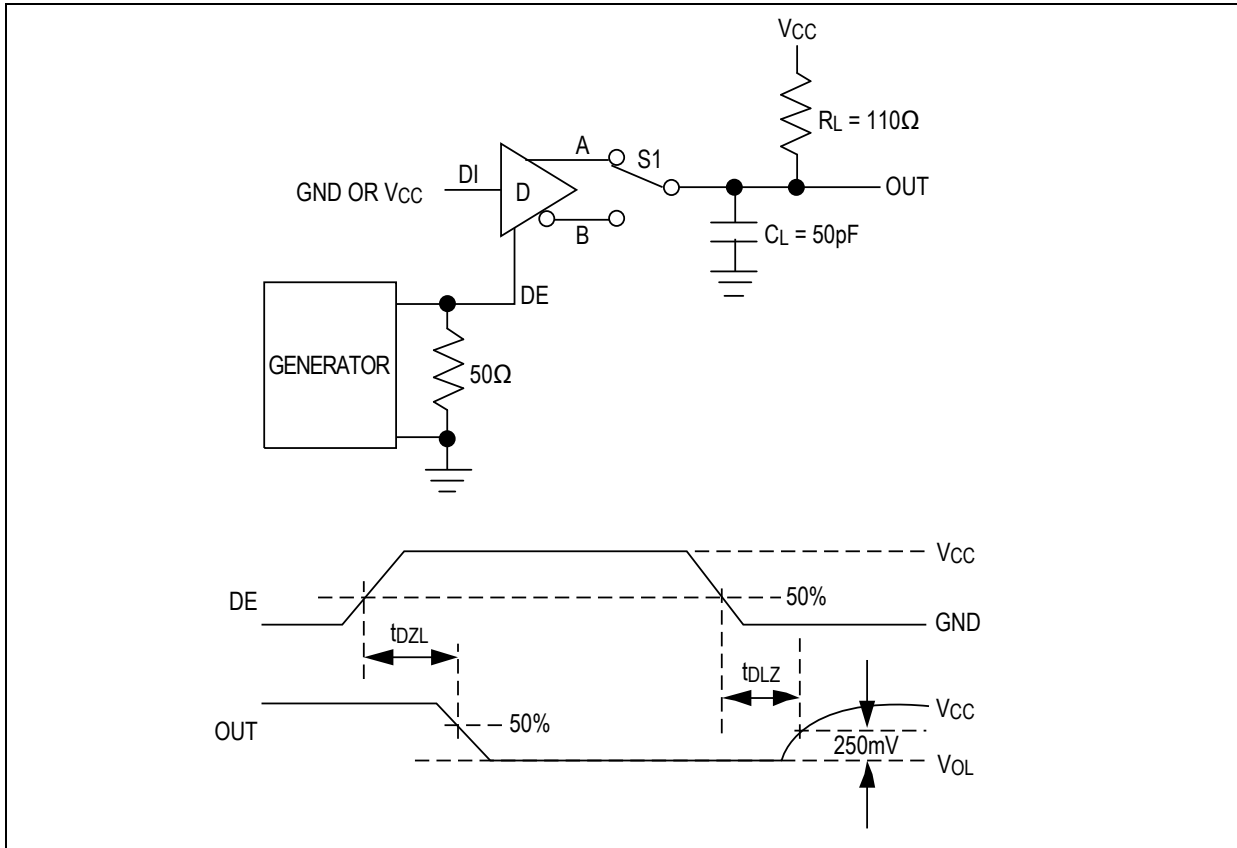

Figure 5. Driver Enable and Disable Times (t_{DZL} , t_{DLZ})

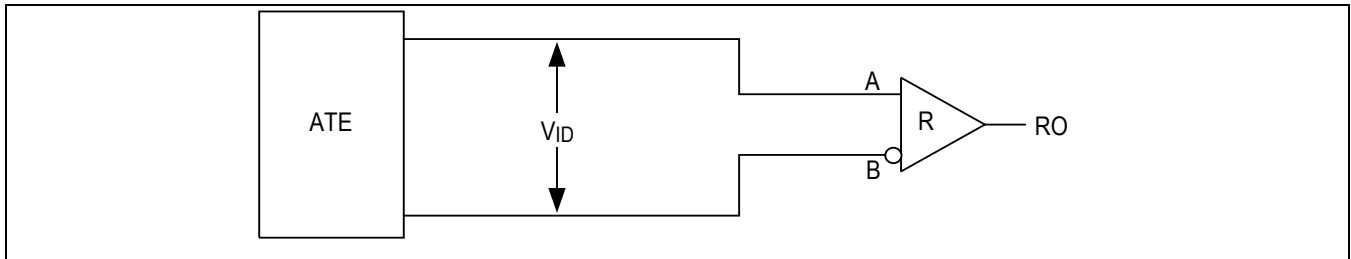

Figure 6. Receiver Propagation Delay Test Circuit

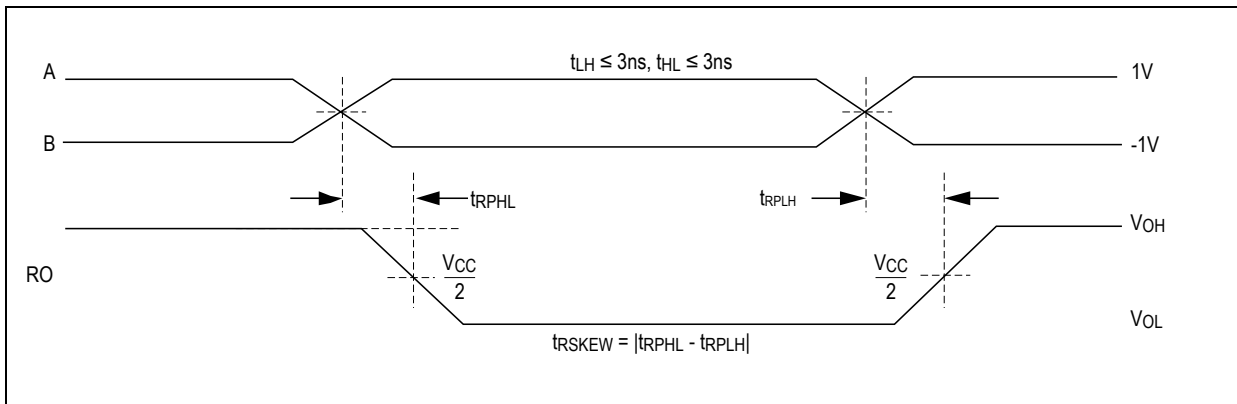

Figure 7. Receiver Propagation Delays

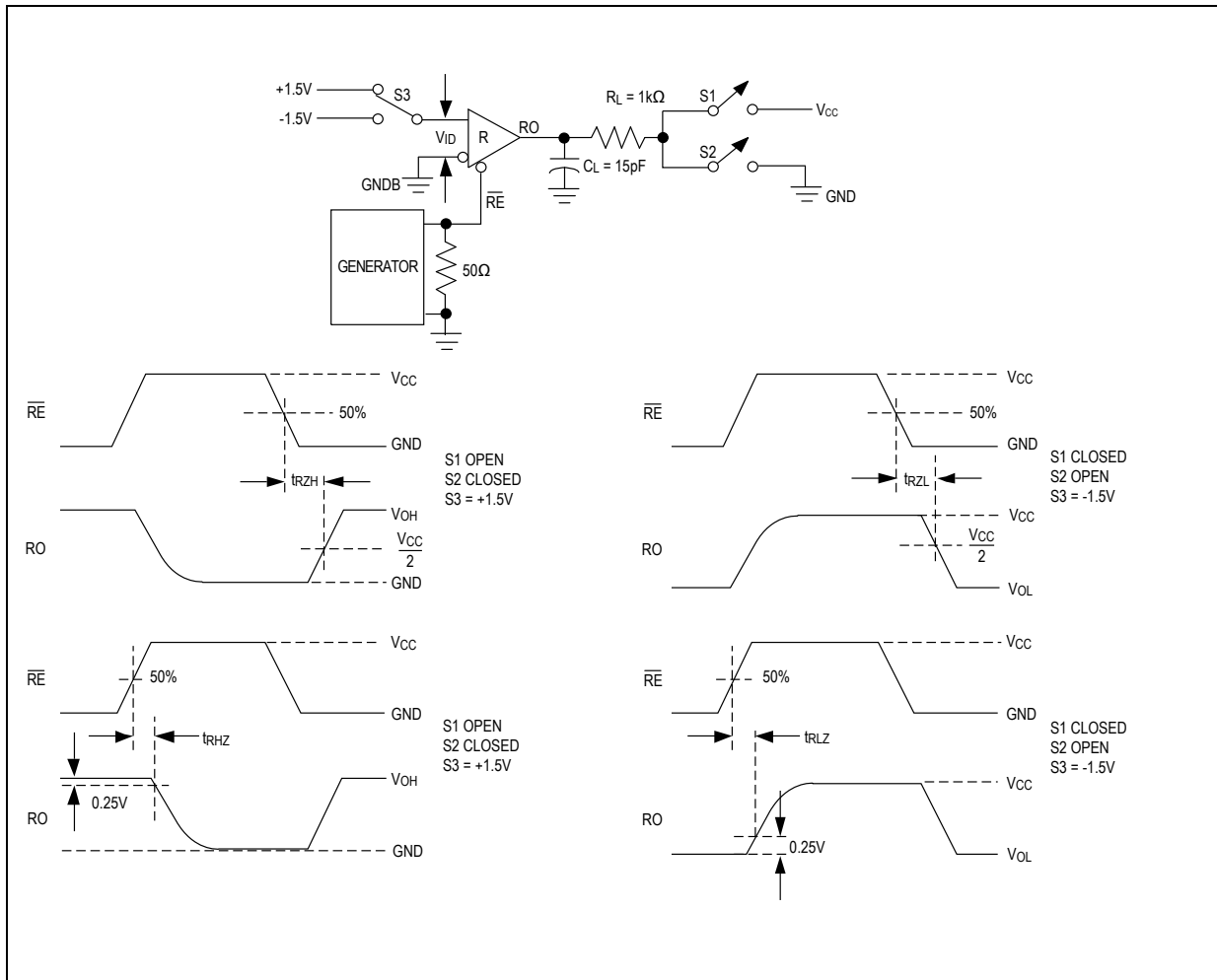

Figure 8. Receiver Enable and Disable Times

+3.3V and +5.0V, RS-485 Half Duplex Transceiver with $\pm 65V$ Fault Protection, $\pm 40V$ CMR, and $\pm 40kV$ ESD

MAX33070E/MAX33071E/MAX33074E

Typical Operating Characteristics

($V_{CC} = 5V$, $T_A = +25^\circ C$, unless otherwise noted.)

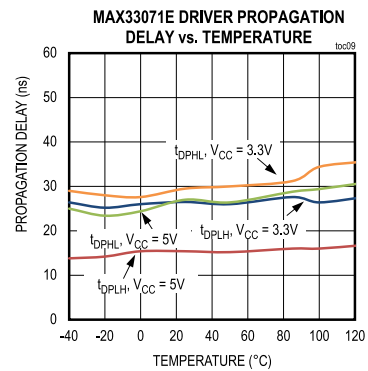
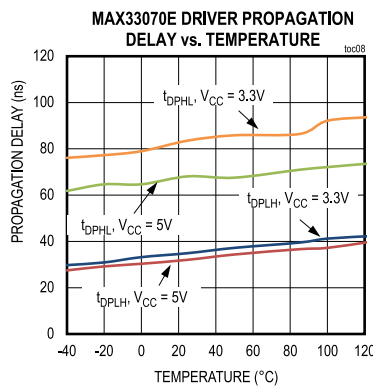
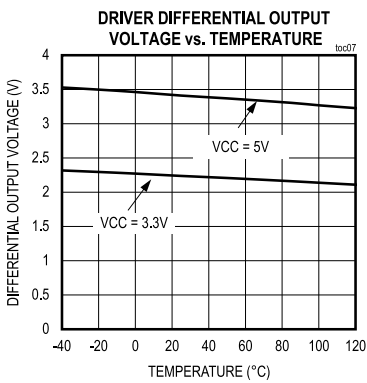
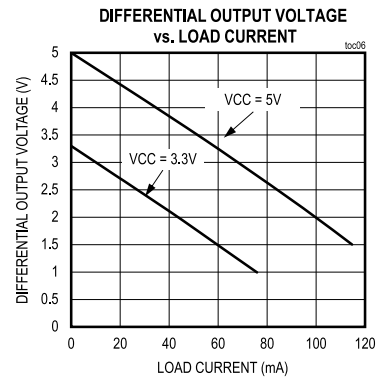
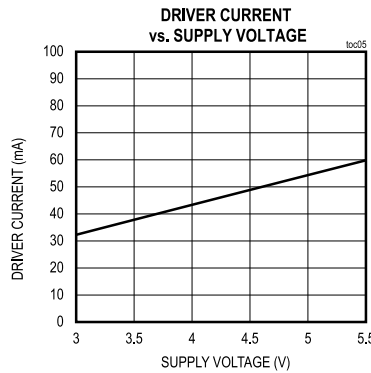
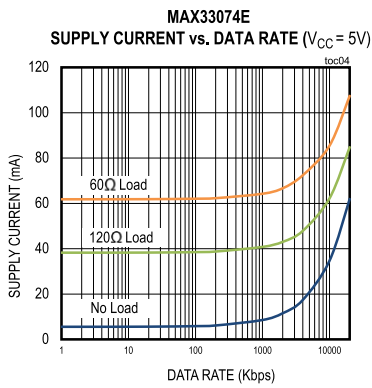
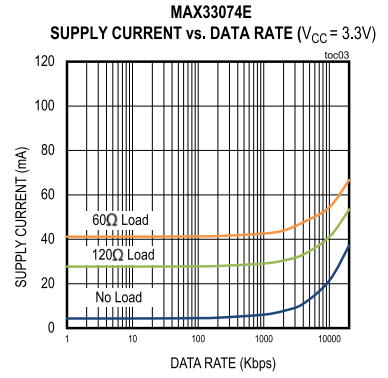
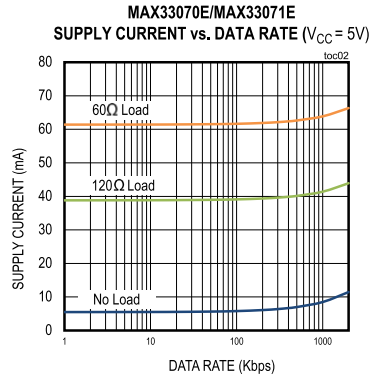
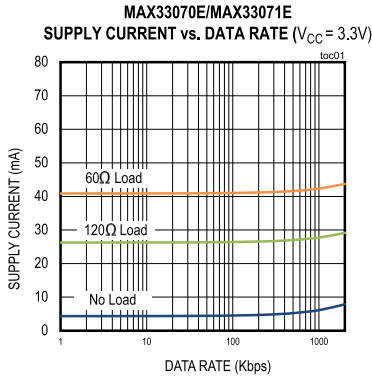

+3.3V and +5.0V, RS-485 Half Duplex Transceiver with $\pm 65V$ Fault Protection, $\pm 40V$ CMR, and $\pm 40kV$ ESD

MAX33070E/MAX33071E/MAX33074E

($V_{CC} = 5V$, $T_A = +25^\circ C$, unless otherwise noted.)

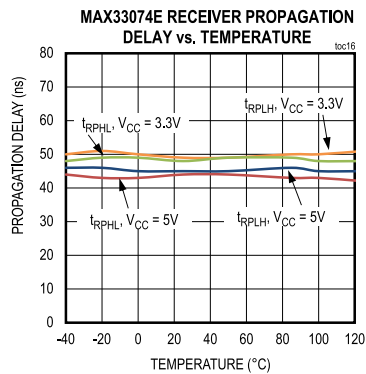
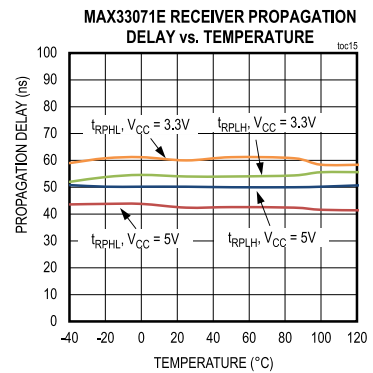
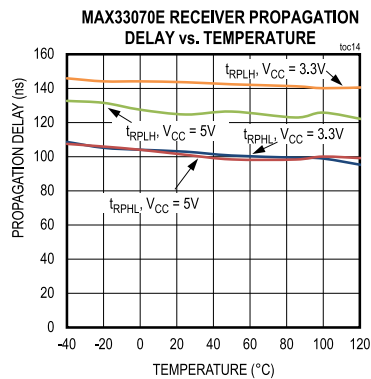
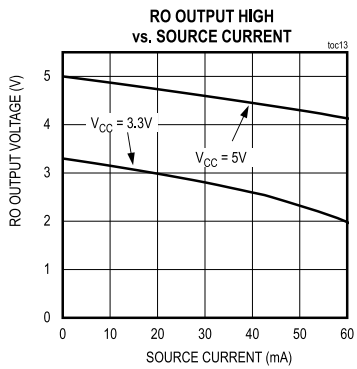
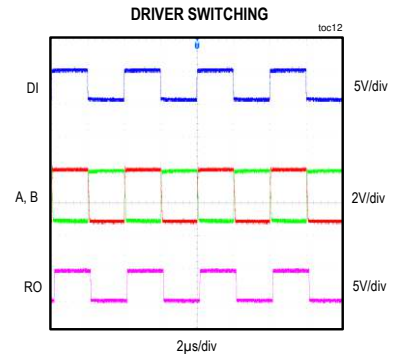
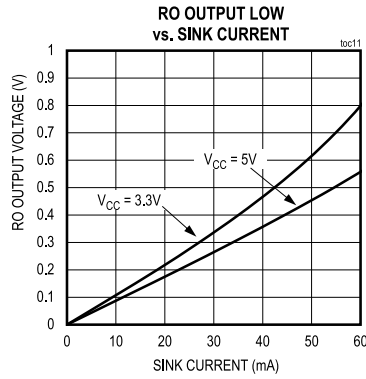
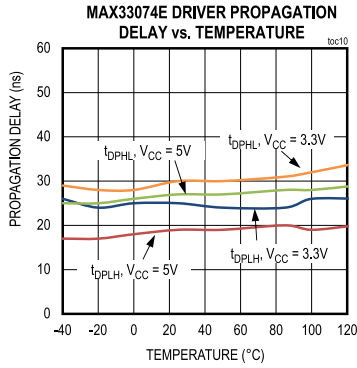

+3.3V and +5.0V, RS-485 Half Duplex Transceiver with $\pm 65\text{V}$ Fault Protection, $\pm 40\text{V}$ CMR, and $\pm 40\text{kV}$ ESD

MAX33070E/MAX33071E/MAX33074E

Pin Configuration

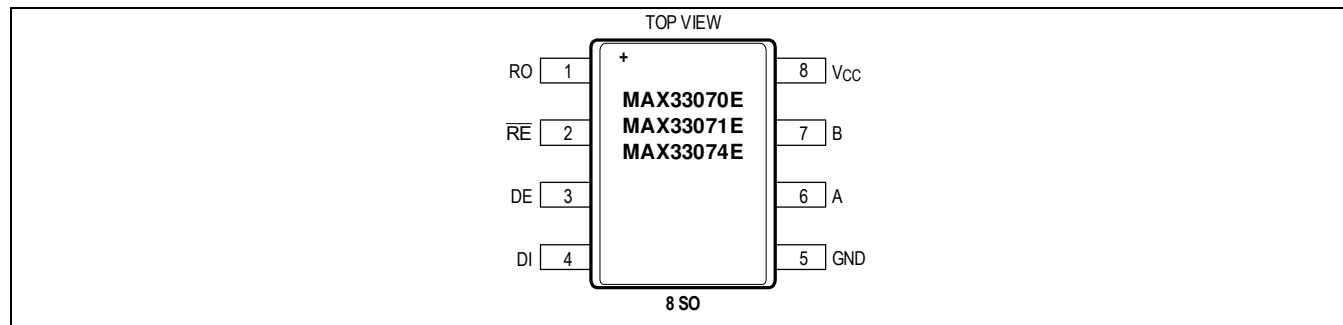

Pin Descriptions

PIN	NAME	FUNCTION
1	RO	Receiver Data Output. See the Receiver Truth Table for more information.
2	$\overline{\text{RE}}$	Receiver Output Enable. Drive $\overline{\text{RE}}$ low or connect to GND to enable RO. Drive $\overline{\text{RE}}$ high to disable the receiver. RO is high impedance when $\overline{\text{RE}}$ is high. Drive $\overline{\text{RE}}$ high and DE low to force the IC into low-power shutdown mode.
3	DE	Driver Output Enable. Drive DE high to enable the driver. Drive DE low or connect to GND to disable the driver. Receiver is always enabled.
4	DI	Driver Input. See the Transmitter Truth Table for more information.
5	GND	Ground
6	A	Noninverting Driver Output/Receiver Input.
7	B	Inverting Driver Output/Receiver Input.
8	VCC	Power Supply Input. Bypass VCC to GND with a 0.1 μF capacitor as close as possible to the device.

Detailed Description

The MAX33070E/MAX33071E/MAX33074E half-duplex transceivers are optimized for RS-485/RS-422 applications that require $\pm 65V$ protection from faults on communication bus lines. These devices contain one differential driver and one differential receiver. These devices feature a 1/8unit load, allowing up to 256 transceivers on a single bus. The MAX33070E supports a data rate up to 500kbps, the MAX33071E up to 2Mbps, and the MAX33074E up to 20 Mbps.

Driver

The driver accepts a single-ended, logic-level input (DI) and transfers it to a differential RS-485 level output on the A and B driver outputs. Set the driver enable input (DE) low to disable the driver. A and B are high impedance when the driver is disabled.

Table 1. Transmitter Truth Table

\overline{RE}	DE	DI	A	B
X	1	0	0	1
X	1	1	1	0
0	0	X	High-Z	High-Z
1	0	X	High-Z	High-Z

Receiver

The receiver accepts a differential, RS-485 level on the A and B inputs and transfers it to a single-ended, logic-level output (RO). Drive the receiver enable input (\overline{RE}) low to enable the receiver. Drive \overline{RE} logic high to disable the receiver. RO is high impedance when \overline{RE} is logic high.

Table 2. Receiver Truth Table

\overline{RE}	DE	($V_A - V_B$)	RO
0	X	$\geq -40mV$	1
0	X	$\leq -200mV$	0
0	X	Open/shorted	1
1	1	X	High-Z
1	0	X	High-Z and shutdown

Low-Power Shutdown

Drive DE low and \overline{RE} high for at least 800ns to put the MAX33070E/MAX33071E/MAX33074E into low-power shutdown mode. The supply current reduces to 4 μA when the device is in shutdown mode. A glitch-protection feature ensures this family of transceivers will not accidentally enter shutdown mode due to logic skews between DE and \overline{RE} when switching between transmit and receive modes.

$\pm 65V$ Fault Protection

The driver outputs/receiver inputs of transceivers connected to an industrial RS-485 network often experience faults when shorted to voltages that exceed the -7V to +12V input range specified in the EIA/TIA-485 standard. Under such circumstances, ordinary RS-485 transceivers that have a typical absolute maximum voltage rating of -8V to +12.5V require costly external protection devices which can compromise the RS-485 performance. To reduce system complexity and the need for external protection, the driver outputs/receiver inputs of the MAX33070E/MAX33071E/MAX33074E are designed to withstand voltage faults of up to $\pm 65V$ with respect to ground without damage. Protection is guaranteed regardless whether the transceiver is active, in shutdown, or without power. When a fault is detected on A or B, the affected driver output is switched into a high-impedance state. After 300ms (typ), the driver output is re-enabled for 30 μ s (typ). If the fault condition persists, the driver output is again disabled. If the fault has been removed, the driver outputs remain on and the transceiver operates normally. Driving a non-terminated cable may cause the voltage seen at the driver outputs (A or B) to exceed the absolute maximum voltage rating if the DI input is switched during a $\pm 65V$ fault on the A or B pins. Therefore, a termination resistor is recommended in order to maximize the overvoltage fault protection while the DI input is being switched. If the DI input does not change state while the fault condition is present, the MAX33070E/MAX33071E/MAX33074E will withstand up to $\pm 65V$ on the RS-485 inputs, regardless of the termination status of the data cable.

$\pm 40V$ Common-Mode Range

RS-485 standards define the common-mode range as -7V to +12V for the receiver. For this family of transceivers, the common-mode range exceeds the standard with $\pm 40V$ for both the driver and receiver. This feature was specifically designed for systems where there is a large common-mode voltage present due to either nearby electrically noisy equipment or large ground differences due to different earth grounds or different power transformers. Two-way communication is possible with $\pm 40V$ high common-mode range where other standard RS-485 transceivers would either fail, not transmit or receive, and/or cause data errors.

True Fail-Safe

The MAX33070E/MAX33071E/MAX33074E guarantees a logic-high receiver output when the receiver inputs are shorted or open, or when they are connected to a terminated transmission line with all drivers disabled. If the differential receiver input voltage ($V_A - V_B$) is greater than or equal to -50mV, RO is logic-high when \overline{RE} is logic-low.

Hot-Swap Inputs

Inserting circuit boards into a hot, or powered backplane may cause voltage transients on DE, and receiver inputs A and B, that can lead to data errors. For example, upon initial circuit board insertion, the processor undergoes a power-up sequence. During this period, the high impedance state of the output drivers makes them unable to drive the MAX33070E/MAX33071E/MAX33074E DE input to a defined logic level. Meanwhile, leakage currents of up to 10 μ A from the high-impedance output, or capacitively coupled noise from V_{CC} or GND, could cause an input to drift to an incorrect logic state. To prevent such a condition from occurring, the MAX33070E/MAX33071E/MAX33074E features hot-swap input circuitry on DE to safeguard against unwanted driver activation during hot-swap situations. When V_{CC} rises, an internal pulldown circuit holds DE low for at least 10 μ s. After the first transition on DE, the internal pulldown/pullup circuitry becomes transparent, resetting the hot-swap tolerable inputs.

Thermal-Shutdown Protection

The MAX33070E/MAX33071E/MAX33074E feature thermal-shutdown protection circuitry to protect the device. When the internal silicon junction temperature exceeds +160°C (typ), the driver outputs are disabled and RO is high impedance. Driver and receiver outputs are re-enabled when the junction temperature falls below +148°C (typ).

Applications Information

256 Transceivers on the Bus

The MAX33070E/MAX33071E/MAX33074E transceivers have 1/8 unit load receiver, allowing for up to 256 transceivers connected in parallel on a shared communication line. Connect any combination of these devices, and/or other RS-485 devices, for a maximum of 32 unit loads on the line.

Typical Application

The MAX33070E/MAX33071E/MAX33074E half-duplex transceivers are designed for bidirectional data communications on multipoint bus transmission lines. The *Typical Application Circuit* shows a typical network application's circuit. To minimize reflections, the bus should be terminated at the receiver inputs in its characteristic impedance, and stub lengths off the main line should be kept as short as possible.

Power Considerations for the MAX33070E/MAX33071E/MAX33074E

At high data rates, the power dissipation of a half-duplex transceiver is determined by a number of factors, including the:

- Data rate
- Time that the driver is transmitting
- Termination impedance
- Power supply voltage
- External common-mode voltage

Higher data rates result in higher power dissipation due to switching losses in the transceiver. Switching losses increase even more when capacitance is applied to the A and B pins. External capacitance should be kept to a minimum to help reduce power dissipations at high data rates. Similarly, the power dissipation in a transceiver is much higher when the driver is transmitting, compared to when the transceiver is receiving. In half-duplex communication, the period of transmission relative to the idle or receiving intervals (i.e., the duty cycle) should be taken into consideration when calculating the average power dissipation. The line termination resistance/impedance determines the driver's load current during transmission and the differential output voltage (V_{OD}) on the driver is determined by the supply voltage. A higher supply voltage results in a larger differential output voltage at the driver driving the line, which in turn results in a higher current draw from the supply (I_{CC}). The power dissipation in the chip is calculated as the product of supply current times supply voltage, subtracting the power dissipated in the external termination resistor. If there is a common-mode voltage (higher than V_{CC}) present (Figure 1b), the transceiver will pull this voltage down to operating levels by sinking current into the A pin (or B pin, whichever is lower). This is factored into the following equation:

$$P_{DIS} = (V_{CC} \times I_{CC}) - (V_{OD}^2/R_L) + (V_{AB} \times I_{AB})$$

where $I_{AB} = ((V_{CM} - V_{AB})/375) + ((V_{CC} - V_{AB})/R_L)$.

Use the *Typical Operating Characteristics* to determine the supply current at a given supply voltage and data rate. For example, assuming a data rate of 500kbps with a 5V supply on a fully loaded bus with +40V common mode (Figure 1b), and assuming $V_{AB} = 1.5V$ (the lower of A, B), we can calculate that the power dissipation (at room temperature) is:

$$P_{DIS} = (5V \times 65mA) - (3.4V^2/60\Omega) + (1.5V \times 160mA) = 564mW$$

Ensure that power dissipation of the transceiver is kept below the value listed in the *Absolute Maximum Ratings* to protect the device from entering thermal shutdown or from damage.

PCB Layout Considerations

PCB layout can affect the performance of the transceiver in conditions with high common-mode voltage at a high ambient temperature. In order to maximize thermal dissipation, it is recommended to:

1. Use large copper pads for all the pins.
2. Connect the GND pad to a large copper plane on the same layer or through vias to the bottom layer.

ESD Protection

ESD protection structures are incorporated on all pins to protect against electrostatic discharge encountered during handling and assembly. The driver outputs and receiver inputs (A and B data lines) of the MAX33070E/MAX33071E/MAX33074E have extra protection against static electricity. The ESD structures withstand high ESD in normal operation and when powered down. After an ESD event, the devices keep working without latch-up or damage.

ESD protection can be tested in various ways. The transmitter outputs and receiver inputs (A and B data lines) of the devices are characterized for protection to the cable-side ground (GNDB) to the following limits:

- $\pm 40\text{kV}$ HBM per JEDEC JS-001-2017
- $\pm 15\text{kV}$ using the Air-Gap Discharge method specified in the IEC 61000-4-2
- $\pm 10\text{kV}$ using the Contact Discharge method specified in the IEC 61000-4-2

The other non-data pins are also ESD protected, but at a lower level per the *Electrical Characteristics* table.

ESD Test Conditions

ESD performance depends on a variety of conditions. Contact Maxim for a reliability report that documents test setup, test methodology, and test results.

Human Body Model (HBM)

[Figure 9](#) shows the HBM test model and [Figure 10](#) shows the current waveform it generates when discharged in a low-impedance state. This model consists of a 100pF capacitor charged to the ESD voltage of interest, which is then discharged into the test device through a $1.5\text{k}\Omega$ resistor.

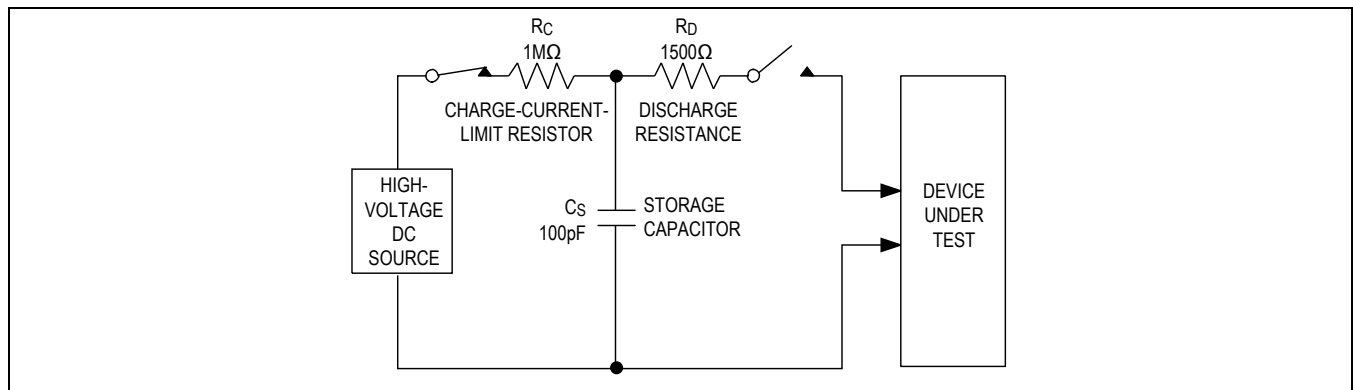

Figure 9. Human Body ESD Test Model

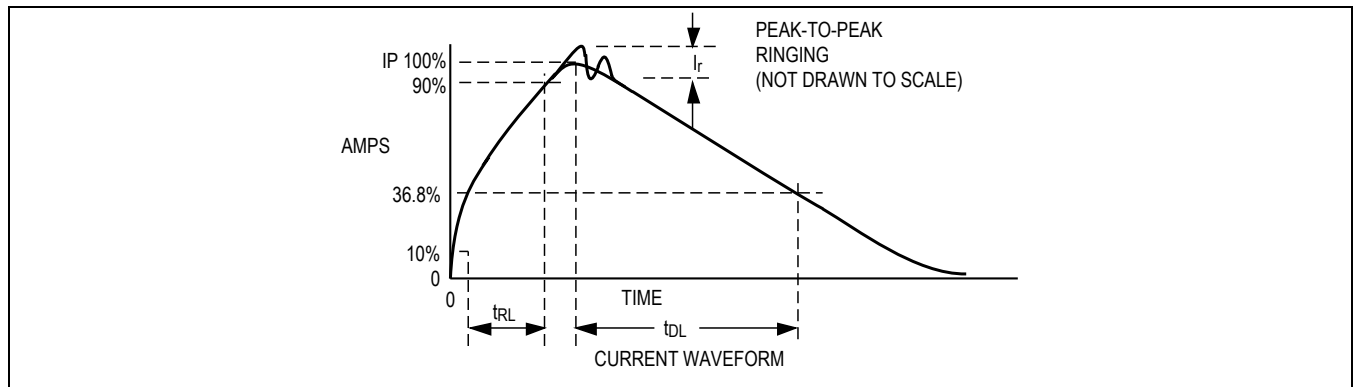

Figure 10. Human Body Current Waveform

IEC 61000-4-2

The IEC 61000-4-2 standard covers ESD testing and performance of finished equipment. However, it does not specifically refer to integrated circuits. The MAX33070E/MAX33071E/MAX33074E help in designing equipment to meet IEC 61000-4-2 without the need for additional ESD protection components. The major difference between tests done using the HBM and IEC 61000-4-2 is higher peak current in IEC 61000-4-2 because series resistance is lower in the IEC 61000-4-2 model. Hence, the ESD withstand voltage measured to IEC 61000-4-2 is generally lower than that measured using the HBM. [Figure 11](#) shows the IEC 61000-4-2 model and [Figure 12](#) shows the current waveform for IEC 61000-4-2 ESD Contact Discharge, and Air-Gap tests.

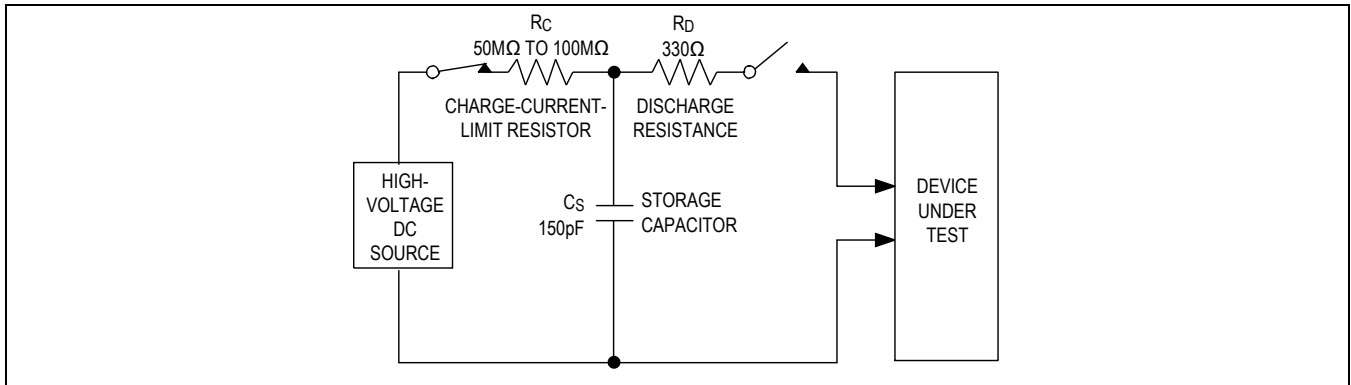

Figure 11. IEC 61000-4-2 ESD Test Model

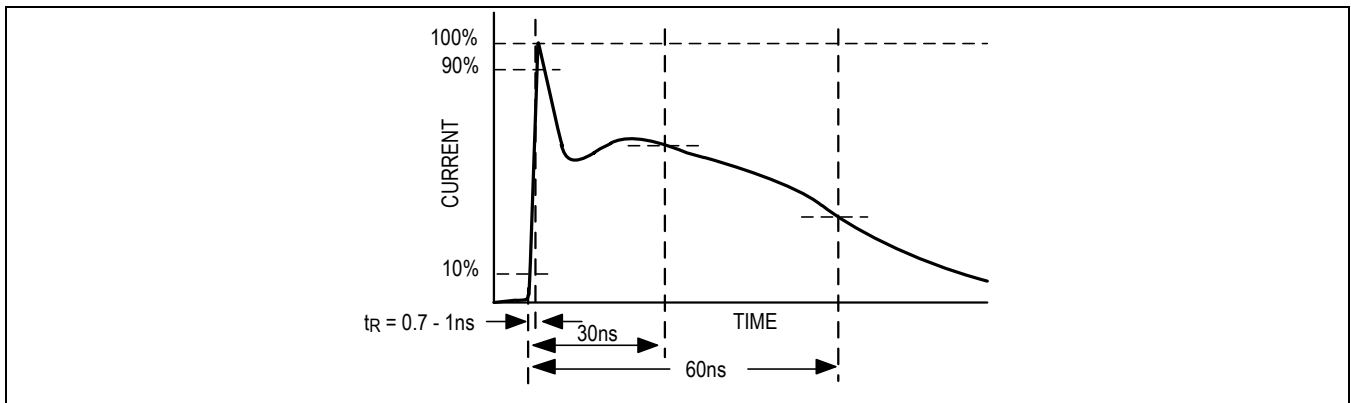

Figure 12. IEC 61000-4-2 ESD Generator Current Waveform

+3.3V and +5.0V, RS-485 Half Duplex Transceiver with $\pm 65\text{V}$ Fault Protection, $\pm 40\text{V}$ CMR, and $\pm 40\text{kV}$ ESD

MAX33070E/MAX33071E/MAX33074E

Typical Application Circuits

Typical RS-485 Network

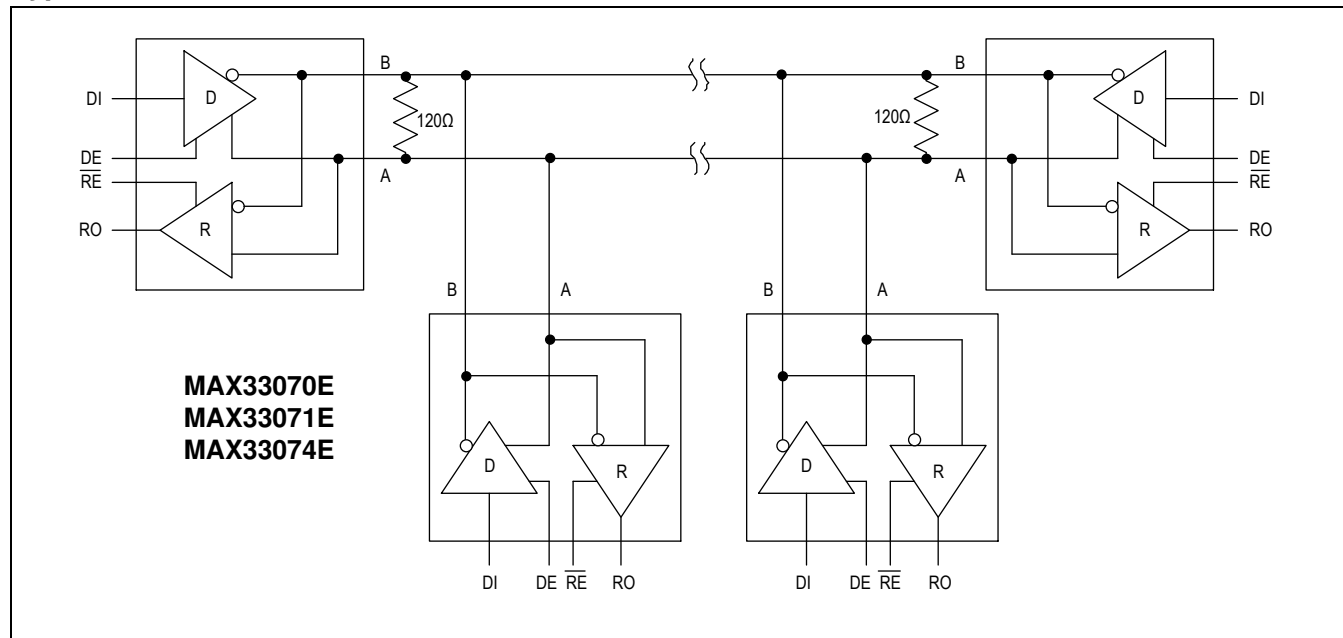

Ordering Information

PART NUMBER	TEMPERATURE RANGE	PIN-PACKAGE	MAXIMUM DATA RATE
MAX33070EASA+	-40°C to +125°C	8 SO	500kbps
MAX33070EASA+T	-40°C to +125°C	8 SO	500kbps
MAX33071EASA+	-40°C to +125°C	8 SO	2Mbps
MAX33071EASA+T	-40°C to +125°C	8 SO	2Mbps
MAX33074EASA+	-40°C to +125°C	8 SO-EP	20Mbps
MAX33074EASA+T	-40°C to +125°C	8 SO-EP	20Mbps

+ Denotes a lead(Pb)-free/RoHS-compliant package.

T = Tape and reel.

+3.3V and +5.0V, RS-485 Half Duplex
Transceiver with $\pm 65V$ Fault Protection,
 $\pm 40V$ CMR, and $\pm 40kV$ ESD

MAX33070E/MAX33071E/MAX33074E

Revision History

REVISION NUMBER	REVISION DATE	DESCRIPTION	PAGES CHANGED
0	1/21	Initial release	—
1	7/21	Updated Typical Operating Characteristics and <i>Ordering Information</i> table, corrected a typo	7, 11, 12, 18
2	4/22	Updated <i>Electrical Characteristics</i> table and Table 2	6, 16

