

## Silicon Fast Recovery Diode

$V_{RRM} = 50\text{ V} - 400\text{ V}$

$I_F = 6\text{ A}$

### Features

- High Surge Capability
- Types from 50 V to 400 V  $V_{RRM}$
- Not ESD Sensitive

### Note:

1. Standard polarity: Stud is cathode.
2. Reverse polarity (R): Stud is anode.
3. Stud is base.

DO-4 Package

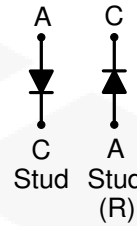

### Maximum ratings, at $T_j = 25\text{ }^\circ\text{C}$ , unless otherwise specified ("R" devices have leads reversed)

| Parameter  | Symbol     | Conditions   | FR6A(R)05  | FR6B(R)05  | FR6D(R)05  | FR6G(R)05  | Unit             |
|--|------------|--|------------|------------|------------|------------|------------------|
| Repetitive peak reverse voltage                      | $V_{RRM}$  |  | 50         | 100        | 200        | 400        | V                |
| RMS reverse voltage                                  | $V_{RMS}$  |  | 35         | 70         | 140        | 280        | V                |
| DC blocking voltage                                  | $V_{DC}$   |  | 50         | 100        | 200        | 400        | V                |
| Continuous forward current                           | $I_F$      | $T_C \leq 100\text{ }^\circ\text{C}$                     | 16         | 16         | 16         | 16         | A                |
| Surge non-repetitive forward current, Half Sine Wave | $I_{F,SM}$ | $T_C = 25\text{ }^\circ\text{C}$ , $t_p = 8.3\text{ ms}$ | 135        | 135        | 135        | 135        | A                |
| Operating temperature                                | $T_j$      |  | -55 to 150 | -55 to 150 | -55 to 150 | -55 to 150 | $^\circ\text{C}$ |
| Storage temperature                                  | $T_{stg}$  |  | -55 to 150 | -55 to 150 | -55 to 150 | -55 to 150 | $^\circ\text{C}$ |

### Electrical characteristics, at $T_j = 25\text{ }^\circ\text{C}$ , unless otherwise specified

| Parameter             | Symbol | Conditions  | FR6A(R)05 | FR6B(R)05 | FR6D(R)05 | FR6G(R)05 | Unit          |
|-----------------------|--------|---|-----------|-----------|-----------|-----------|---------------|
| Diode forward voltage | $V_F$  | $I_F = 6\text{ A}$ , $T_j = 25\text{ }^\circ\text{C}$   | 1.4       | 1.4       | 1.4       | 1.4       | V             |
| Reverse current       | $I_R$  | $V_R = 50\text{ V}$ , $T_j = 25\text{ }^\circ\text{C}$  | 25        | 25        | 25        | 25        | $\mu\text{A}$ |
|                       |        | $V_R = 50\text{ V}$ , $T_j = 150\text{ }^\circ\text{C}$ | 6         | 6         | 6         | 6         | mA            |

### Recovery Time

|                               |          |   |     |     |     |     |    |
|-------------------------------|----------|---|-----|-----|-----|-----|----|
| Maximum reverse recovery time | $T_{RR}$ | $I_F = 0.5\text{ A}$ , $I_R = 1.0\text{ A}$ ,<br>$I_{RR} = 0.25\text{ A}$ | 500 | 500 | 500 | 500 | nS |
|-------------------------------|----------|---|-----|-----|-----|-----|----|

### Thermal characteristics

|                                     |            |  |     |     |     |     |                    |
|-------------------------------------|------------|--|-----|-----|-----|-----|--------------------|
| Thermal resistance, junction - case | $R_{thJC}$ |  | 2.5 | 2.5 | 2.5 | 2.5 | $^\circ\text{C/W}$ |
|-------------------------------------|------------|--|-----|-----|-----|-----|--------------------|

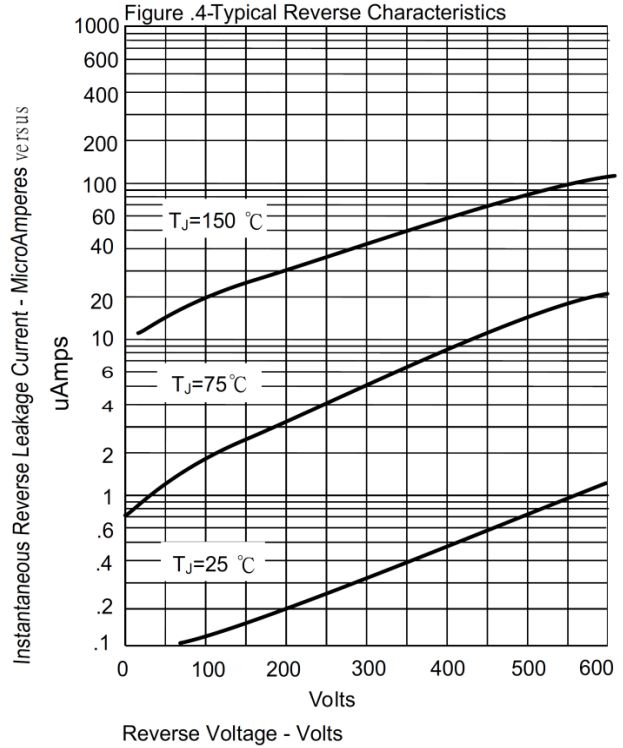
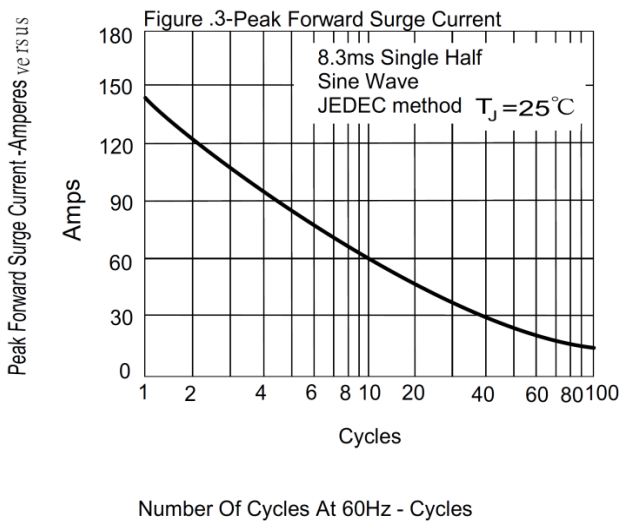
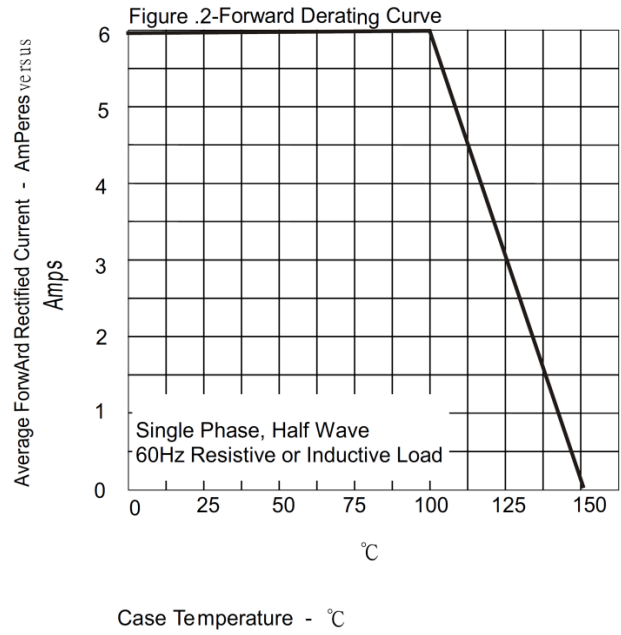
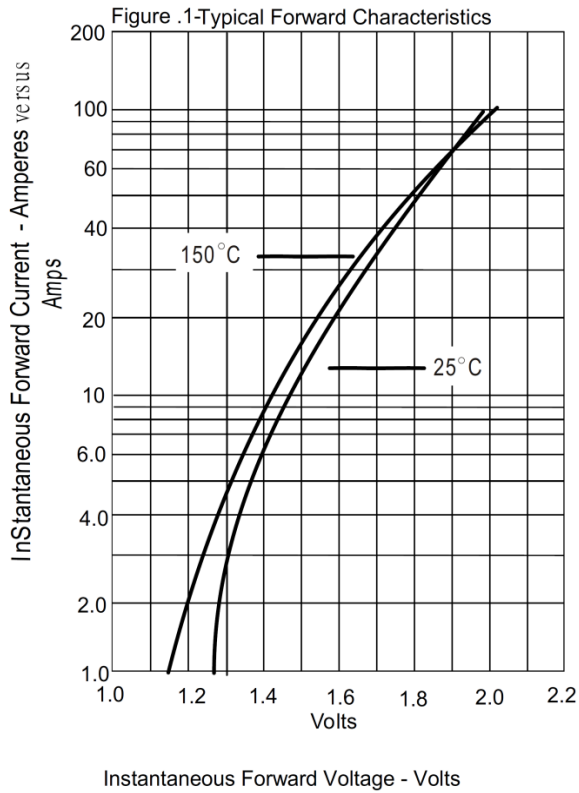

**Package dimensions and terminal configuration**

Product is marked with part number and terminal configuration.

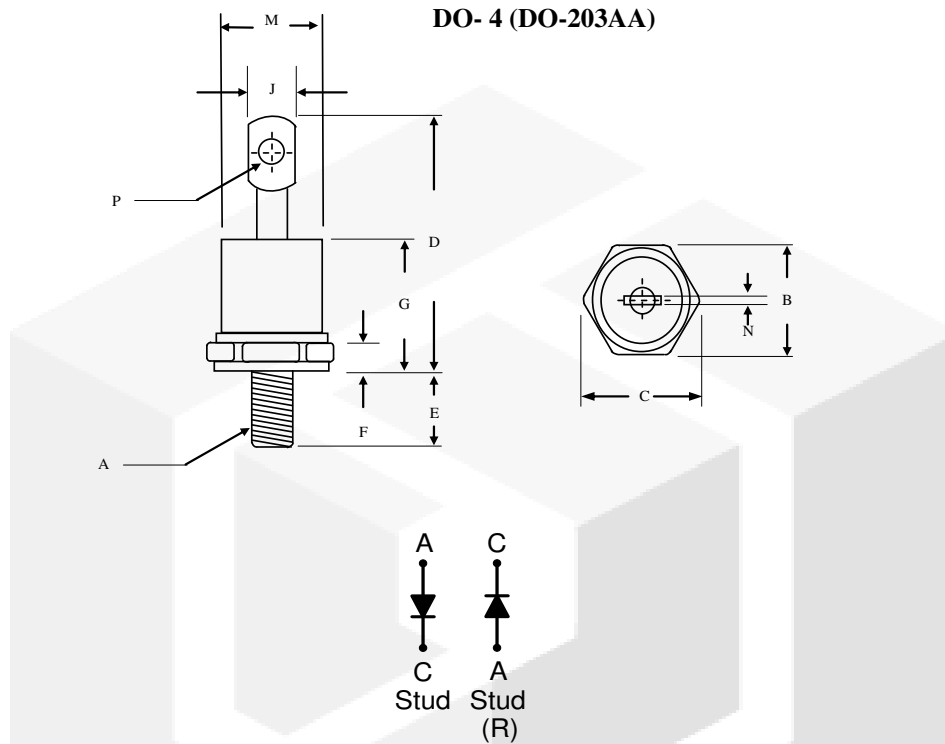

|   | Inches    |        | Millimeters |       |
|---|-----------|--------|-------------|-------|
|   | Min       | Max    | Min         | Max   |
| A | 10-32 UNF |        |             |       |
| B | 0.424     | 0.437  | 10.77       | 11.10 |
| C | -----     | 0.505  | -----       | 12.82 |
| D | -----     | 0.800  | -----       | 20.30 |
| E | 0.453     | 0.492  | 11.50       | 12.50 |
| F | 0.114     | 0.140  | 2.90        | 3.50  |
| G | -----     | 0.405  | -----       | 10.29 |
| J | -----     | 0.216  | -----       | 5.50  |
| M | -----     | φ0.302 | -----       | φ7.68 |
| N | 0.031     | 0.045  | 0.80        | 1.15  |
| P | 0.070     | 0.79   | 1.80        | 2.00  |