





## Zirconia O<sub>2</sub> Sensors Oxygen Measurement System

### FEATURES

- Fast response zirconium dioxide (ZrO<sub>2</sub>) sensor in conjunction with the OXY-LC oxygen sensor interface board
- Long life, non-depleting technology
- Integral heating element
- High accuracy
- Linear output signal

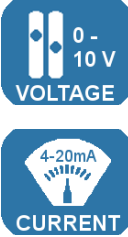

<p><b>Supply Voltage</b></p>  <p>24 V VOLTAGE</p>	<p><b>Gas Temp</b></p>  <p>-100°C to +250°C TEMPERATURE</p>	<p><b>Digital Output</b></p>  <p>RS485 PWM</p>	<p><b>Analogue Output</b></p>  <p>0 - 10 V VOLTAGE 4-20mA CURRENT</p>	<p><b>Response Time</b></p>  <p>&lt; 4 secs</p>
---	---	--	---	---

### BENEFITS

- No reference gas required
- No need for temperature stabilisation
- Variety of probe mounting positions available; 28mm, 45mm & 55mm
- M18x1.5 screw mounting

### OUTPUT VALUES

Oxygen range (analogue output)	0.1—25% O <sub>2</sub> or 0.1—100% O <sub>2</sub>
Oxygen range (Modbus RTU)	0.1—100% O <sub>2</sub>
Accuracy after calibration	0.5% O <sub>2</sub>
Accuracy after calibration	0.5% O <sub>2</sub>
Output resolution	0.01% O <sub>2</sub>
Response time (10—90% step)	< 4s
Initial warm up time (till stable output)	5—10mins
Output inactive start up delay (heater warm up)	
From OFF to ON mode:	60s
From Standby to ON mode (RS485 only):	20s

### TECHNICAL SPECIFICATIONS

Supply voltage	
RS485 output variant:	8—28V <sub>DC</sub>
Analogue output variants:	20—28V <sub>DC</sub>
Supply current	600mA max. at 24V <sub>DC</sub> 1.2A max. at 12V <sub>DC</sub>
Digital output	RS485 (Modbus RTU)
Analogue output	4—20mA; load 600Ω max or 0—10V <sub>DC</sub> ; load 10kΩ min
Pump impedance at 700°C <sup>1</sup>	< 6kΩ
Permissible gas temperature	-100°C to +250°C
Gas flow rate <sup>2</sup>	0—10m/s
Operating pressure limits <sup>3</sup>	260—1260mbar absolute
Mounting thread	M18 x 1.5

**Need help? Ask the expert**  
Tel: + 44 (0)1236 459 020  
and ask for “Technical”



### NOTES

- 1) The constant current source used in the pump circuit should be designed to drive a load of up to 6kΩ.
- 2) With baffle fitted to shield the sensor from direct cooling and pollution by the flue gas; refer to DS0122 ZrO<sub>2</sub> Screw Fit Probe Datasheet for fitment details.
- 3) Sensor and interface for correct barometric pressure compensation.

## DESCRIPTION

The Oxygen Measurement System is a complete solution consisting of a zirconium dioxide oxygen sensor and interface PCB. Dimensional overview given below; full specifications for each, including complete outline drawing and electrical interface details can be found:

- [DS0122 ZrO<sub>2</sub> Screw Fit Probe Datasheet](#)
- [DS0058 OXY-LC Oxygen Sensor Interface Datasheet](#)

Contact [technical@sstsensing.com](mailto:technical@sstsensing.com) for details.

### Interface Board layout

 Always handle the interface board using the correct ESD handling precautions.

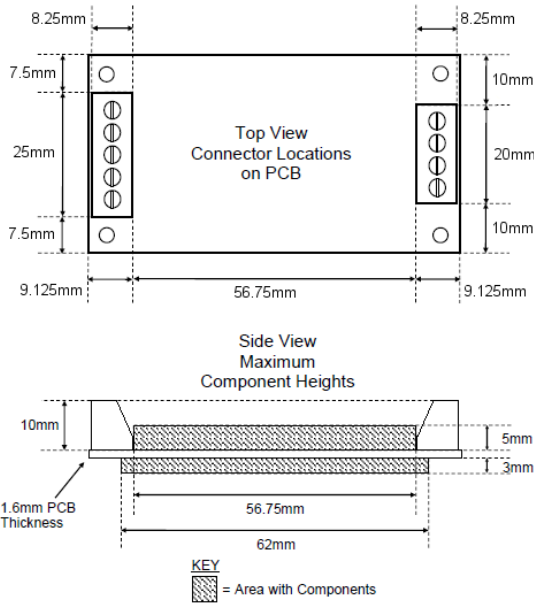

### Sensor layout

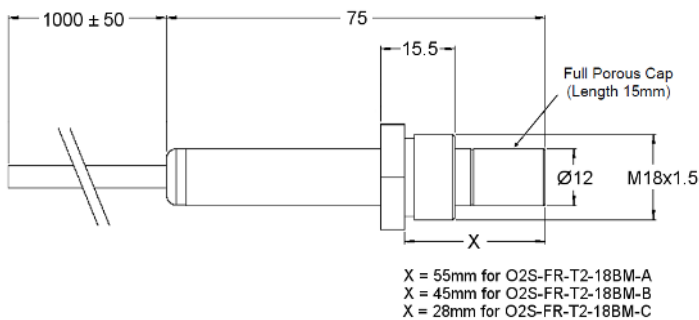

## ORDER INFORMATION

Referring to the tables below will allow you to tailor a system to suit your specific requirements.

For example: Ordering part numbers *OXY-LC-A25-455* and *O2S-FR-T2-18BM-C* will create a system that has a 4—20mA analogue output from the board and a sensor probe that has a length of 28mm from the sensor tip to the beginning of the M18x1.5 screw mount.

### Interface Board

PCB Part Number	O <sub>2</sub> Measure Range	Output Type	Heater Voltage
<b>OXY-LC-485</b>	0.1% and 100%	Modbus RTU	Configurable
<b>OXY-LC-A25-455</b>	0.1 to 25%	Current: 4—20mA	4.55V <sub>DC</sub>
<b>OXY-LC-V25-455</b>	0.1 to 25%	Voltage: 0—10V <sub>DC</sub>	4.55V <sub>DC</sub>
<b>OXY-LC-A100-455</b>	0.1 to 100%	Current: 4—20mA	4.55V <sub>DC</sub>
<b>OXY-LC-V100-455</b>	0.1 to 100%	Voltage: 0—10V <sub>DC</sub>	4.55V <sub>DC</sub>

### Sensor

Sensor Part Number	Probe Length
<b>O2S-FR-T2-18BM-A</b>	55mm
<b>O2S-FR-T2-18BM-B</b>	45mm
<b>O2S-FR-T2-18BM-C</b>	28mm

### CAUTION

Do not exceed maximum ratings and ensure sensor(s) are operated in accordance with their requirements. Carefully follow all wiring instructions. Incorrect wiring can cause permanent damage to the device. Zirconium dioxide sensors are damaged by the presence of silicone. Vapours (organic silicone compounds) from RTV rubbers and sealants are known to poison oxygen sensors and MUST be avoided. Do NOT use chemical cleaning agents.

**Failure to comply with these instructions may result in product damage.**

### INFORMATION

As customer applications are outside of SST Sensing Ltd.'s control, the information provided is given without legal responsibility. Customers should test under their own conditions to ensure that the equipment is suitable for their intended application.

For detailed information on the sensor operation refer to application note AN0043 Operating Principle and Construction of Zirconium Dioxide Oxygen Sensors.

**For technical assistance or advice, please email:**  
[technical@sstsensing.com](mailto:technical@sstsensing.com)

**General Note:** SST Sensing Ltd. reserves the right to make changes to product specifications without notice or liability. All information is subject to SST Sensing Ltd.'s own data and considered accurate at time of going to print.