



ANATECH ELECTRONICS INC
RF & Microwave Filters & Products

1 MHz LC Low Pass Filter

Part Number: AE1L7825



Electrical specifications

Cutoff Frequency : 1 MHz

Passband: DC-1 MHz

Insertion loss: <0.8 dB

Return loss: >20 dB

Rejection : ≥ 50 dB @ 1.994-4.012 MHz

Power Handling: 200 Watts

Mechanical

Connector Type: N-Type(F)

Dimensions: 6.00 x 2.00 x 1.50 Inches

Environmental

Operating Temperature: -40°C to +70°C

Storage Temperature: -55°C to +85°C

Shock: 10 G. 11ms

Vibration: 10 G. 5 to 200 Hz

Outline Drawing:

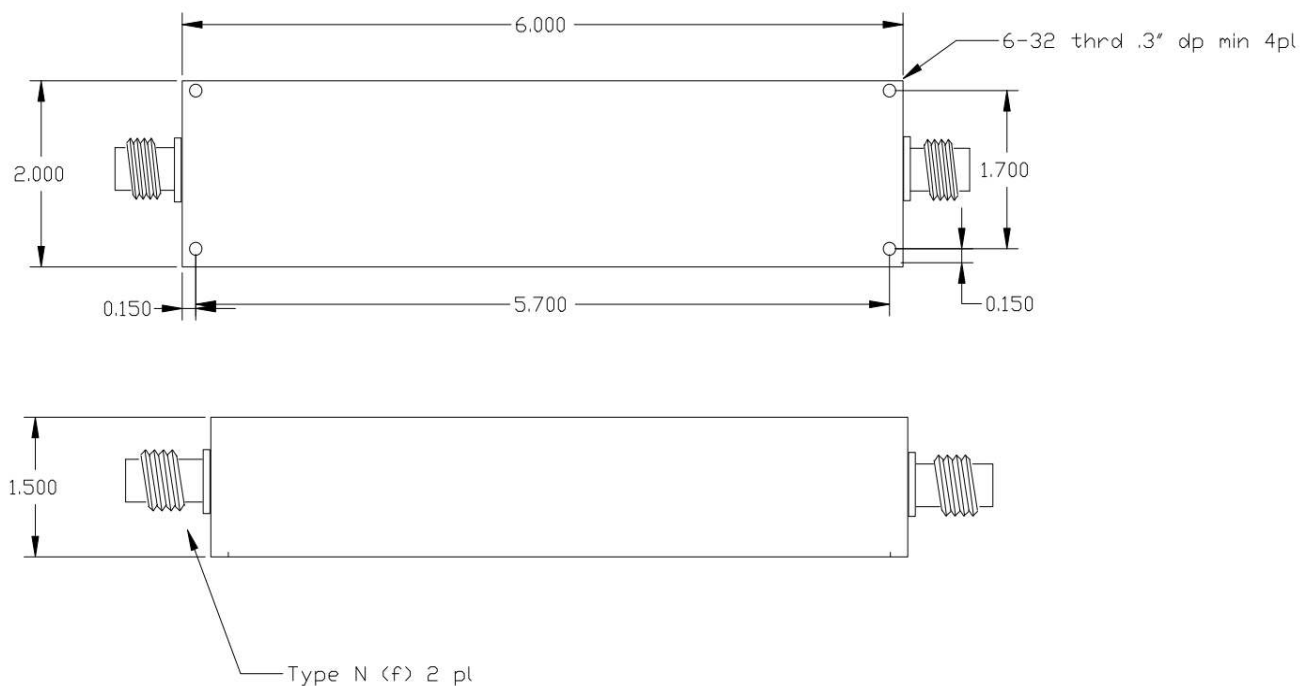

Rev A EDS04142021