

Automotive-grade P-channel -30 V, 5 mΩ typ., -80 A STripFET™ H6 Power MOSFET in a DPAK package

Datasheet - production data

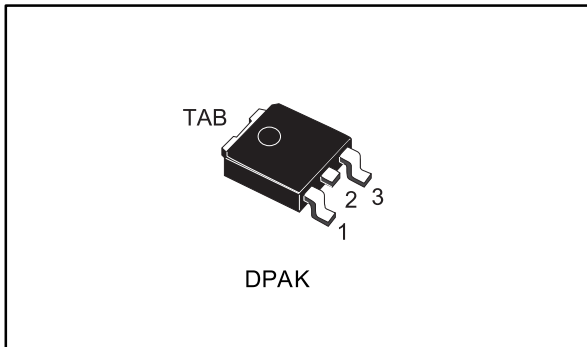
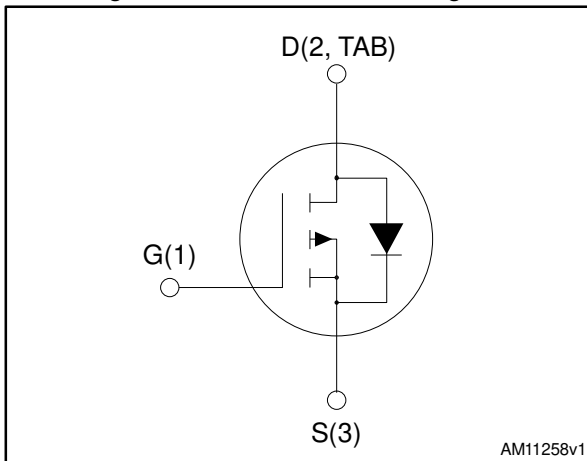

Figure 1: Internal schematic diagram



Features

Order code	V _{DS}	R _{DS(on)} max.	I _D	P _{TOT}
STD95P3LLH6AG	-30 V	6.9 mΩ	-80 A	104 W

- Designed for automotive applications and AEC-Q101 qualified
- Very low on-resistance
- Very low gate charge
- High avalanche ruggedness
- Low gate drive power loss
- Logic level

Applications

- Switching applications

Description

This device is a P-channel Power MOSFET developed using the STripFET™ H6 technology with a new trench gate structure. The resulting Power MOSFET exhibits very low R_{DS(on)} in all packages.

Table 1: Device summary

Order code	Marking	Package	Packing
STD95P3LLH6AG	95P3LLH6	DPAK	Tape and reel

Contents

1	Electrical ratings	3
2	Electrical characteristics	4
	2.1 Electrical characteristics (curves)	6
3	Test circuits	8
4	Package information	9
	4.1 DPAK type A2 package information	10
	4.2 DPAK packing information	13
5	Revision history	15

1 Electrical ratings

Table 2: Absolute maximum ratings

Symbol	Parameter	Value	Unit
V_{DS}	Drain-source voltage	-30	V
V_{GS}	Gate-source voltage	± 18	V
$I_D^{(1)}$	Drain current (continuous) at $T_{case} = 25\text{ }^\circ\text{C}$	-80	A
	Drain current (continuous) at $T_{case} = 100\text{ }^\circ\text{C}$	-80	A
$I_{DM}^{(2)}$	Drain current (pulsed)	-320	A
P_{TOT}	Total dissipation at $T_{case} = 25\text{ }^\circ\text{C}$	104	W
$E_{AS}^{(3)}$	Single pulse avalanche energy	650	mJ
T_{stg}	Storage temperature range	-55 to 150	$^\circ\text{C}$
T_j	Operating junction temperature range		

Notes:

- (1) Limited by wire bonding
- (2) Pulse width is limited by safe operating area.
- (3) starting $T_j = 25\text{ }^\circ\text{C}$, $I_{AS} = -40\text{ A}$, $V_{DD} = -25\text{ V}$

Table 3: Thermal data

Symbol	Parameter	Value	Unit
$R_{thj-case}$	Thermal resistance junction-case	1.2	$^\circ\text{C/W}$
$R_{thj-pcb}^{(1)}$	Thermal resistance junction-pcb	50	

Notes:

- (1) When mounted on a 1-inch² FR-4, 2 Oz copper board

2 Electrical characteristics

($T_{\text{case}} = 25\text{ °C}$ unless otherwise specified)

Table 4: Static

Symbol	Parameter	Test conditions	Min.	Typ.	Max.	Unit
$V_{(\text{BR})\text{DSS}}$	Drain-source breakdown voltage	$V_{\text{GS}} = 0\text{ V}$, $I_{\text{D}} = -1\text{ mA}$	-30			V
I_{DSS}	Zero gate voltage drain current	$V_{\text{GS}} = 0\text{ V}$, $V_{\text{DS}} = -30\text{ V}$			-1	μA
		$V_{\text{GS}} = 0\text{ V}$, $V_{\text{DS}} = -30\text{ V}$, $T_{\text{case}} = 125\text{ °C}^{(1)}$			-10	
I_{GSS}	Gate-body leakage current	$V_{\text{DS}} = 0\text{ V}$, $V_{\text{GS}} = \pm 18\text{ V}$			± 100	nA
$V_{\text{GS}(\text{th})}$	Gate threshold voltage	$V_{\text{DS}} = V_{\text{GS}}$, $I_{\text{D}} = -250\text{ }\mu\text{A}$	-1		-2.5	V
$R_{\text{DS}(\text{on})}$	Static drain-source on-resistance	$V_{\text{GS}} = -10\text{ V}$, $I_{\text{D}} = -40\text{ A}$		5	6.9	m Ω
		$V_{\text{GS}} = -4.5\text{ V}$, $I_{\text{D}} = -40\text{ A}$		7.5	9.7	

Notes:

⁽¹⁾Defined by design, not subject to production test.

Table 5: Dynamic

Symbol	Parameter	Test conditions	Min.	Typ.	Max.	Unit
C_{ISS}	Input capacitance	$V_{\text{DS}} = -25\text{ V}$, $f = 1\text{ MHz}$, $V_{\text{GS}} = 0\text{ V}$	-	6250	-	pF
C_{OSS}	Output capacitance		-	830	-	
C_{RSS}	Reverse transfer capacitance		-	590	-	
Q_{g}	Total gate charge	$V_{\text{DD}} = -15\text{ V}$, $I_{\text{D}} = -80\text{ A}$, $V_{\text{GS}} = -10\text{ V}$ (see Figure 14: "Gate charge test circuit")	-	113	-	nC
Q_{gs}	Gate-source charge		-	18.5	-	
Q_{gd}	Gate-drain charge		-	19	-	

Table 6: Switching on/off (inductive load)

Symbol	Parameter	Test conditions	Min.	Typ.	Max.	Unit
$t_{\text{d}(\text{on})}$	Turn-on delay time	$V_{\text{DD}} = -15\text{ V}$, $I_{\text{D}} = -80\text{ A}$, $R_{\text{G}} = 4.7\text{ }\Omega$, $V_{\text{GS}} = -10\text{ V}$ (see Figure 13: "Switching times test circuit for resistive load")	-	15	-	ns
t_{r}	Rise time		-	30	-	
$t_{\text{d}(\text{off})}$	Turn-off delay time		-	110	-	
t_{f}	Fall time		-	70	-	

Table 7: Source-drain diode

Symbol	Parameter	Test conditions	Min.	Typ.	Max.	Unit
I_{SD}	Source-drain current		-		-80	A
$I_{SDM}^{(1)}$	Source-drain current (pulsed)		-		-320	A
$V_{SD}^{(2)}$	Forward on voltage	$V_{GS} = 0\text{ V}$, $I_{SD} = -80\text{ A}$	-		-1.5	V
t_{rr}	Reverse recovery time	$I_{SD} = -80\text{ A}$, $di/dt = 100\text{ A}/\mu\text{s}$, $V_{DD} = -24\text{ V}$ (see Figure 15: "Test circuit for inductive load switching and diode recovery times")	-	27		ns
Q_{rr}	Reverse recovery charge		-	17		nC
I_{RRM}	Reverse recovery current		-	-1.2		A

Notes:

- (1) Pulse width is limited by safe operating area.
(2) Pulse test: pulse duration = 300 μs , duty cycle 1.5%.

2.1 Electrical characteristics (curves)

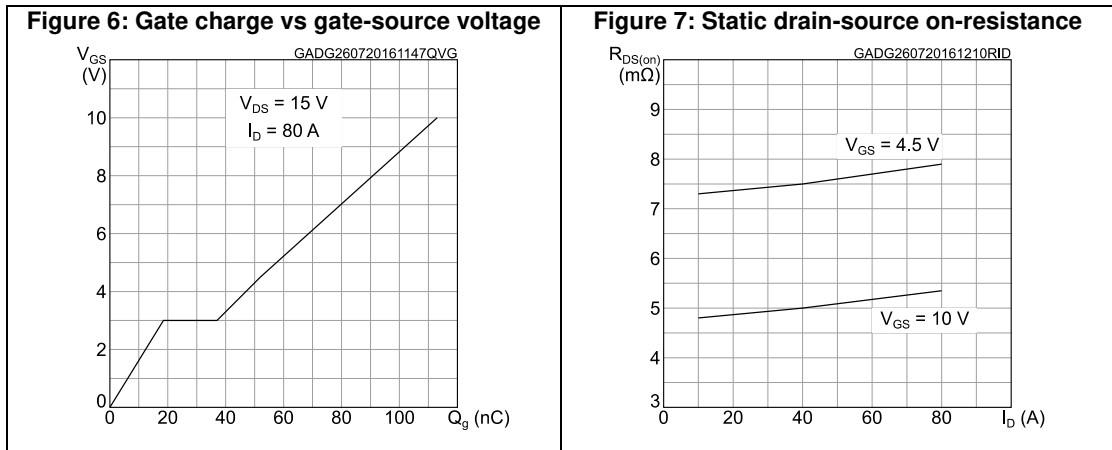
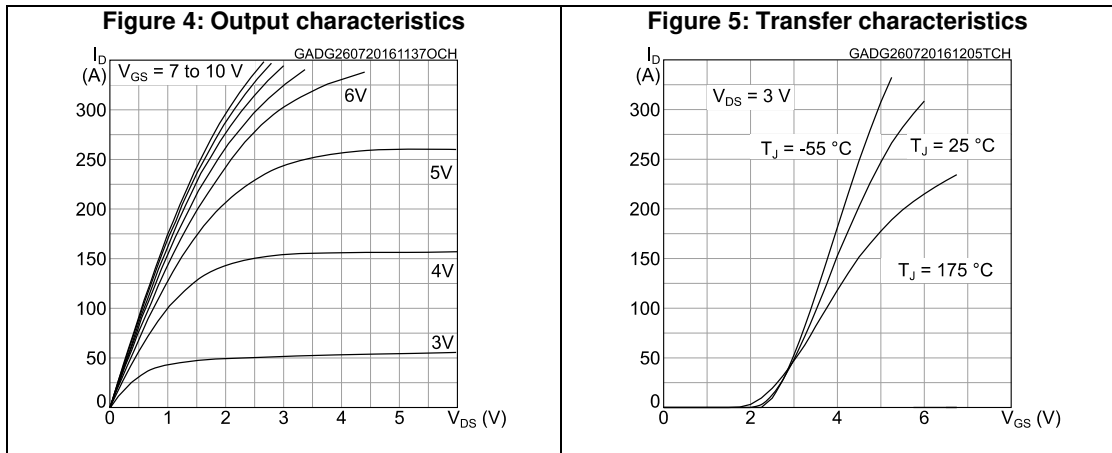
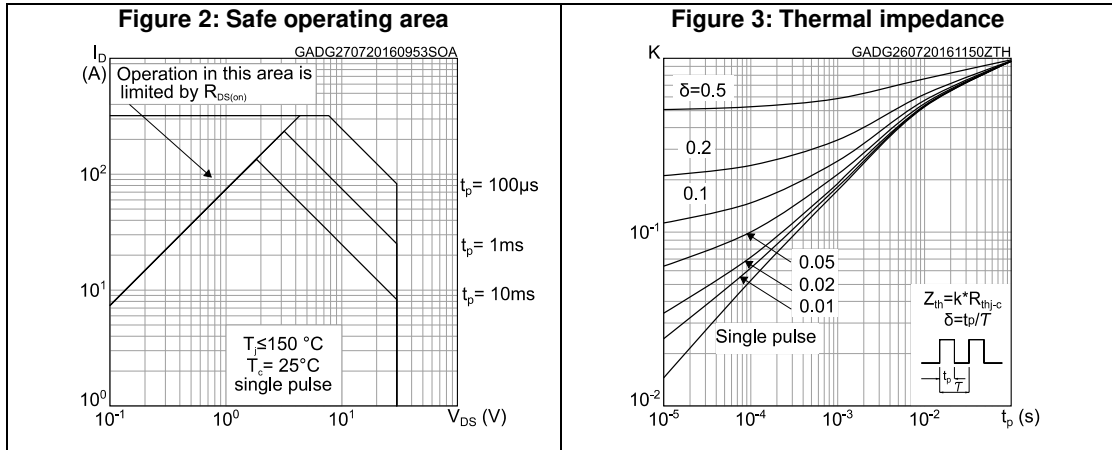

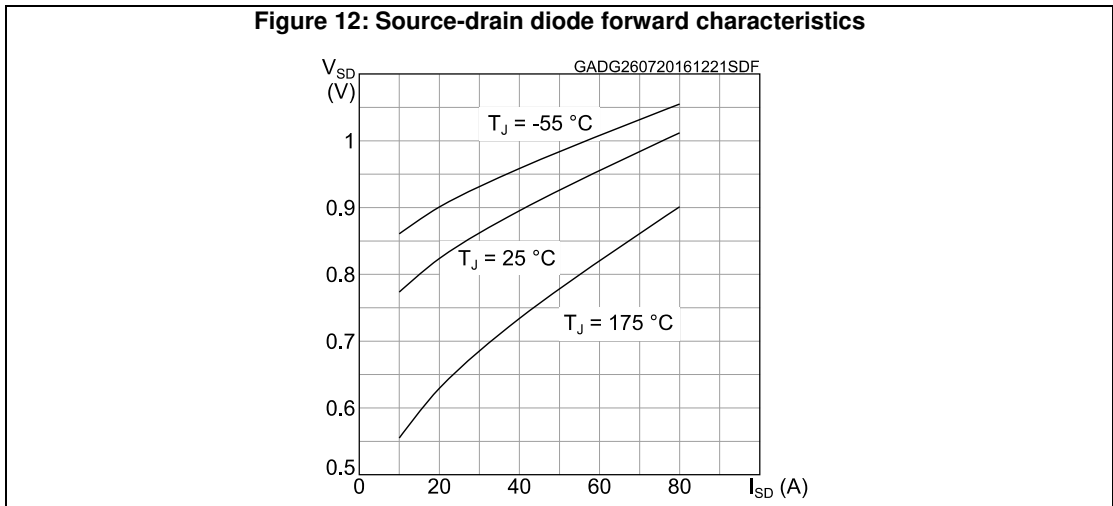
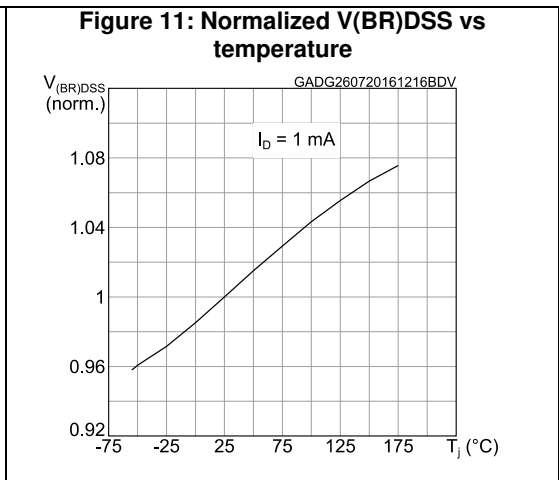
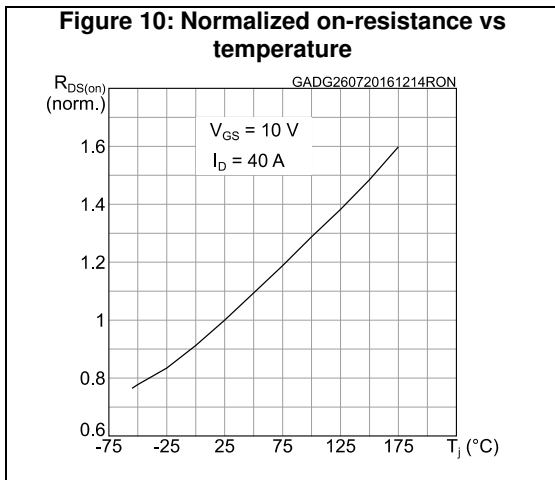
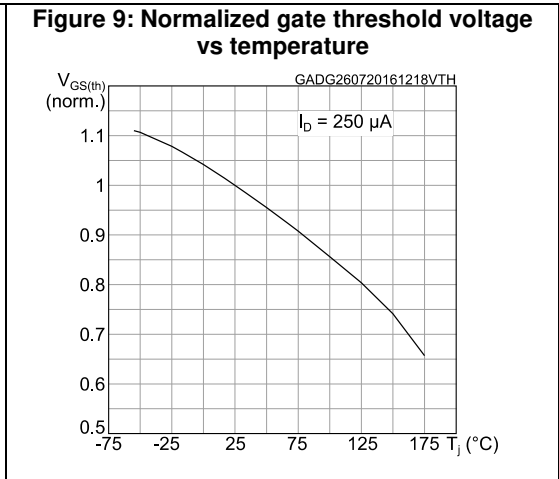
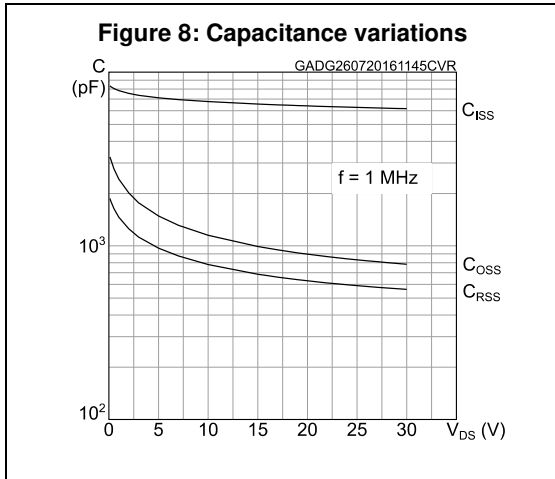

For the P-channel Power MOSFET, current and voltage polarities are reversed.

3 Test circuits

Figure 13: Switching times test circuit for resistive load

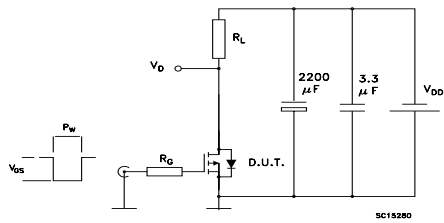

Figure 14: Gate charge test circuit

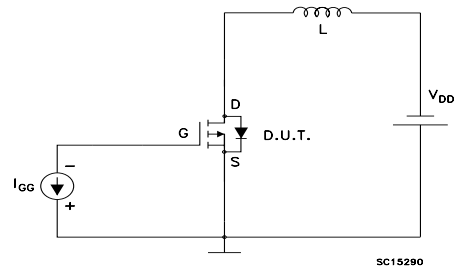
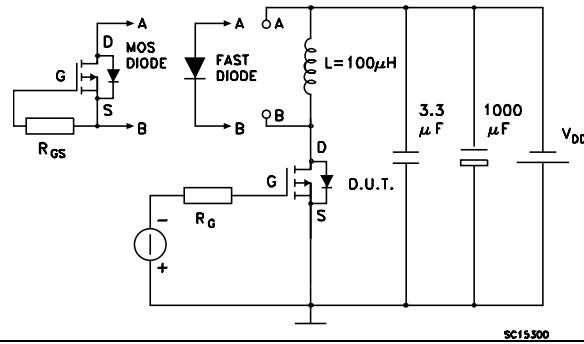

Figure 15: Test circuit for inductive load switching and diode recovery times



4 Package information

In order to meet environmental requirements, ST offers these devices in different grades of ECOPACK® packages, depending on their level of environmental compliance. ECOPACK® specifications, grade definitions and product status are available at: www.st.com. ECOPACK® is an ST trademark.

4.1 DPAK type A2 package information

Figure 16: DPAK (TO-252) type A2 package outline

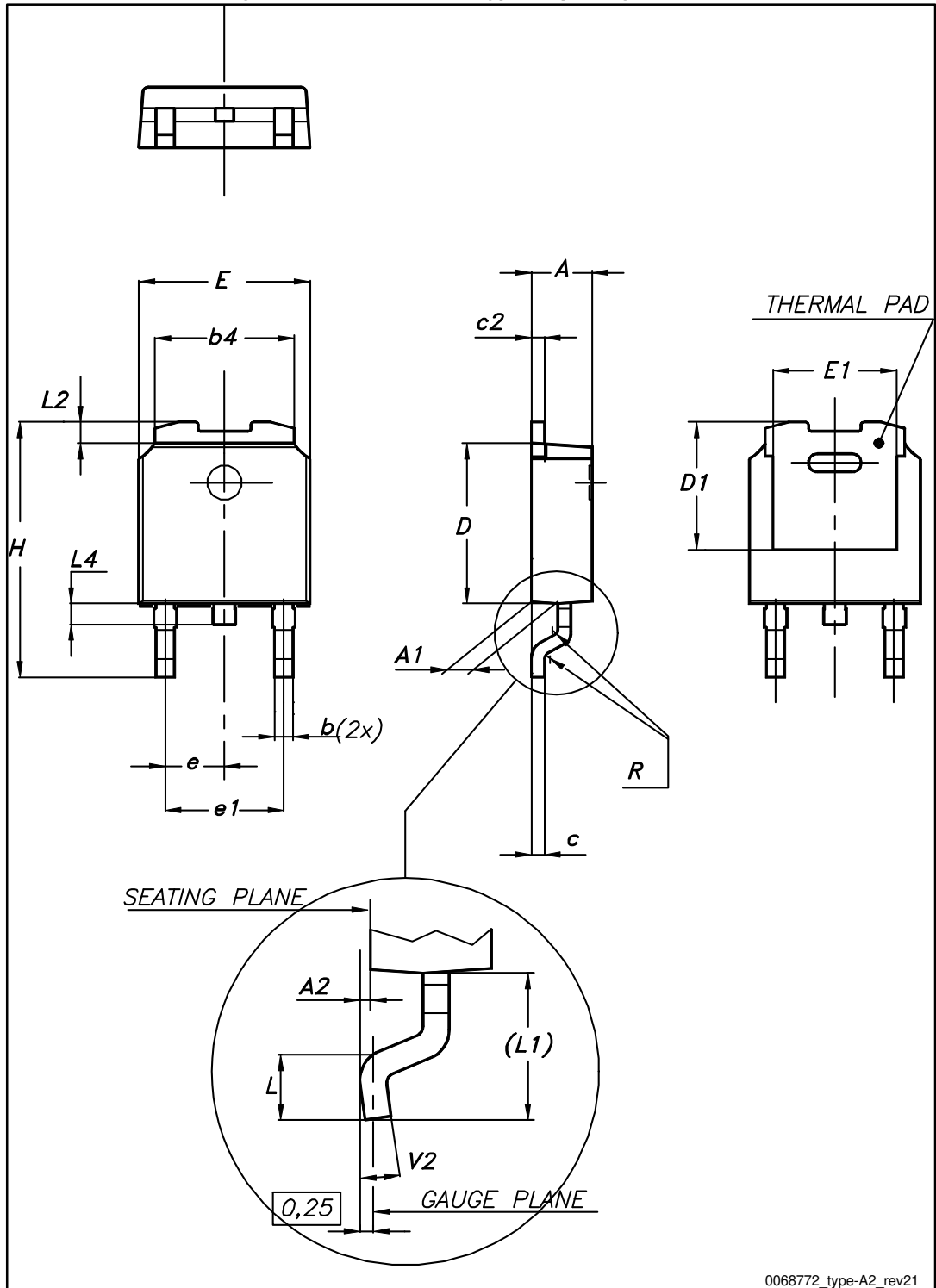
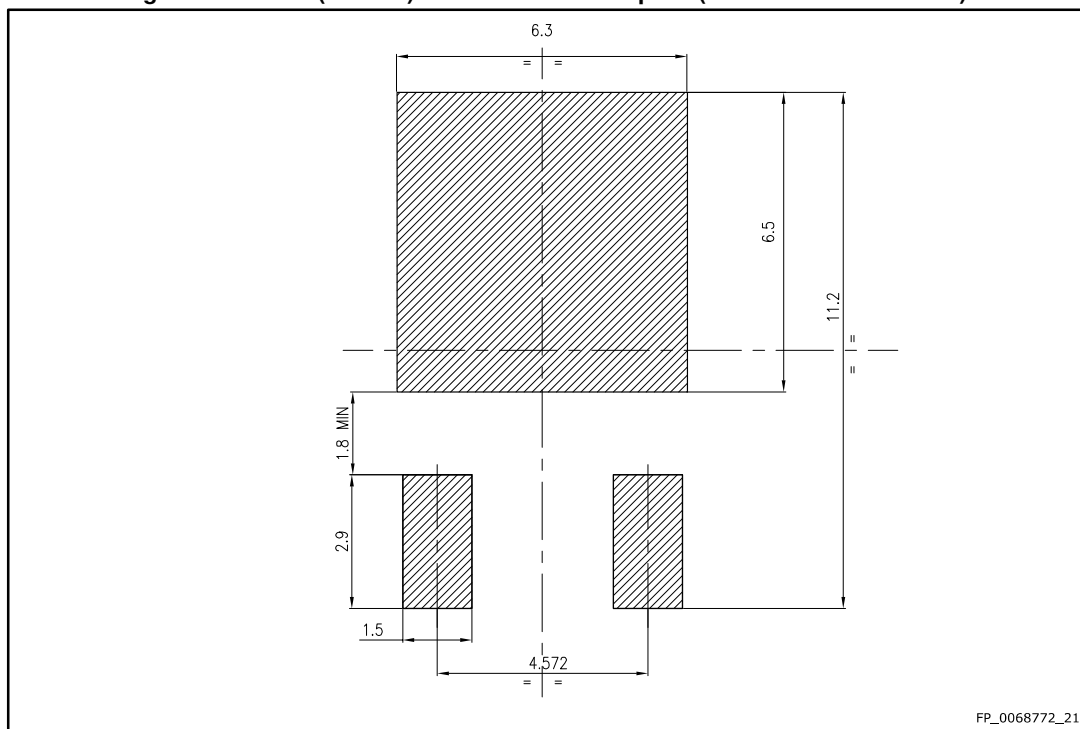

Table 8: DPAK (TO-252) type A2 mechanical data

Dim.	mm		
	Min.	Typ.	Max.
A	2.20		2.40
A1	0.90		1.10
A2	0.03		0.23
b	0.64		0.90
b4	5.20		5.40
c	0.45		0.60
c2	0.48		0.60
D	6.00		6.20
D1	4.95	5.10	5.25
E	6.40		6.60
E1	5.10	5.20	5.30
e	2.16	2.28	2.40
e1	4.40		4.60
H	9.35		10.10
L	1.00		1.50
L1	2.60	2.80	3.00
L2	0.65	0.80	0.95
L4	0.60		1.00
R		0.20	
V2	0°		8°

Figure 17: DPAK (TO-252) recommended footprint (dimensions are in mm)



4.2 DPAK packing information

Figure 18: DPAK (TO-252) tape outline

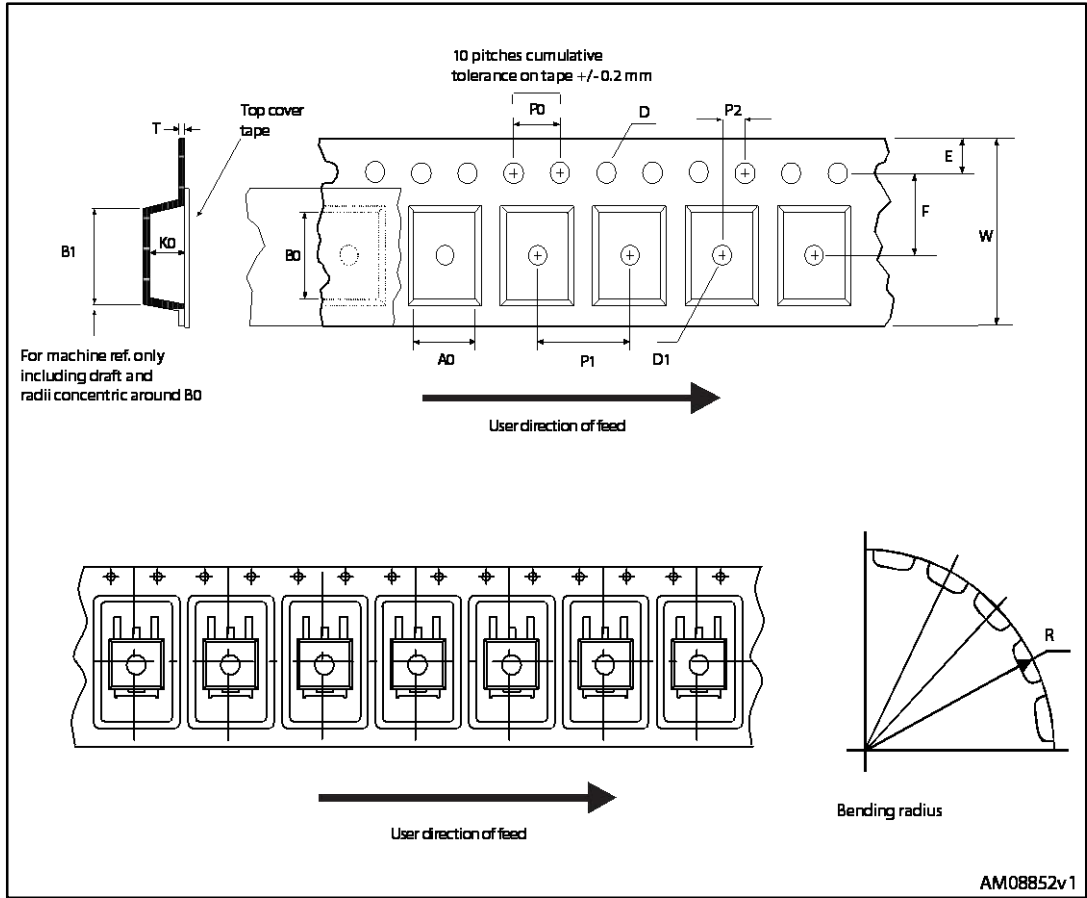

Figure 19: DPAK (TO-252) reel outline

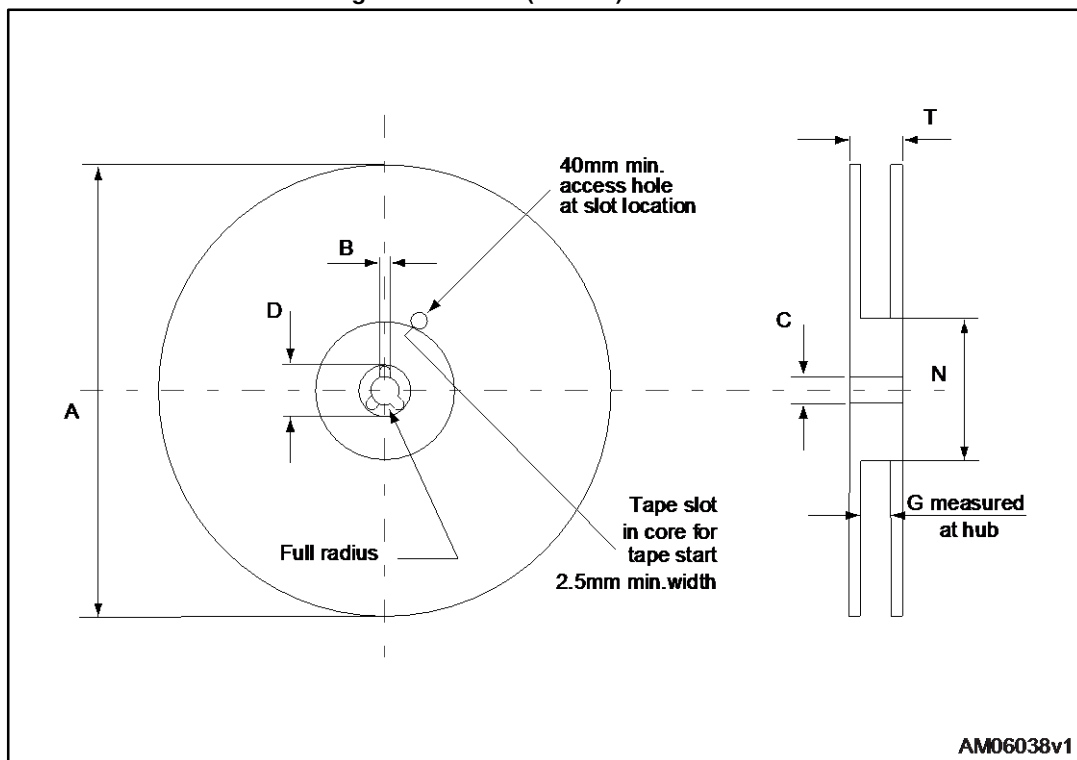

Table 9: DPAK (TO-252) tape and reel mechanical data

Tape			Reel		
Dim.	mm		Dim.	mm	
	Min.	Max.		Min.	Max.
A0	6.8	7	A		330
B0	10.4	10.6	B	1.5	
B1		12.1	C	12.8	13.2
D	1.5	1.6	D	20.2	
D1	1.5		G	16.4	18.4
E	1.65	1.85	N	50	
F	7.4	7.6	T		22.4
K0	2.55	2.75			
P0	3.9	4.1	Base qty.		2500
P1	7.9	8.1	Bulk qty.		2500
P2	1.9	2.1			
R	40				
T	0.25	0.35			
W	15.7	16.3			

5 Revision history

Table 10: Document revision history

Date	Revision	Changes
26-Jul-2016	1	First release.

IMPORTANT NOTICE – PLEASE READ CAREFULLY

STMicroelectronics NV and its subsidiaries ("ST") reserve the right to make changes, corrections, enhancements, modifications, and improvements to ST products and/or to this document at any time without notice. Purchasers should obtain the latest relevant information on ST products before placing orders. ST products are sold pursuant to ST's terms and conditions of sale in place at the time of order acknowledgement.

Purchasers are solely responsible for the choice, selection, and use of ST products and ST assumes no liability for application assistance or the design of Purchasers' products.

No license, express or implied, to any intellectual property right is granted by ST herein.

Resale of ST products with provisions different from the information set forth herein shall void any warranty granted by ST for such product.

ST and the ST logo are trademarks of ST. All other product or service names are the property of their respective owners.

Information in this document supersedes and replaces information previously supplied in any prior versions of this document.

© 2016 STMicroelectronics – All rights reserved