

# TLE4966K Double Hall Shield2Go

Quick Start  
V1.0.0



# Introduction

The TLE4966K is an integrated circuit double Hall-effect sensor designed specifically for highly accurate applications. Precise magnetic switching points and high temperature stability are achieved by active compensation circuits and chopper techniques on chip. They provide a speed signal at Q2 for every magnetic pole pair and a direction information at Q1, which is provided before the speed signal.

Key features are a 2.7V to 24V supply voltage operation, high sensitivity and stability of the magnetic switching points, high resistance to mechanical stress by Active Error Compensation and a reverse battery protection, superior temperature stability, peak temperatures up to 195°C without damage and an excellent matching between the 2 Hall probes.



Link to [Datasheet](#) and [Product Page](#)

# Evaluation Board Notes

## Information

- Supply voltage is typ. 3.3 V, please refer to [TLE4966K datasheet](#) for more details about maximum ratings
- Pin out on top (head) is directly connected to the pins of the TLE4966K
- If head is broken off, only two capacitors are connected to the TLE4966K
- Software compatible with Arduino and library fully integrated into the Arduino IDE
- Sales Name S2GO S2GO\_2\_HALL\_TLE4966K

Breakable Head



Link to [Board Page](#)

# Evaluation Board PCB Details

The

## TLE4966K Double Hall Shield2Go



**i** Ground pins on board connected with each other.

### Legend

	Information
	Labelling of Pins in Datasheet
	Pin Number in Datasheet
	Physical Pin Number
	Warning
	Additional Information
	Not Connected

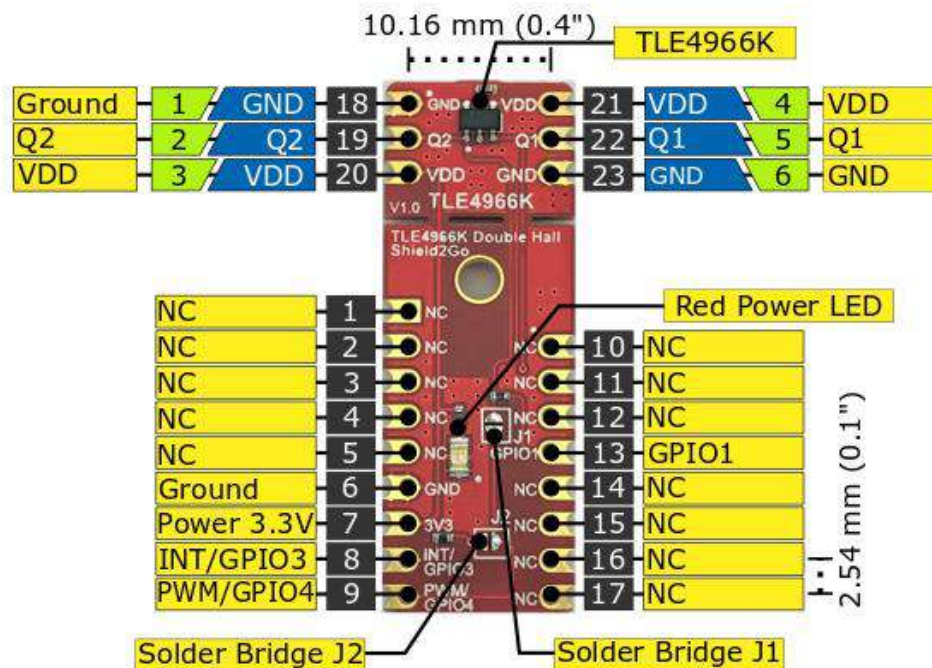

V1.0.0

**i** Solder Bridge J1 connects Q1 signal to PWM/GPIO4

**i** Solder Bridge J2 connects Q2 signal to PWM/GPIO4

[www.infineon.com](http://www.infineon.com)

# Evaluation Board Schematic

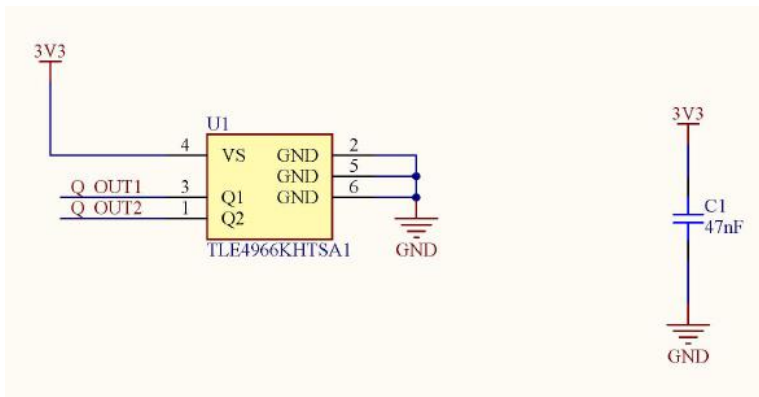

- **J1 Jumper** - If soldered, connects Q1 signal to PWM1/GPIO4 pin.
- **J2 Jumper** - If soldered, connects Q2 signal to PWM1/GPIO4 pin

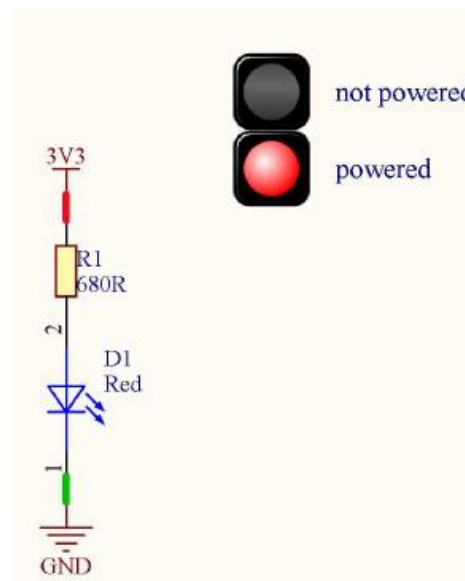
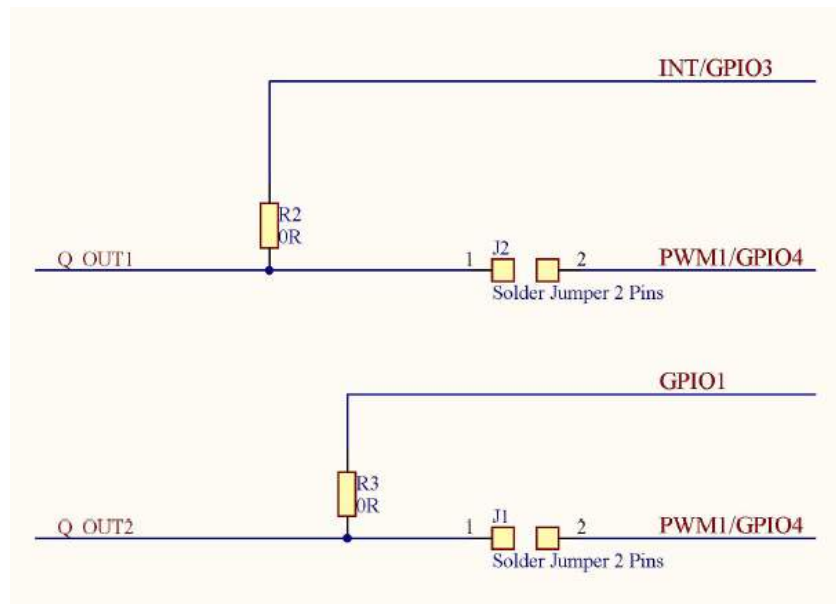

# Arduino: The Arduino IDE

## Arduino IDE



Arduino is a hardware-software prototyping environment IDE developed by [arduino.cc](http://arduino.cc):

- Installation Details for Windows:  
Click [here](#)
- Installation Details for Linux:  
Click [here](#)
- Installation Details for Mac OS:  
Click [here](#)
- Installation Details for Portable IDE:  
Click [here](#)

## Arduino Quick Start

- What is Arduino? Click [here](#)
- Extended information about the Arduino environment. Click [here](#)
- How to import libraries? Click [here](#)
- How to install additional boards? Click [here](#)
- Problems related to Arduino? Click [here](#) for troubleshooting

# How to download the library for Arduino - 1

## Notes

- Open the Arduino IDE
- Navigate to *Sketch – Include Library – Manage Libraries*
- The Arduino library manager will be opened (see next slide for further instructions)
- Additional notes for installation can be found in the GitHub repository, e.g. if the library manager is not used

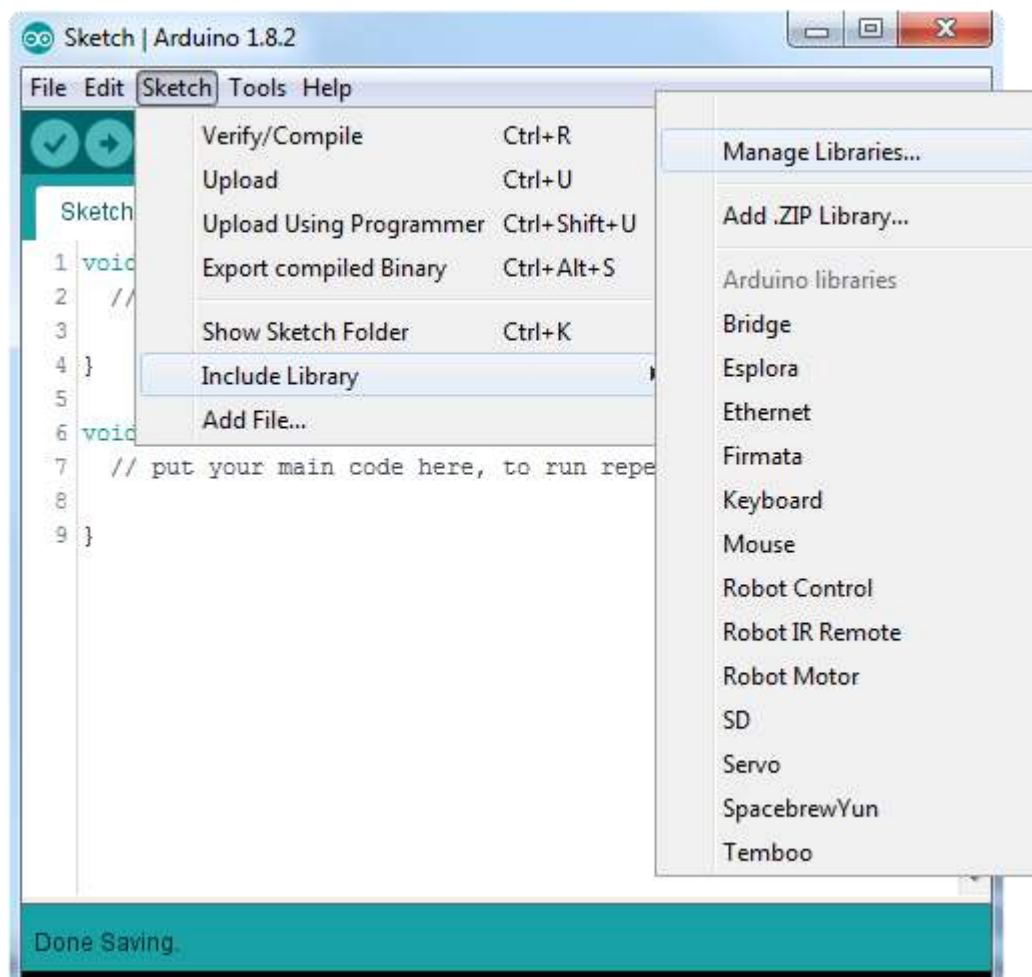

<https://github.com/Infineon/TLx4966-Direction-Speed-Sensor>



# How to download the library for Arduino - 2



## Notes

- The Arduino library manager is a comprehensive tool to install external libraries for Arduino
- Search for *TLx4966-Direction-Speed-Sensor* in the *Filter your search...* field
- Select as *Type: All* and *Topic: All* when searching for *TLx4966-Direction-Speed-Sensor*
- As shown in the picture, please choose the respective library and install it
- Regularly check your installed libraries for updates
- In case of problems, please visit also our [GitHub repository](https://github.com/Infineon/TLx4966-Direction-Speed-Sensor) and open an issue to get further help



<https://github.com/Infineon/TLx4966-Direction-Speed-Sensor>



# Example with XMC™ 2Go

## Notes

- The Shield2Go form factor of the Shield2Go evaluation board is directly compatible with the [XMC™ 2Go](#) board
- Stack the TLE4966K Double Hall Shield2Go board on top of the XMC™ 2Go as shown in the picture
- The additional pin on the left-top side (designated with NC) is left floating
- Using the [XMC-for-Arduino](#) Arduino integration, the [Arduino library](#) for the TLx4966 can be directly used
- Use the [Out of Shaft 3D Add-On](#) to test the examples



## Steps

- Open one of the examples for the TLx4966 from *File – Examples* and select as board *XMC1100 XMC2Go*
- Connect the stacked boards to the PC and press the *Upload* button
- Select the related COM port from *Tools – Port* and open the serial monitor with the set baud rate (see sketch/code with `Serial.begin(<BAUDRATE>);`);



<https://github.com/Infineon/XMC-for-Arduino>  
<https://github.com/Infineon/TLx4966-Direction-Speed-Sensor>



Part of your life. Part of tomorrow.

