

DWG. NO. SD-35127-003
 SIMILAR ITEM
 PROJECT NO.
 B
 DO NOT SCALE DRAWING DIMENSION IN METRIC

8 7 6 5 4 3 2 1

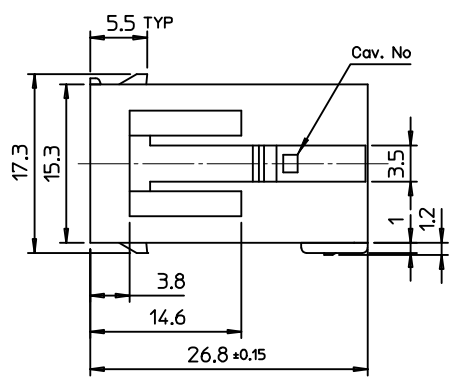
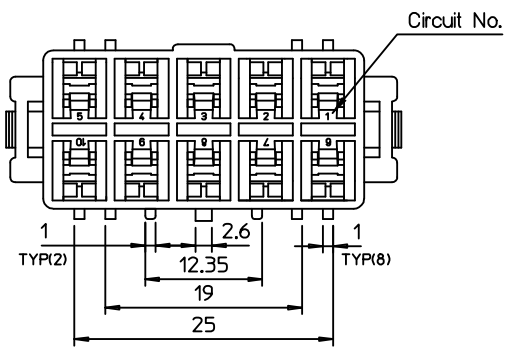

NOTES

1. MATERIALS: POLYESTER(PBT), UL94V-0, COLOR: NATURAL(WHITE)
2. DRAFT TO BE 0°30' UNLESS SPECIFIED.
3. WARPING TO BE 0.20 MAX.
4. PERMISSIBLE FLASH: 0.10MAX.
5. APPLICABLE MALE TERMINAL : 35040-****
6. MATED FEMALE HOUSING : 35128-****
7. PRODUCT SPECIFICATION : PS35127

351271000	35127-1000	10
MAT'L NO	ENG NO	CIRCUITS

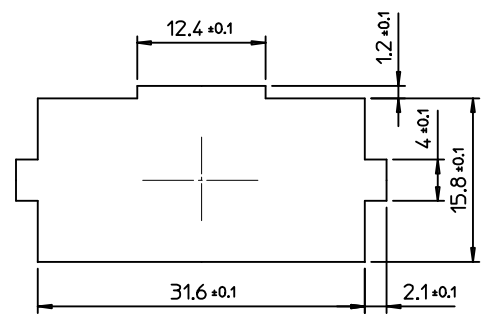
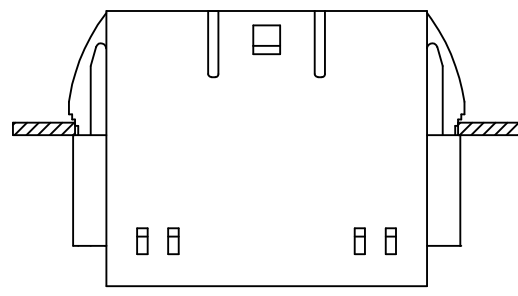
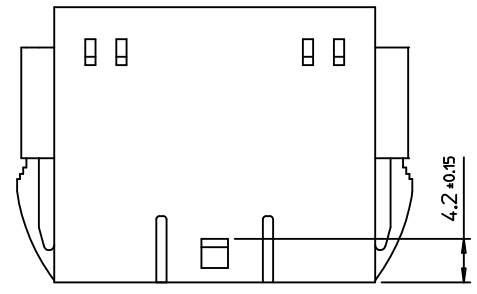

APPLICABLE PANNEL
THICKNESS : 1.2~2.0mm

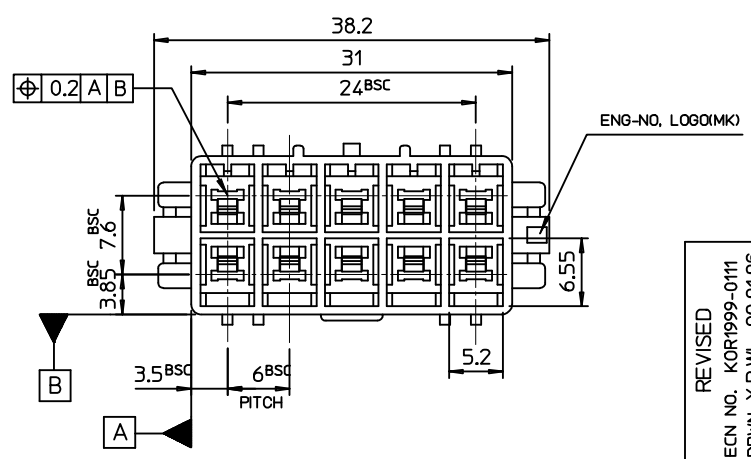

REVISED	ECN NO. KOR1999-0111 DRWN: Y.R.WI 00.01.06 CHK: J.K.OH APPR: C.W.LEE	DESCRIPTION	QUALITY SYMBOLS MAJOR CRITICAL	GENERAL TOLERANCES: (UNLESS SPECIFIED)		SCALE	DESIGN UNITS	THIRD ANGLE PROJECTION	DIMENSIONS:		SHT	REV
				m/m	INCH	2:1	<input checked="" type="checkbox"/> m/m <input type="checkbox"/> INCH	<input type="checkbox"/> m/m <input type="checkbox"/> INCH <input checked="" type="checkbox"/> m/m ONLY				
B				4 PLACES ±0.	±.	DRAWN BY & DATE Y.J.KIM 92.01.17		TITLE: 6.0 PITCH W-t-W MALE HSG - 10P				
				3 PLACES ±0.	±.	CHECKED BY & DATE Y.J.KIM 92.01.17		MOLEX INCORPORATED				
				2 PLACES ±0.	±.	APPROVED BY & DATE C.W.LEE 92.01.17		MATERIAL NO. SEE TABLE				
				1 PLACE ±0.2	±.	CAD FILENAME SD35127C_B.MI		DRAWING NO. SD-35127-003		SHEET NO. 1 of 1		
DRAFT WHERE APPLICABLE MUST REMAIN WITHIN DIMENSIONS				THIS DRAWING CONTAINS INFORMATION THAT IS PROPRIETARY TO MOLEX INCORPORATED AND SHOULD NOT BE USED WITHOUT WRITTEN PERMISSION.				KOREA		MX-A3		

8 7 6 5 4 3 2 1