

REVISIONS					
P	LTR	DESCRIPTION	DATE	DMN	APVD
AA		REVISED PER ECO-16-011265	12AUG2016	NK	MZ
AB		REV PER ECO-18-000441	23JAN2018	RS	MZ
AC		REVISED PER ECO-20-002045	13FEB2020	RK	MZ

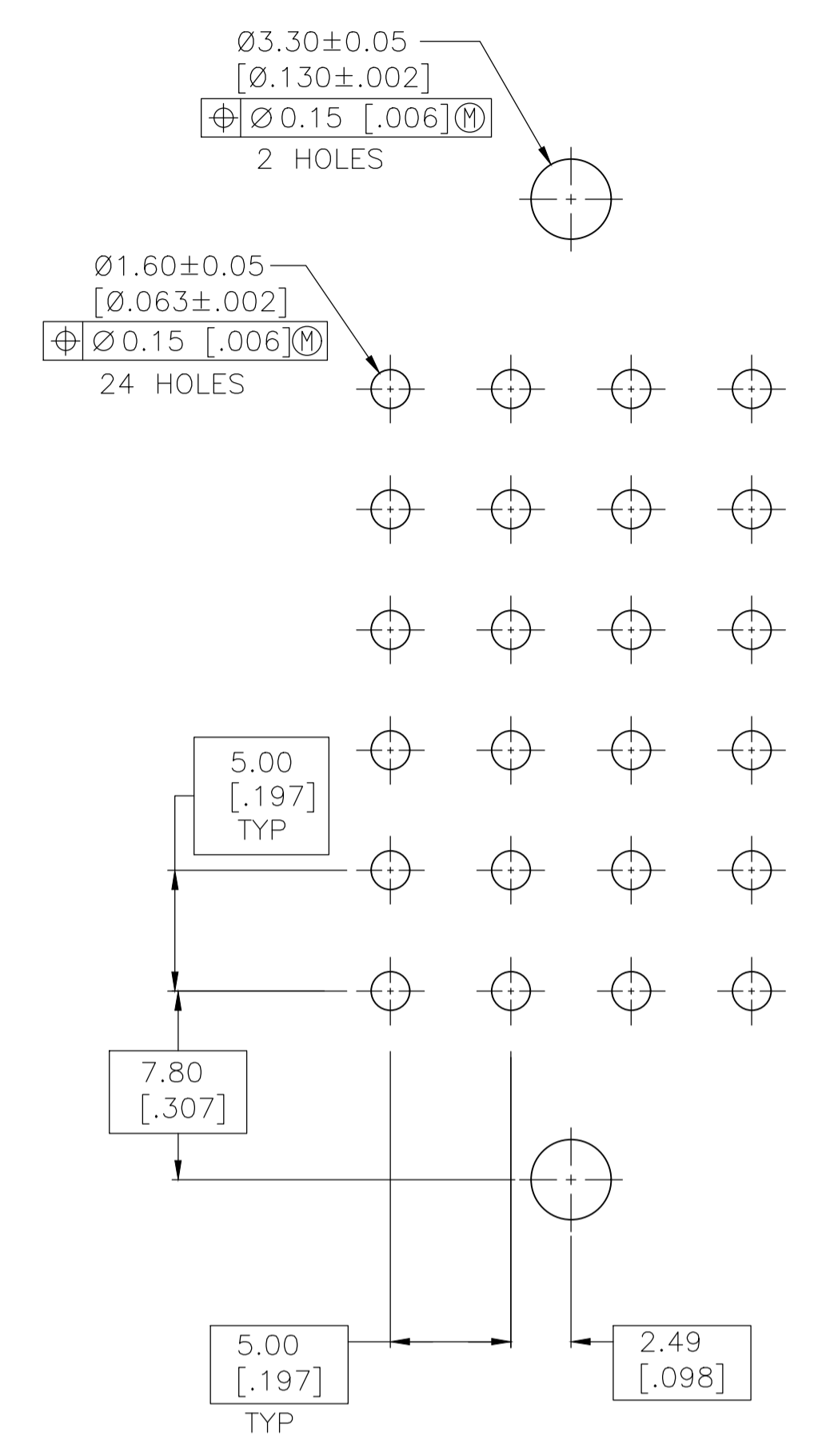

RECOMMENDED PC BOARD LAYOUT

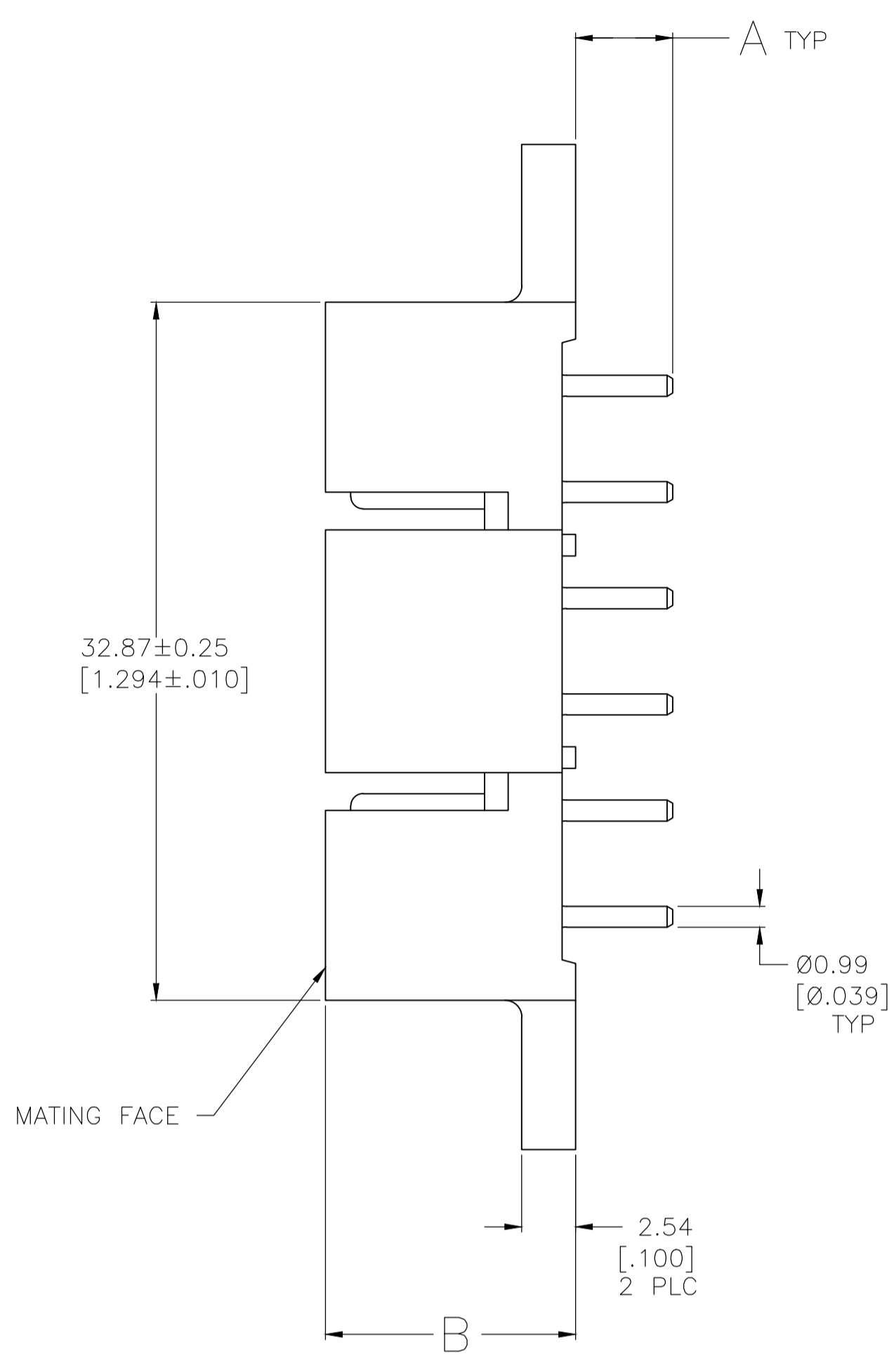
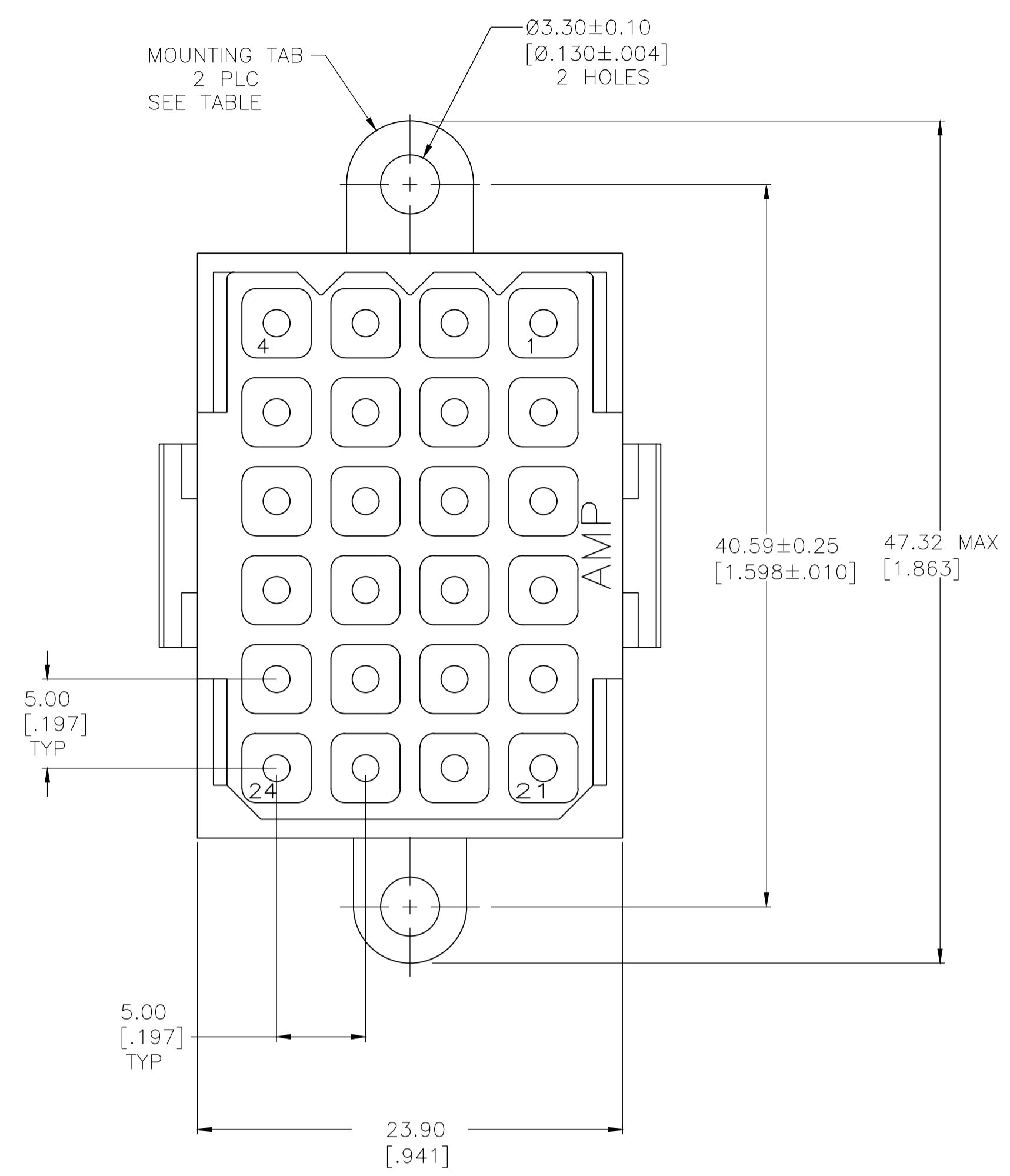
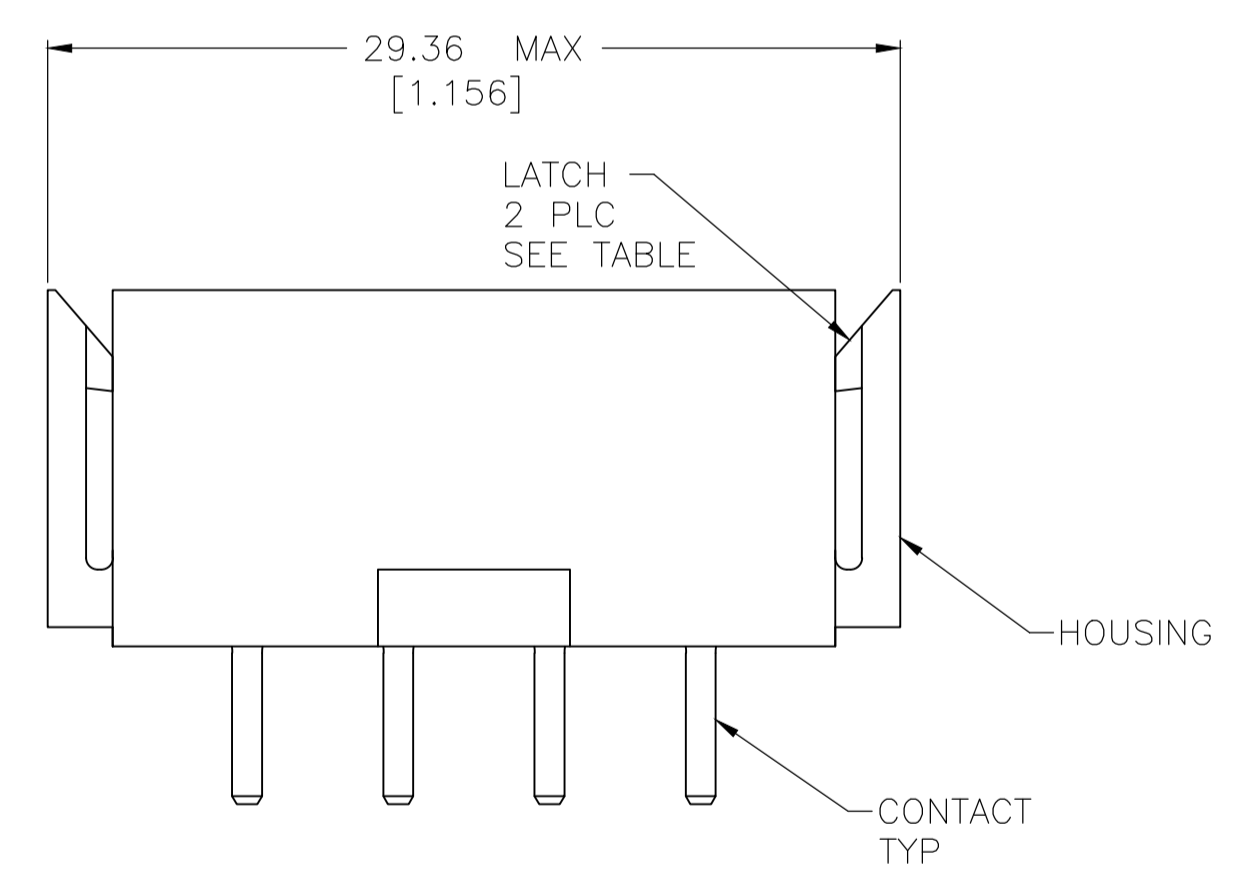

- 1 HOUSING MATERIAL: PA66, BLACK, UL 94 V-0 RATED
- 2 CONTACT MATERIAL: BRASS PER ASTM B36
- 3 3.81um [0.000150] MIN TIN-LEAD OVER 2.54um [0.000100] MIN COPPER OR 1.27um [0.000050] MIN NICKEL.
- 4 0.76um [0.000030] MIN GOLD FOR A LENGTH OF 5.08 [0.200] FROM MATING END, 3.81um [0.000150] MIN TIN-LEAD FOR A LENGTH OF 4.83 [0.190] MIN FROM OPPOSITE END, BOTH OVER 1.27um [0.000050] MIN NICKEL.
- 5 0.38um [0.000015] MIN GOLD FOR A LENGTH OF 5.08 [0.200] FROM MATING END, 3.81um [0.000150] MIN TIN-LEAD FOR A LENGTH OF 4.83 [0.190] MIN FROM OPPOSITE END, BOTH OVER 1.27um [0.000050] MIN NICKEL.
- 6 .000150 MIN TIN OVER .000100 MIN COPPER OR .000050 MIN NICKEL.
- 7 0.76um [0.000030] MIN GOLD FOR A LENGTH OF 5.08 [0.200] FROM MATING END, 3.81um [0.000150] MIN TIN FOR A LENGTH OF 4.83 [0.190] MIN FROM OPPOSITE END, BOTH OVER 1.27um [0.000050] MIN NICKEL.

	11.79[.464]	4.60±0.64[.181±.025]	YES	7	NO	1-206763-4
	11.79[.464]	4.60±0.64[.181±.025]	YES	7	YES	1-206763-3
	11.79[.464]	4.60±0.64[.181±.025]	YES	6	NO	1-206763-2
	11.79[.464]	4.60±0.64[.181±.025]	YES	6	YES	1-206763-1
OBSOLETE	11.79[.464]	4.60±0.64[.181±.025]	NO	5	YES	206763-9
OBSOLETE	13.31[.524]	4.60±0.64[.181±.025]	YES	3	NO	206763-8
OBSOLETE	11.79[.464]	4.60±0.64[.181±.025]	YES	4	NO	206763-4
OBSOLETE	11.79[.464]	4.60±0.64[.181±.025]	YES	4	YES	206763-3
OBSOLETE	11.79[.464]	4.60±0.64[.181±.025]	YES	3	NO	206763-2
OBSOLETE	11.79[.464]	4.60±0.64[.181±.025]	YES	3	YES	206763-1

THIS DRAWING IS A CONTROLLED DOCUMENT.

DIMENSIONS: mm [INCHES]	TOLERANCES UNLESS OTHERWISE SPECIFIED:	DIN L/SIDE 03/11/92	APVD R.STONE 3-17-92	NAME
0 PLC ± -	1 PLC ± -	2 PLC ± 0.13 [0.005]	3 PLC ± -	4 PLC ± -
CONTACT: SEE TABLE		TE Connectivity PIN HEADER ASSEMBLY, 24 POSITION, METRIMATE 108-10033		
MATERIAL	FINISH	WEIGHT	SIZE A1	SCALE 4:1
CUSTOMER DRAWING		REV 00779	C=206763	SHEET 1 OF 1