

# 350INV60-1 20-240-9G

6000 W DC-AC Inverter

The Bel Power Solutions 350INV60-120-240-9G is a highly efficient DC-AC inverter that converts high-voltage DC power into split phase AC power 120/240 VAC required to drive AC accessory loads directly from the High Voltage DC Drive or Battery Bus.

Liquid cooled DC-AC inverter operates at input voltages from 240 to 430 VDC and power range up to 6000 W. The DC-AC inverter utilizes CAN communication to the vehicle controller which allows selection of operational modes and frequency selection.

The DC-AC inverter is built in a sealed aluminum enclosure, ready to be mounted to the vehicle chassis and is a commercial-off the-shelf solution for electric vehicle manufacturers and developers.



## FEATURES

- 92 % typical efficiency
- Input voltage range: 240 – 430 VDC
- Power rating of 1 module 6 kW, possible parallel synchronized operation up to 6 modules with total power up to 32 or 36 kW
- Full galvanic insulation between input and output
- CAN bus serial interface
- Over temperature, output over voltage and over current protection
- Protection degree IP65 and IP67
- Liquid cooled
- Vibration immunity meets military level
- Three phase function: outputs of 3 modules can create 3 phase system 3 x 400 VAC or 3 x 208 VAC
- E-MARK E13\*10R00-10R05\*13865

## APPLICATIONS

- Hybrid and Electric Vehicles
- Medium through heavy duty, on and off highway vehicles

## 1. MODEL SELECTION

MODEL	DESCRIPTION
350INV60-120-240-9G	
350INV60-CON-KIT-8G	Kit that includes mating input connector with assembled 3 m of HV DC cable, output and signal connector with terminal pins
350INV60-CON-KIT-9G	Kit that includes input, output and signal connectors with terminal pins

## 2. INPUT SPECIFICATIONS

PARAMETER	DESCRIPTION / CONDITION	MIN	NOM	MAX	UNIT
Input Voltage		240	350	430	VDC
Max. Input Current	at nominal Power 6000 W, $V_{in} = 240 V_{mean}$		28	34	ADC
	at peak Power 8000 W $V_{in} = 240 V_{mean}$			37	ADC
Typical Efficiency	Maximum @ $V_{in} = 350 VDC$ , $P_{out} = 4 kW$ , $T_{coolant} = 40^{\circ}C$		92		%
Internal Power Loss	at $V_{in} = 350 VDC$ , $P_{out} = 6 kW$ , $T_{coolant} = 40^{\circ}C$		530		W
	at $V_{in} = 350 VDC$ , $P_{out} = 0 kW$ , $T_{coolant} = 40^{\circ}C$		110		W
Input Line Interruption	Inverter shutdown			240	VDC
Input Capacitance				54	$\mu F$
Insulation	Input-to-Chassis: Basic	3000			VDC
	Input-to-Output: Reinforced	3000			VDC
Insulation Resistance	Input to Chassis (ground)	10			$M\Omega$
	Input to Output	10			$M\Omega$
Input Current Waveform	Remaining amplitude part of 50 / 60 Hz component			10	%
Inrush Current	External pre-charging circuit required				

## 3. OUTPUT SPECIFICATIONS

PARAMETER	DESCRIPTION / CONDITION	MIN	NOM	MAX	UNIT
Output Voltage	L1 to N, L2 to N		120		VAC
	L1 to L2		240		VAC
Phase shift	L1 to L2		180		Deg
Output Current	at 6 kW		25		A
Output Power	Continuous			6	kVA
	Output overload, (max. 10 sec)			8	kVA
	Overload for motor load spin-up (max 3 sec)	8			
Static Regulation	L1 = L2 = 120 VAC at load 0 to 25 A	-12		+ 12	VAC
In-factory Output Calibration	L1 to L2 = 240 VAC at load 25 A, $T_{coolant} = 30^{\circ}C$	237.75		237.85	VAC
Frequency			50 / 60		Hz
Periodic & Random Deviation	at 120 VAC / Nominal load				
	- Differential Mode 20 MHz of $V_{o\_max}$ - Differential Mode 20 MHz		4 7		% Vp-p
Load Crest Factor	$V_{in} = 240 - 430 V_{mean}$ , $So1 = So2 = 3 kVA$ , $I_{pk1} = I_{pk2} = 70 A$ , $T_{ambient} = 85^{\circ}C$ , $T_{coolant} = 70^{\circ}C$			2.5	
Total Harmonic Distortion	$V_{in} = 240 - 430 V_{mean}$ , $So1 = So2 = (0.01 kVA, 1 kVA, 3 kVA)$ , $\cos(\phi) = (0.5, 1)$ , $T_{ambient} = 25^{\circ}C$ , $T_{coolant} = 50^{\circ}C$				
	0.1 – 1 kVA linear load 1 – 3 kVA linear load			4 10	%
Turn-On Delay	After application of DC input or cycling enable signal			5000	ms
Load Power Factor	The output voltage of the inverter kept within the limits.	0.3		1	

## 4. PROTECTION SPECIFICATIONS

PARAMETER	DESCRIPTION / CONDITION	MIN	NOM	MAX	UNIT
Output Over-Current Protection shut-down time	$V_{in} = 240 - 430 V_{mean}$ , $T_{ambient} = 85^{\circ}C$ , $T_{coolant} = 70^{\circ}C$ , $I_{o1} = I_{o2} = \text{step from 25 Arms to 27.5 Arms}$ $I_{o1} = I_{o2} = \text{step from 25 Arms to 33 Arms}$ $I_{o1} = I_{o2} = \text{step from 25 Arms to } >33 \text{ Arms}$			65 12 8	s
Short Circuit Survival shut-down time	$V_{in} = 350 V_{mean}$ , $T_{ambient} = 85^{\circ}C$ , $T_{coolant} = 70^{\circ}C$ , $I_{o1} = I_{o2} = \text{from 25 Arms}/\cos(\Phi) = 1 \text{ to short cut}$	60			ms
Output Over-Voltage Protection	Latch type	200		210	Vpk
Output Under-Voltage Protection	UV duration 60 ms	95		100	Vrms
Over-Temperature Protection	Converter shutdown at $T_{coolant}$ higher than	70			$^{\circ}C$
Input Fuse Protection	DC Input: Single on positive pole		50		A
Input Low Line Protection	Turn ON threshold	250	255	260	VDC
	Turn OFF threshold	235	240	245	
Input Overvoltage protection	Recovery: $V_{in}$ re-cycling or ENABLE	435		450	VDC

## 5. MONITORING AND CONTROL SIGNALS

PARAMETER	DESCRIPTION / CONDITION
CAN BUS SAE J1939 Interface	250 kBit/s
ENABLE	Inverter turned ON signal is pulled-up by 100 kOhm to 5 V internally by default (after $U_{in}$ is connected, unit will start with outputs enabled). Inverter turned OFF pulled down to 0.6 V or 100 Ohm to signal GND (pin 7) - by external components, e.g. switch.
FREQ_SELECT	Output frequency selected to 60 Hz signal is pulled up 100k Ohm to 5 V internally Output frequency selected to 50 Hz signal is pulled down to 0.6 V or 100 Ohm or less to signal GND (pin 7)
SYNC	Operation of multiple inverter modules in parallel mode. SYNC signals of individual modules have to be connected together and twisted with signal ground (pin 7)
HVIL function	Internal short is provided on HVIL pins.

## 6. READBACK ACCURACY ON CAN

PARAMETER	DESCRIPTION / CONDITION
Output current readback accuracy	Under all conditions for currents below 4.0 Arms read back is not working, i.e. read back value is not accurate / representing actual output current value. For current higher than 4.0 A this read back is valid: In case of crest factor 1 : $\pm 2.0$ Arms In case of crest factor higher than 2.5 : $\pm 3.0$ Arms
Input voltage readback accuracy	$\pm 4.0$ VDC
Output voltage readback accuracy	$\pm 2.0$ Vrms

## 7. ENVIRONMENTAL SPECIFICATIONS

PARAMETER	DESCRIPTION / CONDITION	MIN	NOM	MAX	UNIT
Altitude	Operating: 62 kPa absolute pressure Non-Operating: 18.6 kPa absolute pressure			3600 12200	m
Operating Temperature	Liquid cooled: $T_{coolant}$ with no derating	-40		+70	$^{\circ}C$
	$T_{amb}$ at full load, with no power derating	-40		+85	
Storage Temperature		-40		+95	$^{\circ}C$
Humidity	SAE J1455 JAN 2011				
Shock	SAE J1455				
Vibration	SAE J1455, MIL-STD-202G				



## 8. SAFETY, REGULATORY & EMI SPECIFICATIONS

PARAMETER	DESCRIPTION / CONDITION	CRITERION
Insulation	Basic Reinforced	Input-to-Protective Earth Input-to-Output
Radiated Emission	CISPR32, EN 55032	Class A
Electrostatic Discharge	IEC 61000-4-2, Contact discharge 8 kV, Air discharge 5 - 15 kV	Performance Criterion B
Radiated Electromagnetic Field	IEC 61000-4-3, SAE J1113/21	Performance Criterion B
Electrical Fast Transient (EFT) /Burst	IEC 61000-4-4, ISO 7637-2; Level 2 ( $\pm 2$ kV, 2.5 kHz)	Performance Criterion B
RF Conducted Immunity	Level 3 (10 V, 0.15 - 80 MHz, AM 80%, 1 kHz)	Performance Criterion A
RF Disturbances Immunity	SAE J1113-41	Class A

## 9. INVERTER MODULE CONNECTORS

PARAMETER	DESCRIPTION / CONDITION	MANUFACTURER	MPN
Input Connector	High voltage connector with HVIL function	Delphi HV280	13737767
Output Connector	High voltage unshielded connector	Delphi	13879038
CAN BUS and Signal Interface	Panel mounted	Molex MX150	47725-1310

## 10. CONNECTORS FOR MATING WIRING HARNESS

PARAMETER	DESCRIPTION / CONDITION	MPN
DC Input Connector	Housing Delphi (1 pc)	13861584
	Female terminal (2 pcs)	13572764
	HVIL housing (1 pc), Female terminal (2 pcs)	13738743 13543114
	Sealing (1 pc)	13756257
AC Output Connector	Housing Delphi (1 pc)	13879046
	Power terminal (4 pcs), Signal terminal (2 pcs, not used for contact)	13783301 13711549
	CAN BUS and Signal Interface	Housing Molex (1 pc) Female terminal (12 pcs, 11 pcs used for contact)

**Note:** Not all cavities are used for electrical function in signal and output connector. In order to maintain IP67 also non used cavities in mating connector must be assembled by dummy wires to get gasket into tightness.

## 11. CONNECTOR PINOUTS

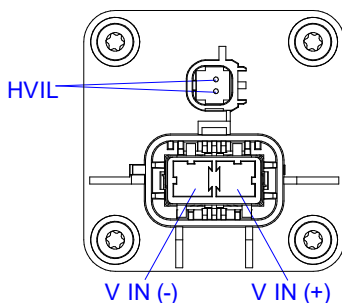

DC Input Connector

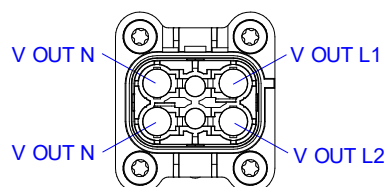

AC Output Connector

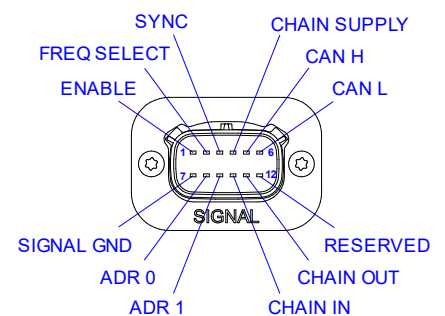

Signal Connector

PIN	DESCRIPTION	FUNCTION
1	ENABLE	ENABLE
2	FREQ_SELECT	Frequency select
3	SYNC	Multi inverter synchronization
4	CHAIN_SUPPLY	Chain protection supply
5	CAN_H	CAN BUS H
6	CAN_L	CAN BUS L
7	SIGNAL_GND	Signal return
8	ADR_0	Addressing pin
9	ADR_1	Addressing pin
10	CHAIN_IN	Chain protection input
11	CHAIN_OUT	Chain protection output
12	Reserved	Reserved

Signal Connector Pin Description

## 12. PARALLEL FUNCTION OF MULTIPLE MODULES IN SYNCHRONIZED MODE

Purpose of running multiple modules in parallel is to get higher power. The maximum number of parallel modules is 6, see wiring diagram below.

Number of modules	Max. Power 1 [kVA] Full coolant temp. range	Max. Power 2 [kVA] Reduced coolant temp. range to 50°C
2	11.2	12
3	16.8	18
4	22.4	24
5	28.0	30
6	33.6	36

During parallel operation load current is shared evenly between modules. However because of production tolerance on the output voltage calibration and passive current sharing between modules (droop sharing) there may be a deviation of load current - up to 6% difference module to module is possible vs. the average value. The result of this deviation may cause some modules to deliver more current than others. In the Table above, in the centre column (Max. power 1), is the available power when none of the paralleled modules override their nominal current of 25 A. The right column specifies condition for n modules -  $n * 6$  kVA. In the case of Max. Power 2, some of the modules may be operating over their nominal power. Functioning above the maximum power is however acceptable since the overcurrent protection only activates at an output current of ~27.5 A, however this is only possible when operating at a lower coolant temperature range, so that the over-temperature protection doesn't trip off the overloaded module.

## 13. THREE-PHASE FUNCTION

Modules connected in a 3 phase configuration, per the diagrams below are able to produce:

Case A: One load 3 x 400 VAC / 25 A

Case B: Two Loads 3 x 208 VAC / 25 A

The slaves function at 120° and 240° out of phase from the master by setting up the addressing per the table below:

ADR_0 (PIN 8)	ADR_1 (PIN 9)	FUNCTION
1	1	Master
0	1	Slave 120 Deg
1	0	Slave 240 Deg
0	0	Reserved

Note: Each of the address pins are digital and have internal pull up impedances, therefore a non-connected pin will result in a logic high.



## 14. ADDITIONAL DETAILS

### MULTI-UNIT CAN ADDRESSING

After input power is connected parallel modules (or units connected in a three phase configuration, here after called “paired” units) automatically allocate their addresses on the CAN line. The design allows up to 6 paired modules, addresses are always chosen from the range of B4 to B9. Every time the input power is re-cycled there may be different addresses allocated to units in comparison to the previous state, but they will be always inside of range of B4 to B9. If the user counts active devices, within this range, you know how many modules are actively connected. In case the CAN line is not required for paired modules, then it does not need to be connected. However in the case CAN is not used the sync BUS and chain circuit still need to be co connected.

### ENABLE CONTROL

Output enable control works either through the hardware enable pin or by sending CAN message “nv\_b\_cmd\_Enable”. Hardware ENABLE PIN has higher priority than CAN Enable command, i.e. if hardware ENABLE PIN is pulled down to 0.6 V or 100 Ohm to signal GND (pin 7), unit will ignore CAN Enable command until hardware ENABLE PIN is disconnected from 0.6 V / signal GND (pin 7). Hardware ENABLE PIN is internally pulled up by 100 kOhm to 5 V by default, which means, after Uin is connected, unit will start with outputs enabled. To start unit with output disabled ENABLE PIN has to be connected to 0.6 V or 100 Ohm to signal GND (pin 7), by external components, e.g. switch.

In parallel mode, hardware enable pins are required to be wired together, this ensures the same level is sent to all modules. The requirement CAN enable message is sent out to all active units. By re-cycling the enable control (disable then re-enable) will clear an output latch condition that might have occurred because of a protection feature e.g.: output over current, over temperature, etc.

### PAIRED MODE SYNC

Modules use the “sync” signal to synchronize their outputs. This happens automatically and there is no user intervention required. After start up one of the paired units automatically establishes itself as the master, all other units in the paired configuration will default to slave operation. Slaves synchronize their outputs according to the reference waveform from master.

### READ BACK OF INPUT / OUTPUT VALUES

In paired mode each module provides its own values. However in paired mode when input and/or output voltages are tied together there could be a read back inaccuracy of up to typical  $\pm 2V$ . Regarding output current, each module will provide its own value. To get the total output current the user must summarize read backs from all active modules.

### PAIRED MODE PROTECTION FUNCTIONS

In paired mode, the signal connector wiring is continuously monitored. This monitoring serves to protect modules against losing synchronization signal during service and is established via a chain circuit starting from the first module and ending with the last. The user needs to establish the chain circuit in the external wiring harness according to diagrams below. In case the chain line is broken all units in the chain will shut down and provide active warning bit on CAN Bit 29 – Inv\_b\_ft\_SyncError. This may happen for example when signal connector of any unit is unplugged during service.

There is no redundancy provided for paired modules. This means in case a functional failure would occur in any of the paired modules, all modules would shut down. This is a requirement to protect output stages of modules against permanent damage.

### PAIRED MODE CHASSIS GROUNDING

During parallel operation it is required that the chassis of all paired modules are galvanic tied together and grounded to PE.

15. WIRING SETUP

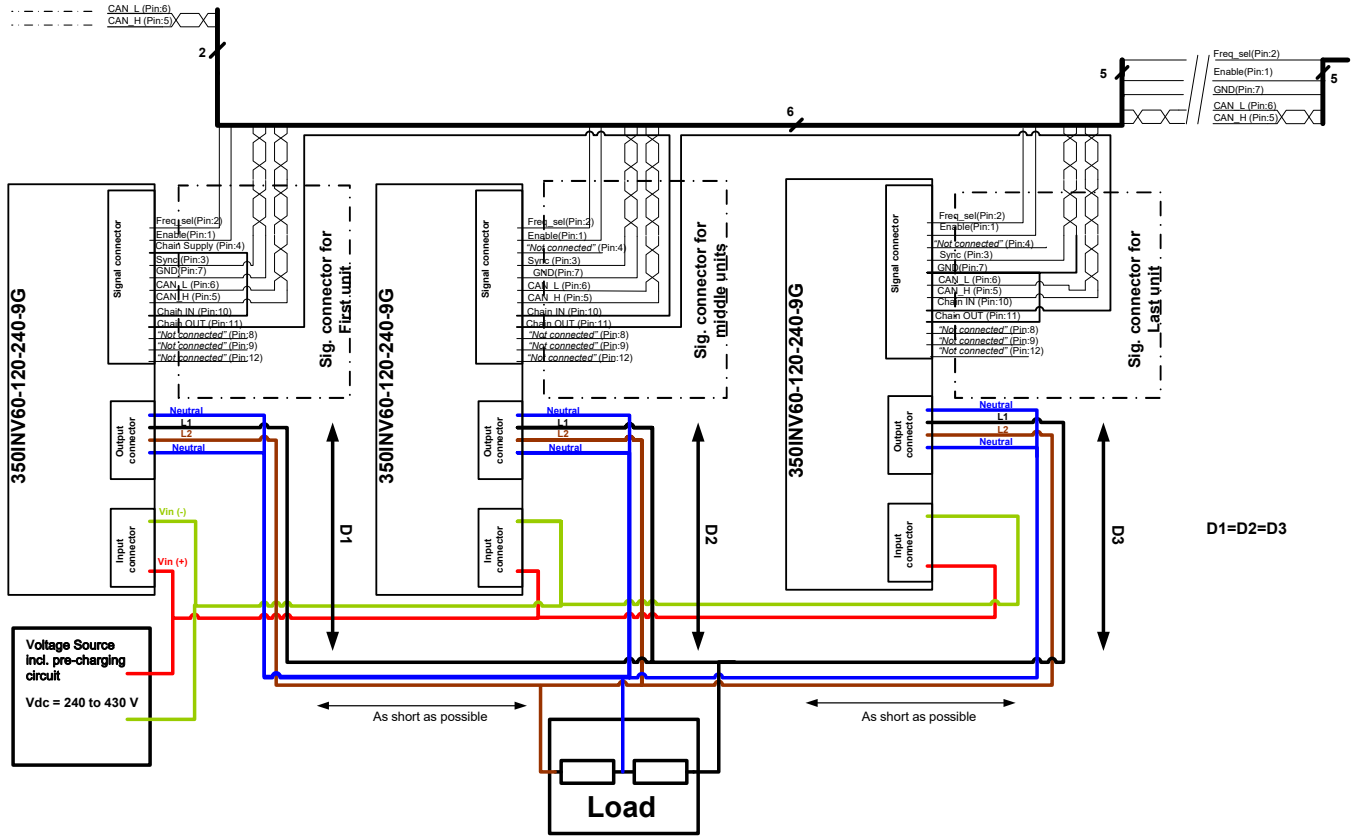

Figure 1. Wiring setup for parallel operation 350INV60-120-240-9G

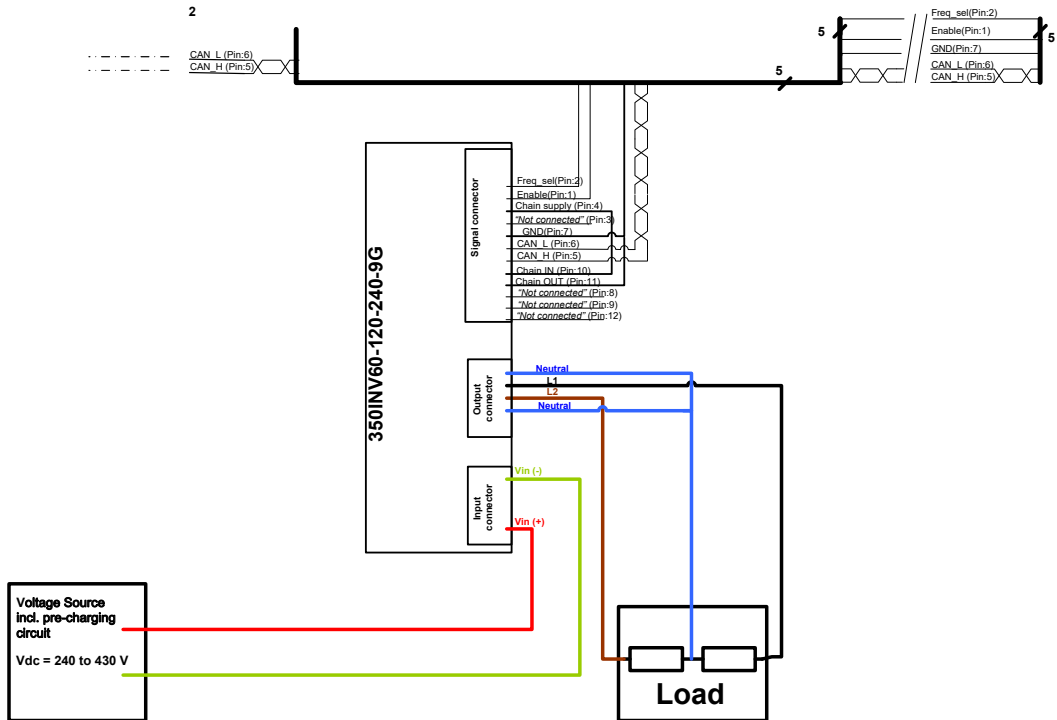

Figure 2. Wiring setup for single operation 350INV60-120-240-9G



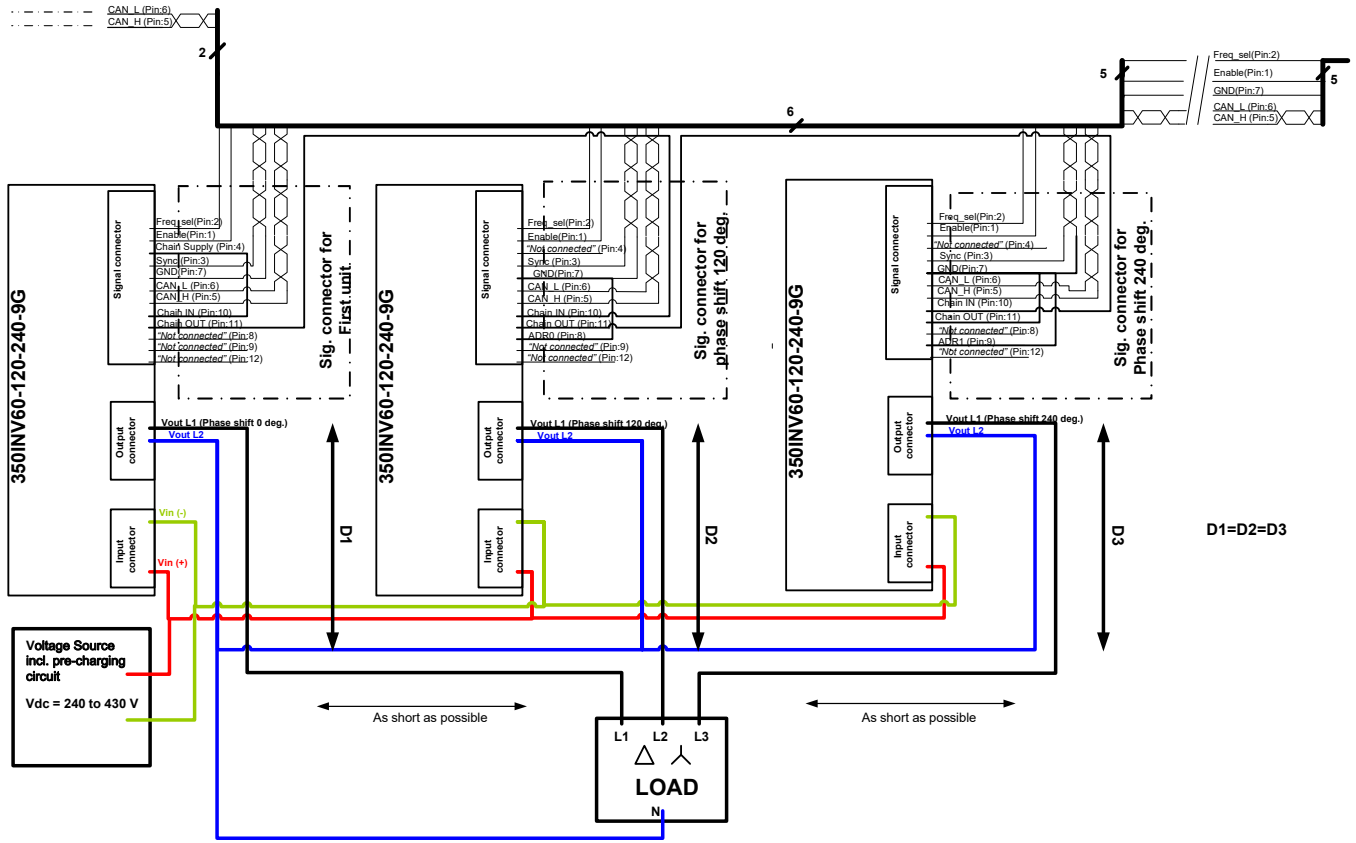

Figure 3a. Case A: Wiring setup for 3-phase operation One load 3 x 400 VAC / 25 A for 350 / 700INV60-120-240-9G

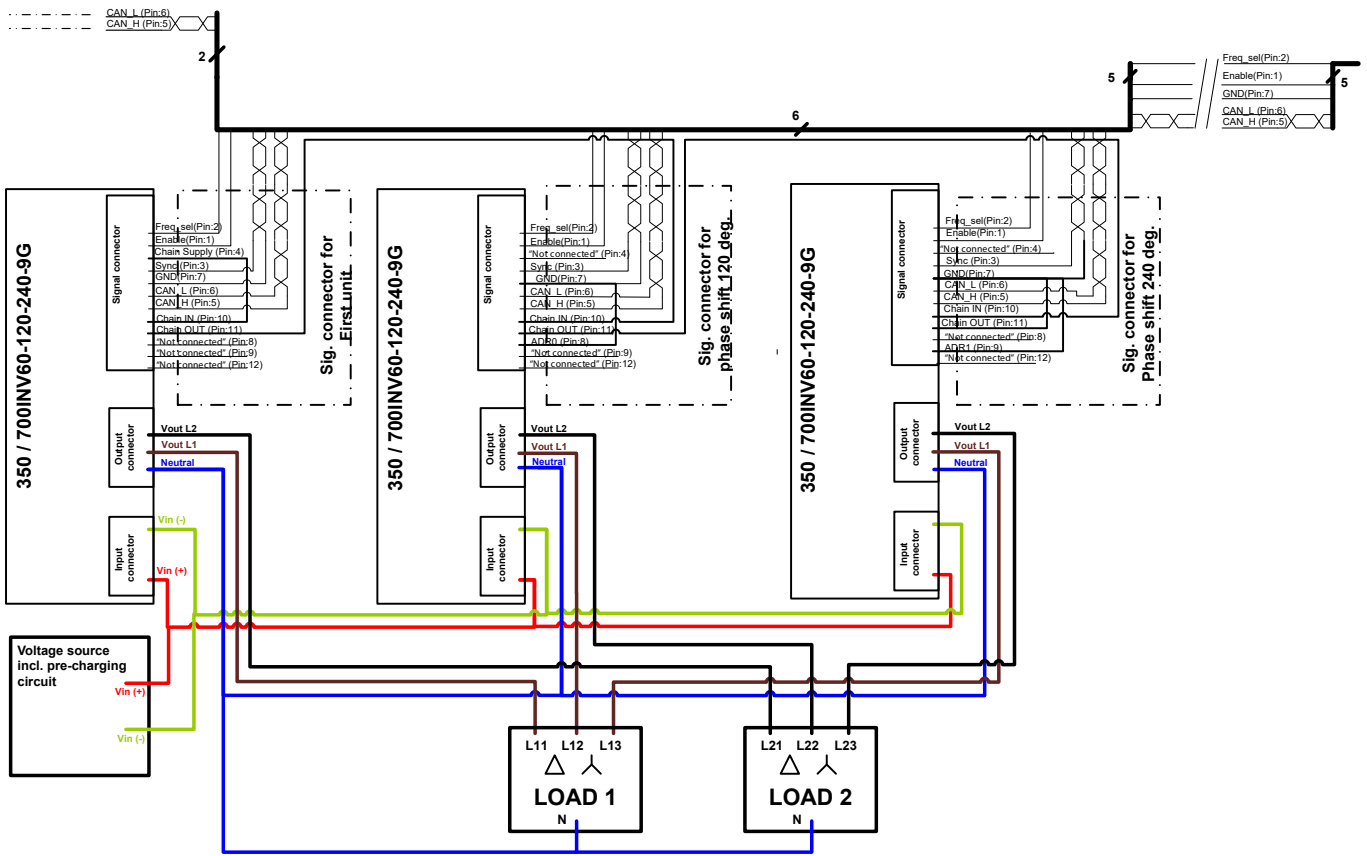

Figure 3b. Case B: Wiring setup for 3-phase operation Two Loads 3 x 208 VAC / 25 A for 350 / 700INV60-120-240-9G



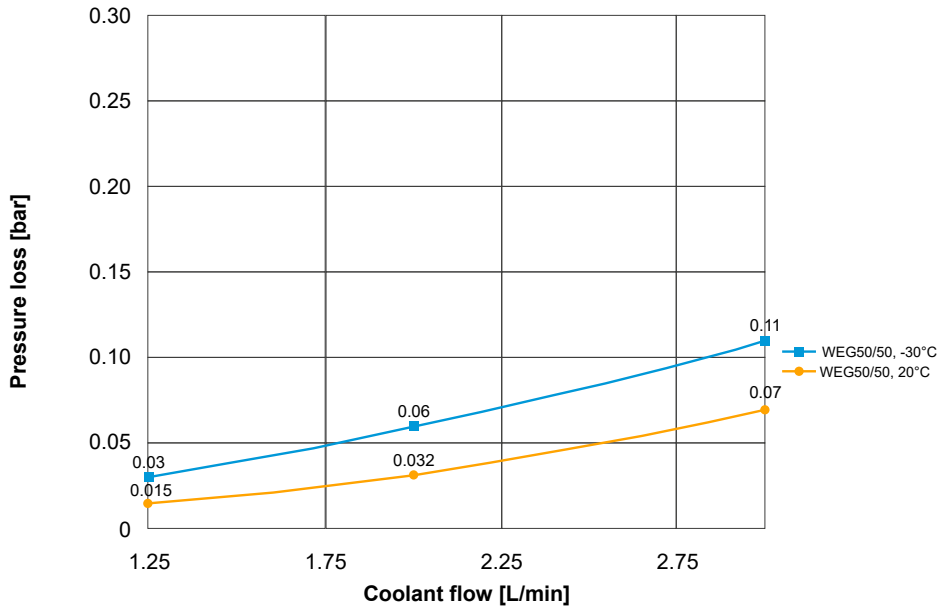

Figure 4. 350INV60-120-240-9G Pressure losses at coolant flow dependency

## 16. MECHANICAL SPECIFICATIONS

PARAMETER	DESCRIPTION / CONDITIONS	MIN	NOM	MAX	UNIT
Dimensions	W x H x D		374 x 163 x 384		mm
Weight			20		kg
Enclosure	IP65 and IP67				
Maximum allowed pressure of cooling liquid	20 PSI (1.4bar)				
Recommended Coolant Medium/Mixture	50/50 Propylene or Ethylene Glycol/Water				
Recommended Coolant Flow	0.0208 to 0.0505 L/s (0.33 to 0.8 GPM)				
Inlet/Outlet Coolant Connection	Hose Adapter, Threaded 1-14 UNF, Stainless Steel				



**MECHANICAL DRAWINGS**

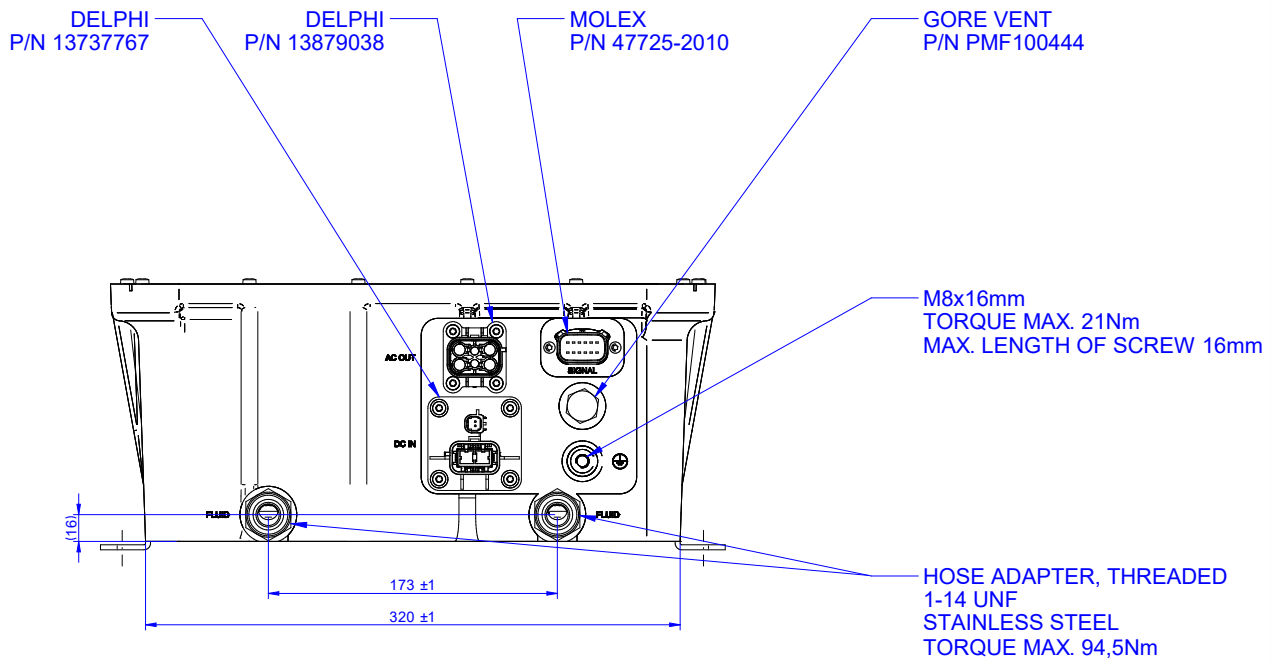

Figure 5. Front view

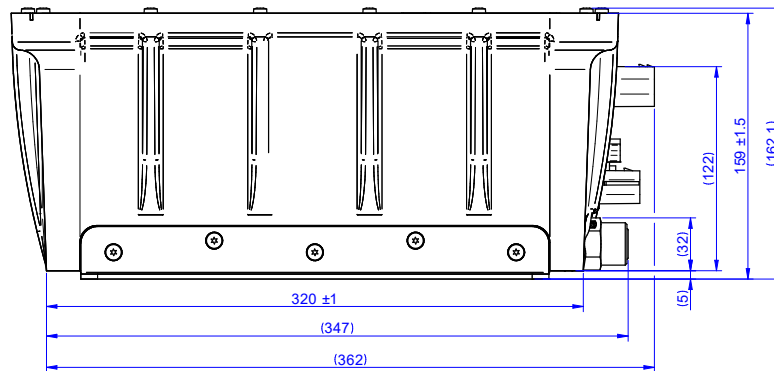

Figure 6. Side view

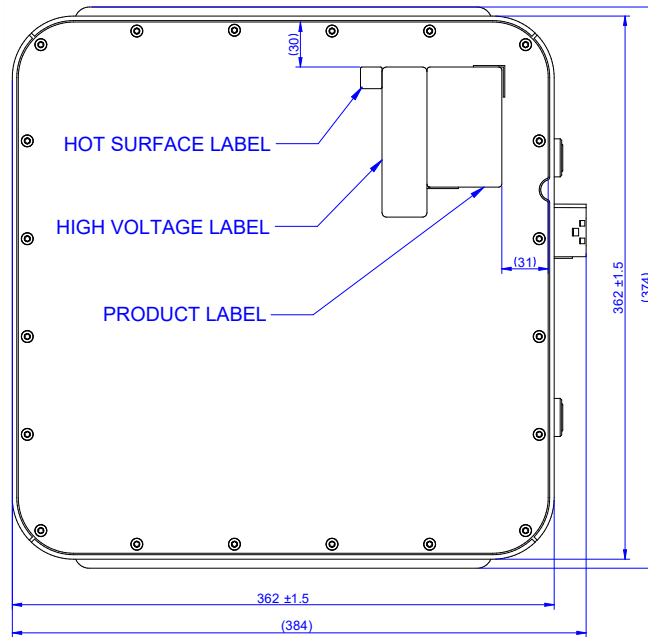

Figure 7. Top view

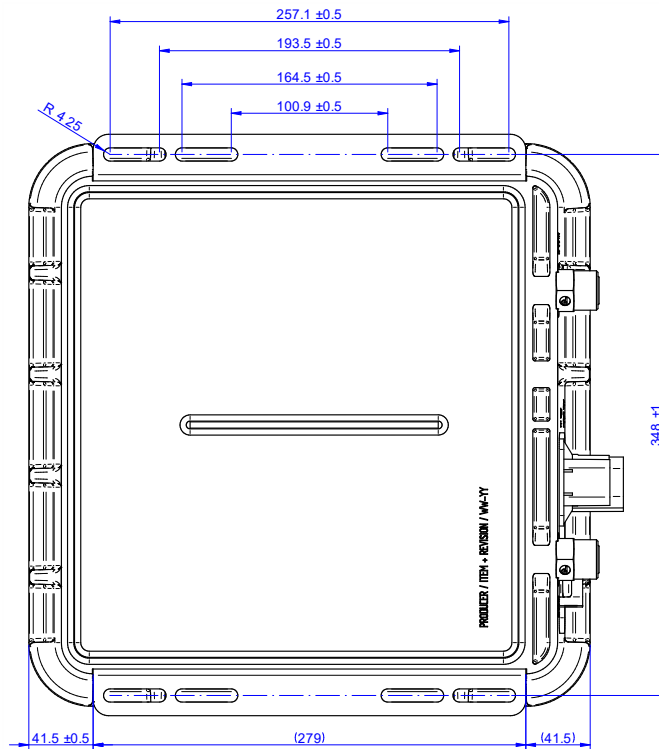

Figure 8. Bottom view

For more information on these products consult: [tech.support@psbel.com](mailto:tech.support@psbel.com)

**NUCLEAR AND MEDICAL APPLICATIONS** - Products are not designed or intended for use as critical components in life support systems, equipment used in hazardous environments, or nuclear control systems.

**TECHNICAL REVISIONS** - The appearance of products, including safety agency certifications pictured on labels, may change depending on the date manufactured. Specifications are subject to change without notice.

