

THIS DRAWING IS UNPUBLISHED. RELEASED FOR PUBLICATION
 © COPYRIGHT - By - ALL RIGHTS RESERVED.

LOC		DIST		REVISIONS			
P	LTR	DESCRIPTION	DATE	DWN	APVD		
	A	PRODUCTION RELEASE PER ECO-13-014747	9-18-13	CT	RL		

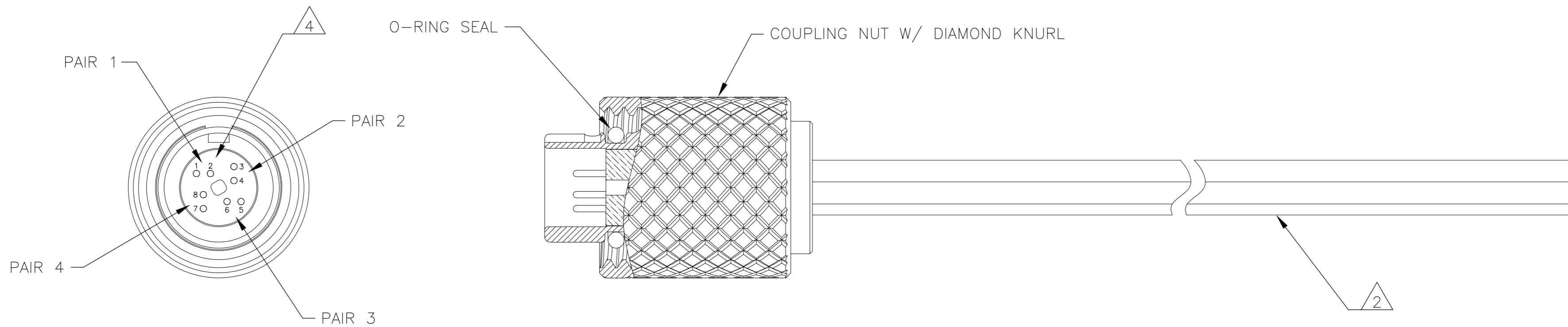
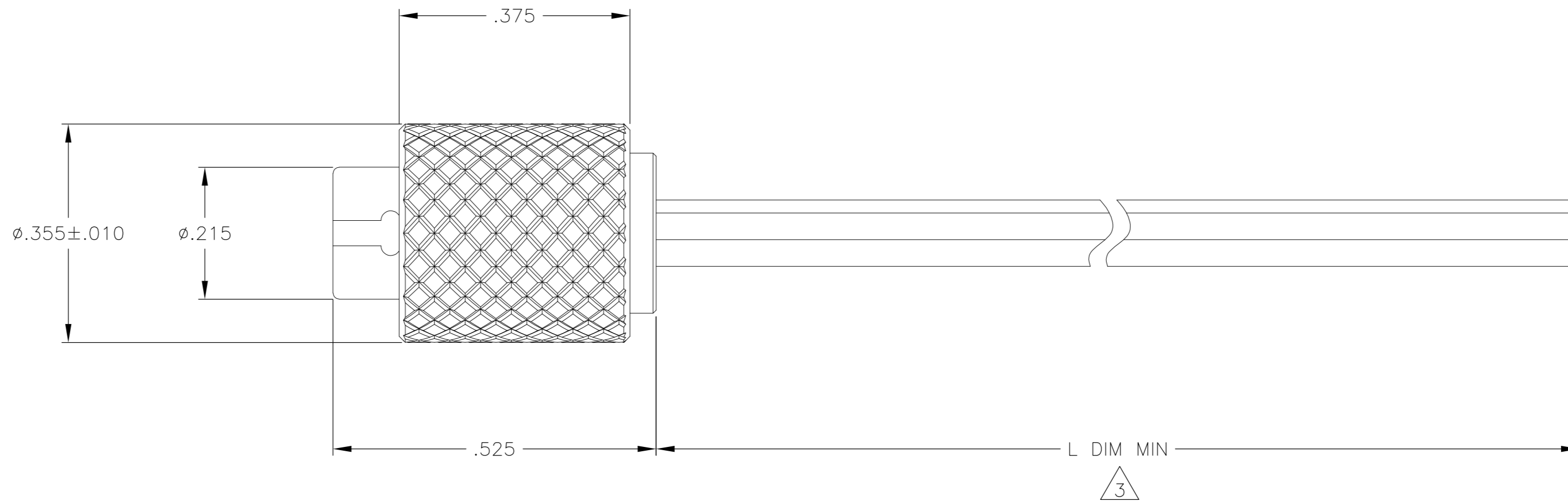

- 1 CONNECTOR BODY AND COUPLING NUT MATERIAL:
6061-T6 ALUMINUM, ELECTROLESS NICKEL PLATED PER SAE-AMS-C-26074 OR SAE-AMS-2404
- LOCKING RING MATERIAL: BERYLLIUM COPPER, ELECTROLESS NICKEL PLATED PER SAE-AMS-C-26074 OR SAE-AMS-2404
- INSULATOR MATERIAL: LIQUID CRYSTAL POLYMER (LCP) PER ASTM D5138
- O-RING MATERIAL: FLUOROSILICONE PER SAE-AMS-R-25988

- 2 TERMINATED WITH MADISON CABLE 30 AWG 10G TURBO TWIN PAIR
- 3 CABLE LENGTH IS AS INDICATED IN THE CORRESPONDING NANONICS PART NUMBER
- 4 CAVITY POSITIONS ARE SHOWN FOR REFERENCE ONLY AND ARE NOT MARKED ON THE PART
- 5 LUBRICATE O-RING WITH PARKER SUPER-O-LUBE PRIOR TO INSTALLATION
- 6 REFERENCE TE PRODUCT SPECIFICATION 108-32048 FOR PRODUCT DETAILS AND PERFORMANCE

THIS DRAWING IS A CONTROLLED DOCUMENT.		DWN M STORRY 31 JUL 2012		
DIMENSIONS: INCHES		CHK M STORRY 31 JUL 2012		
TOLERANCES UNLESS OTHERWISE SPECIFIED:		APVD M STORRY 31 JUL 2012	NAME	
0 PLC ± -		PRODUCT SPEC	PLUG ASSEMBLY, CIRCULAR, THREADED COUPLING, METAL, 8 POSITION, 10GbE, CeeLok FAS-T Nano Circular	
1 PLC ± -		APPLICATION SPEC	SIZE A2	CAGE CODE 0JPN9
2 PLC ± .010		WEIGHT -	DRAWING NO C=1925251	RESTRICTED TO -
3 PLC ± .005		CUSTOMER DRAWING	SCALE 6:1	SHEET 1 of 1
4 PLC ± -			REV A	
ANGLES ± 1°				
MATERIAL SEE NOTES	FINISH SEE NOTES			