

REVISIONS				
P	LTR	DESCRIPTION	DATE	BY
H		REVISED PER ECO-16-005483	14APR2016	AP

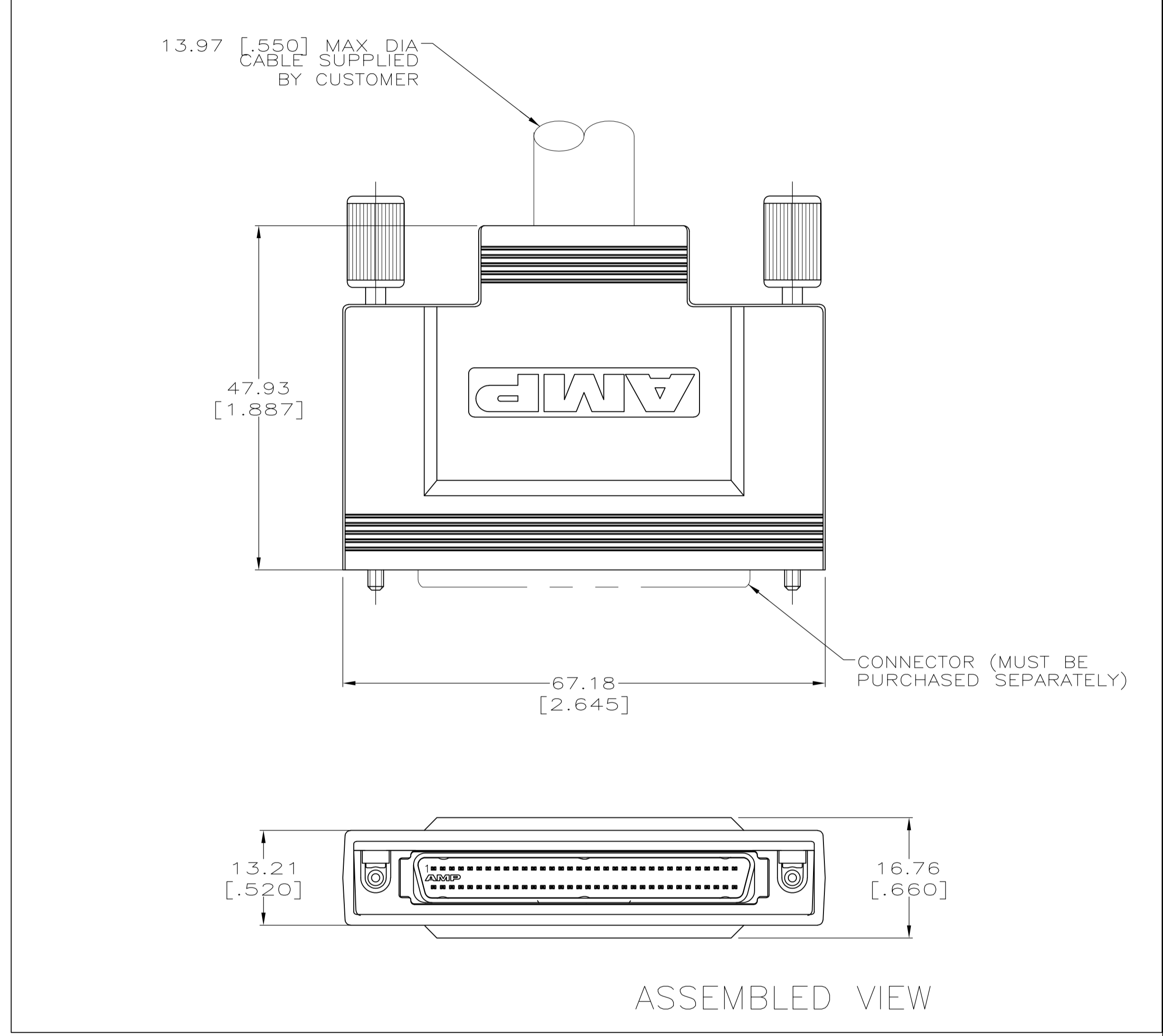
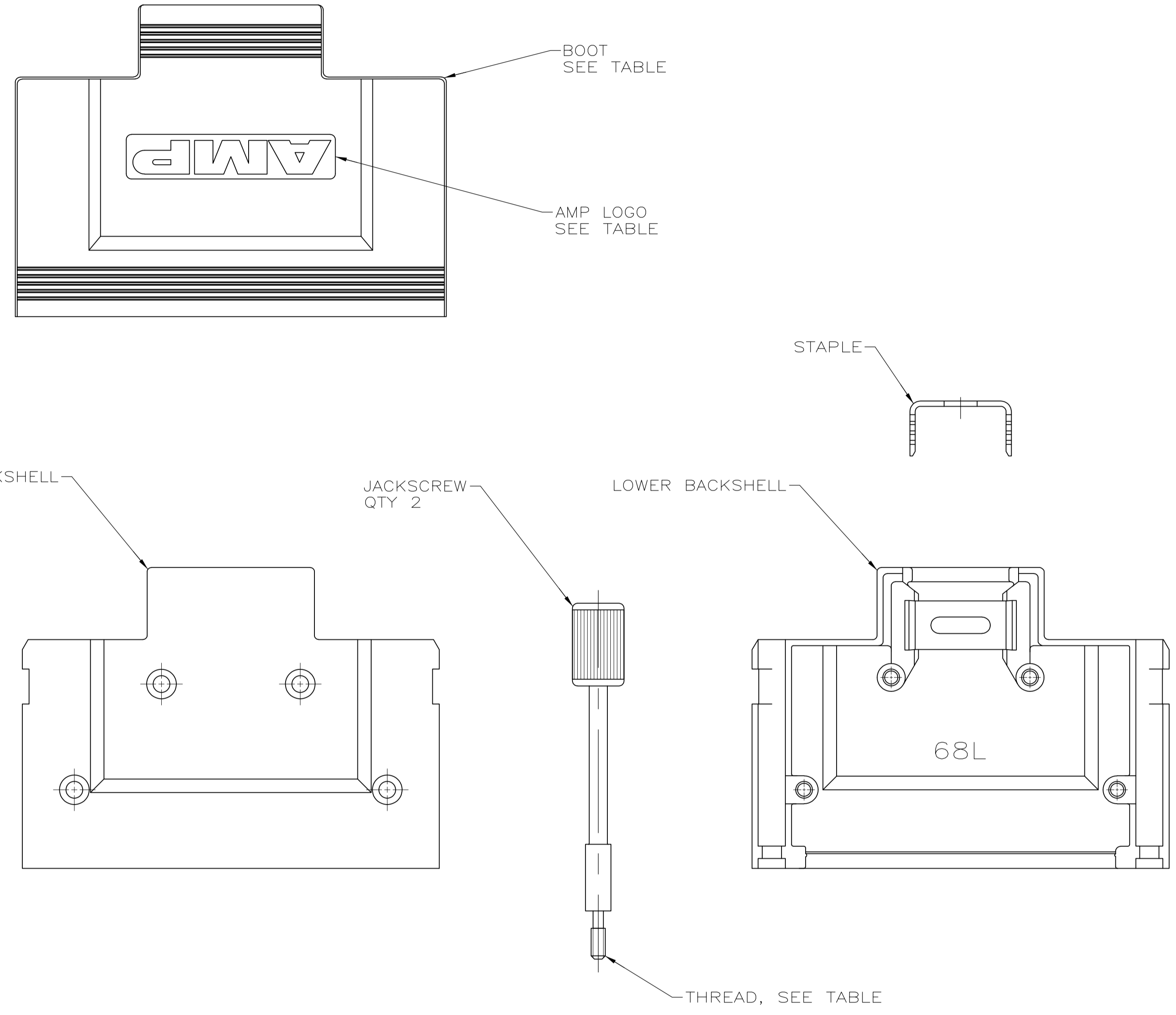

- 1 BOOT MATERIAL: PVC, BLACK.
- 2 BACKSHELL MATERIAL: ZINC PER ASTM B86.
- 3 JACKSCREW MATERIAL: STAINLESS STEEL.
- 4 STAPLE MATERIAL: CARBON STEEL PER ASTM A109.
- 5 SCREW MATERIAL: STAINLESS STEEL.
- 6 STAPLE: 1.27µm [.000050] MIN BRIGHT TIN-LEAD OVER 1.27µm [.000050] MIN NICKEL.
- 7 BULK PACKAGE.
- 8 INDIVIDUAL PACKAGE.
- 9 1.27µm [.000050] MIN BRIGHT TIN OVER 1.27µm [.000050] MIN NICKEL.

SUPERSEDED BY 5750752-1	YES	YES	2-56	750752-6
SUPERSEDED BY 750752-1	NO	YES	2-56	750752-5
	YES	YES	2-56	750752-4
OBSELETE	-	NO	2-56	750752-3
OBSELETE	YES	YES	4-40	750752-2
	YES	YES	2-56	750752-1
STAPLE FINISH	AMP LOGO	BOOT	JACKSCREW THREAD	PART NUMBER

THIS DRAWING IS A CONTROLLED DOCUMENT.

DIMENSIONS: INCHES	TOLERANCES UNLESS OTHERWISE SPECIFIED:	DIN D.GELTZ 4-17-91	4/27/91	STE TE Connectivity
0 PLC ± -	1 PLC ± -	2 PLC ± 0.51 [.020]	3 PLC ± -	4 PLC ± -
5 ANGLES ± -	6	NAME: BACKSHELL KIT, UNASSEMBLED, 68 POSITION, .050 SERIES AMPLITE		
MATERIAL	FINISH	WEIGHT	0.000000	A1 00779 C=750752
CUSTOMER DRAWING		SCALE	2:1	SHEET 1 OF 1 REV H