

DATE	REV	ECN	APP'D. BY
11-14-05	A1	7376	TRM
5-1-07	A2	8034	TRM
6-11-12	A3	9505	SMN
1-15-15	A4	10201	TRM

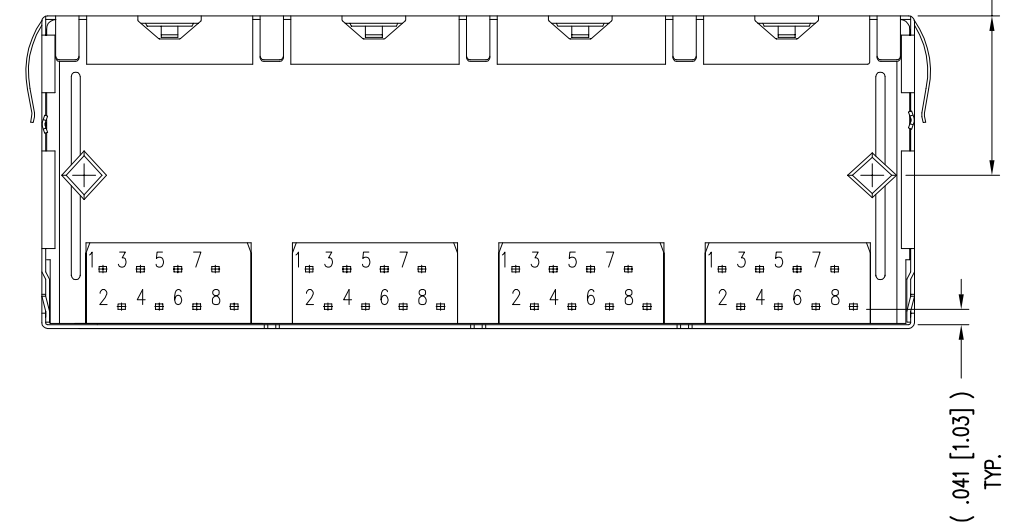

- NOTES:
- CONNECTOR MATERIALS:  
HOUSING: THERMOPLASTIC UL94 V-0  
CONTACT/SHIELD: COPPER ALLOY  
SHIELD PLATING: NICKEL  
CONTACT PLATING: SELECTIVE GOLD IN CONTACT AREA  
SEE CHART FOR PART NUMBER
  - FOR PRODUCT SPECIFICATION SEE PR022-01
  - TOLERANCES COMPLY WITH F.C.C. DIMENSION REQUIREMENTS.
  - THE SUGGESTED PANEL OPENING IS INTENDED TO GIVE USER THE ABILITY TO HAVE REASONABLE JACK/PANEL CLEARANCES, YET MAINTAIN GROUNDING CAPABILITY. THESE VARIABLES CAN BE ADJUSTED IN EITHER DIRECTION BUT MAY CARRY SOME CONSEQUENCES IN THE FORM OF LOWER MATING FORCES OR TIGHTER ASSEMBLY TOLERANCES.

50 MICRO-INCHES [1.26um]	SS-668804S-A-PG4-AC-50
30 MICRO-INCHES [0.76um]	SS-668804S-A-PG4-AC
CONTACT PLATING IN MATING AREA	PART NUMBER

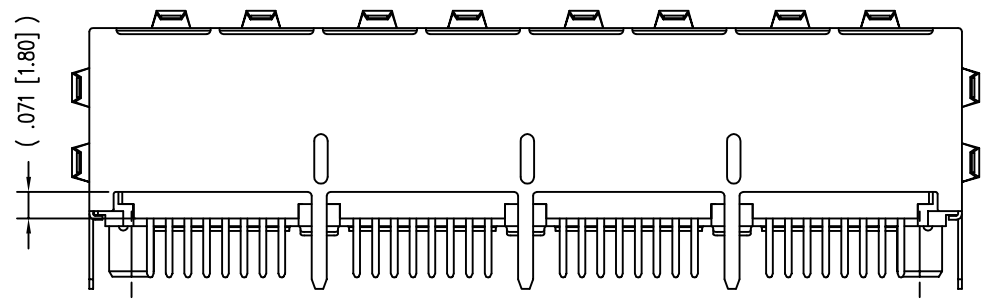
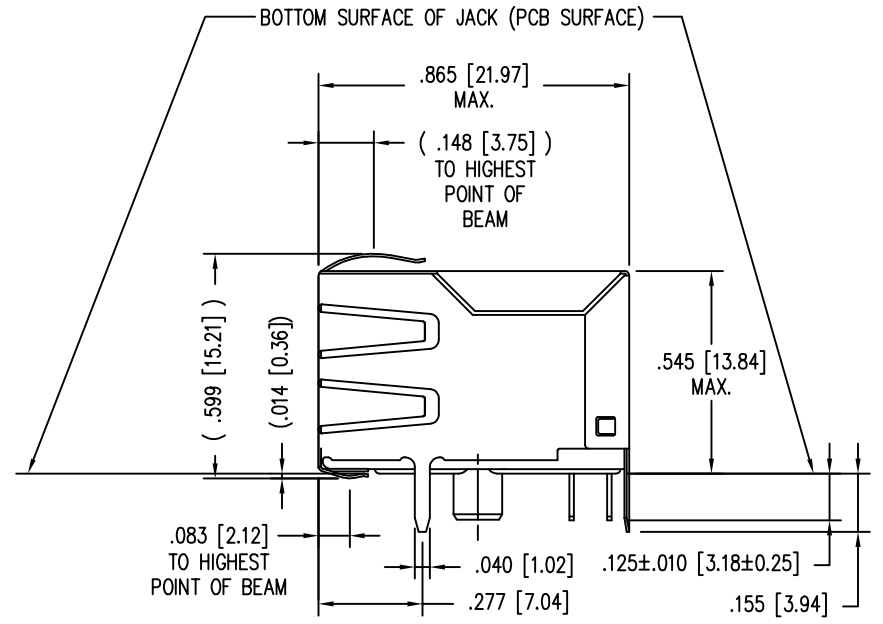
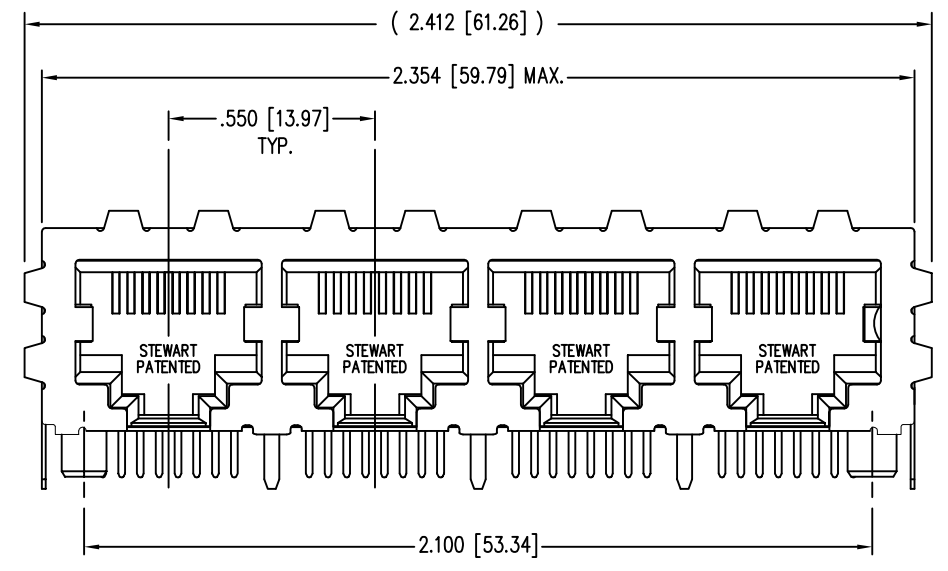
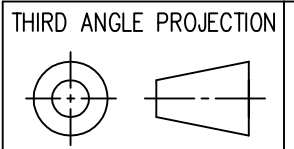

11118 Susquehanna Trail South  
Glen Rock, PA 17327-9199  
(717) 235-7512  
<http://www.stewartconnector.com>

DO NOT SCALE DRAWING  
DRAWING IS SUBJECT TO CHANGE WITHOUT NOTICE

TITLE: 4 PORT HARMONICA JACK, EMI-RFI ENHANCED SHIELD  
ESD GROUNDED, WITH PANEL GROUNDS

DIMENSIONS: INCHES [METRIC]  
UNLESS OTHERWISE SPECIFIED TOLERANCES ARE ±.005 [0.13] ANGLES ARE ± 1°

THIS DRAWING AND THE SUBJECT MATTER SHOWN THEREON ARE CONFIDENTIAL AND THE PROPRIETARY PROPERTY OF STEWART CONNECTOR AND SHALL NOT BE REPRODUCED, COPIED, OR USED IN ANY MANNER WITHOUT PRIOR WRITTEN CONSENT OF STEWART CONNECTOR. THIS PRODUCT MAY BE PROTECTED BY ONE OR MORE OF THE FOLLOWING US PATENTS: 5791942 6217391 6368159 6419526 6602097 687722 6964587 7048590 7086909 7568950 7686650 OTHER PATENTS MAY BE PENDING.

DRN BY: DAB DATE 8-21-03  
APPD BY: RGC DATE 8-21-03

SHEET NO. 1 OF 2

DWG NO. CT660101 REV. A4



B

B

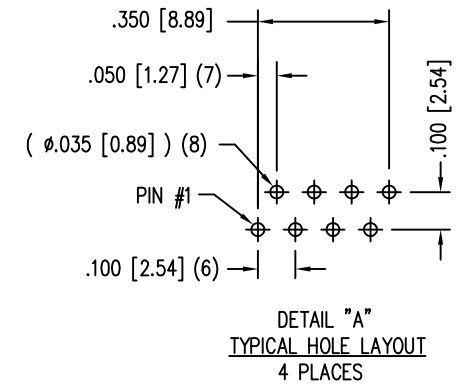
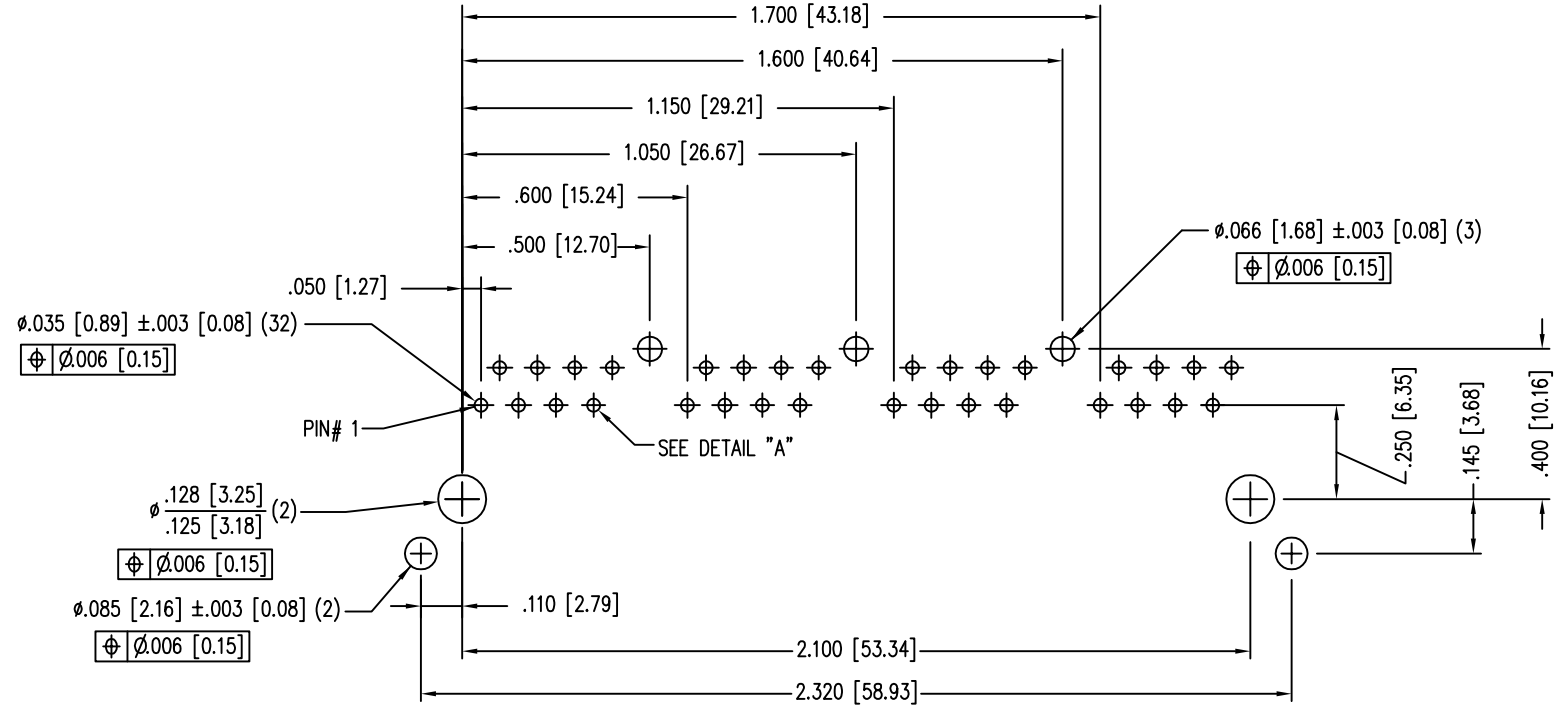

P.C.B. RECOMMENDED HOLE LAYOUT  
SEEN FROM COMPONENT SIDE  
ALL CENTERLINE DIMENSIONS ARE BASIC

A

A

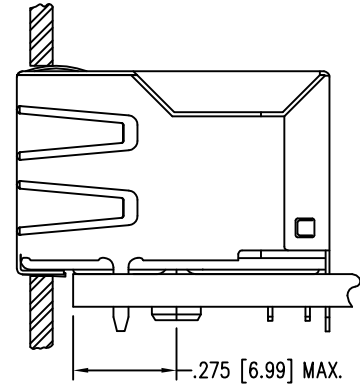
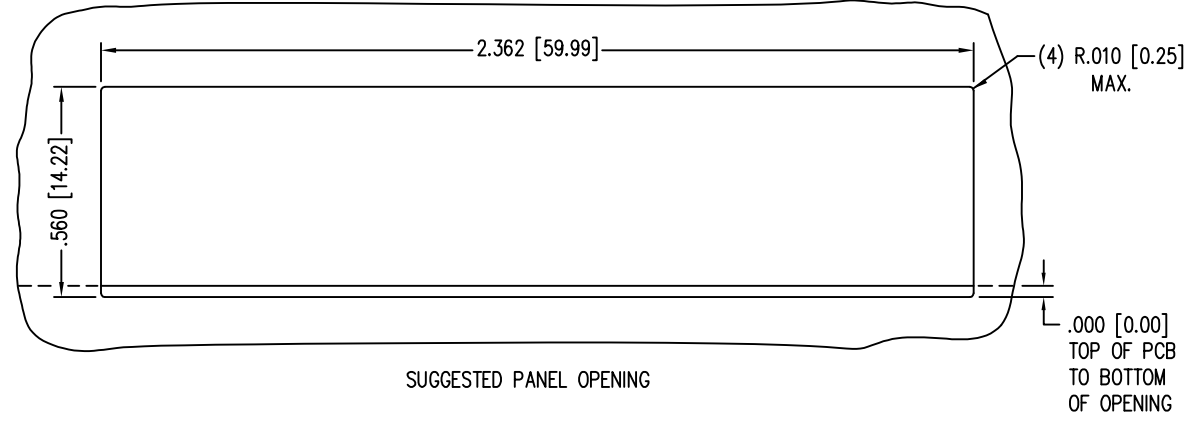

REV. 10/29/02



THIRD ANGLE PROJECTION 	 stewart CONNECTOR a bel group	11118 Susquehanna Trail South Glen Rock, PA 17327-9199 (717) 235-7512 <a href="http://www.stewartconnector.com">http://www.stewartconnector.com</a>
DO NOT SCALE DRAWING DRAWING IS SUBJECT TO CHANGE WITHOUT NOTICE	TITLE: 4 PORT HARMONICA JACK, EMI-RFI ENHANCED SHIELD ESD GROUNDED, WITH PANEL GROUNDS	
DIMENSIONS: INCHES [METRIC]	THIS DRAWING AND THE SUBJECT MATTER SHOWN THEREON ARE CONFIDENTIAL AND THE PROPRIETARY PROPERTY OF STEWART CONNECTOR AND SHALL NOT BE REPRODUCED, COPIED, OR USED IN ANY MANNER WITHOUT PRIOR WRITTEN CONSENT OF STEWART CONNECTOR. THIS PRODUCT MAY BE PROTECTED BY ONE OR MORE OF THE FOLLOWING US PATENTS: 5791942 6217391 6368159 6419526 6602097 687722 6964587 7048590 7086909 7568950 7686650 OTHER PATENTS MAY BE PENDING.	DRN BY: DAB DATE 8-21-03 APPD BY: RGC DATE 8-21-03
UNLESS OTHERWISE SPECIFIED TOLERANCES ARE ±.005 [0.13] ANGLES ARE ± 1°	SHEET NO. 2 OF 2	DWG NO. CT660101 REV. A4