

## Description

The 74LVC541A is an octal buffer/driver is designed for driving bus lines or buffer memory address registers. The 3-state control gate is a 2-input AND gate with active-low inputs so that, if either output enable ( $\overline{OE1}$  or  $\overline{OE2}$ ) input is high, all eight outputs are in the high-impedance state.

These devices feature inputs and outputs on opposite sides of the package that facilitate printed circuit board layout. The device is designed for operation with a power supply range of 1.65V to 3.6V.

The inputs are tolerant to 5.5V allowing this device to be used in a mixed voltage environment. The device is fully specified for partial power down applications using  $I_{OFF}$ . The  $I_{OFF}$  circuitry disables the output preventing damaging current backflow when the device is powered down.

## Features

- Supply Voltage Range from 1.65V to 3.6V
- Sinks or Sources 24mA at  $V_{CC} = 3V$
- CMOS Low Power Consumption
- $I_{OFF}$  Supports Partial-Power Down Operation
- Inputs or Outputs Accept Up to 5.5V
- Inputs Can Be Driven by 3.3V or 5V Allowing for Mixed Voltage Applications
- Schmitt Trigger Action at All Inputs
- Typical  $V_{OLP}$  (Quiet Output Ground Bounce) less than 0.8V with  $V_{CC} = 3.3V$  and  $T_A = +25^\circ C$
- Typical  $V_{OHV}$  (Quiet Output Dynamic VOH) greater than 2.0V with  $V_{CC} = 3.3V$  and  $T_A = +25^\circ C$
- ESD Protection Tested per JESD 22
  - Exceeds 200-V Machine Model (A115)
  - Exceeds 2000-V Human Body Model (A114)
  - Exceeds 1000-V Charged Device Model (C101)
- Latch-Up Exceeds 250mA per JESD 78, Class I
- All devices are:
  - **Totally Lead-Free & Fully RoHS compliant (Notes 1 & 2)**
  - **Halogen and Antimony Free. "Green" Device (Note 3)**

- Notes:
1. No purposely added lead. Fully EU Directive 2002/95/EC (RoHS) & 2011/65/EU (RoHS 2) compliant.
  2. See [http://www.diodes.com/quality/lead\\_free.html](http://www.diodes.com/quality/lead_free.html) for more information about Diodes Incorporated's definitions of Halogen and Antimony free, "Green" and Lead-Free.
  3. Halogen and Antimony free "Green" products are defined as those which contain <900ppm bromine, <900ppm chlorine (<1500ppm total Br + Cl) and <1000ppm antimony compounds.

## Pin Assignments

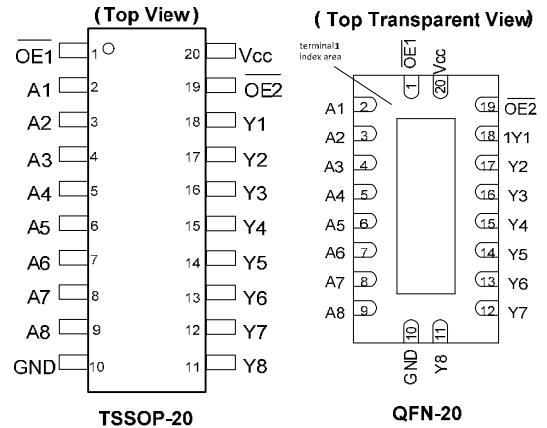

## Applications

- General Purpose Logic
- Bus Driving
- Power Down Signal Isolation
- Wide array of products such as:
  - PCs, Notebooks, Netbooks, Ultrabooks
  - Networking Computer Peripherals, Hard Drives, CD/DVD ROM
  - TV, DVD, DVR, set top box

**NEW PRODUCT**

## Ordering Information

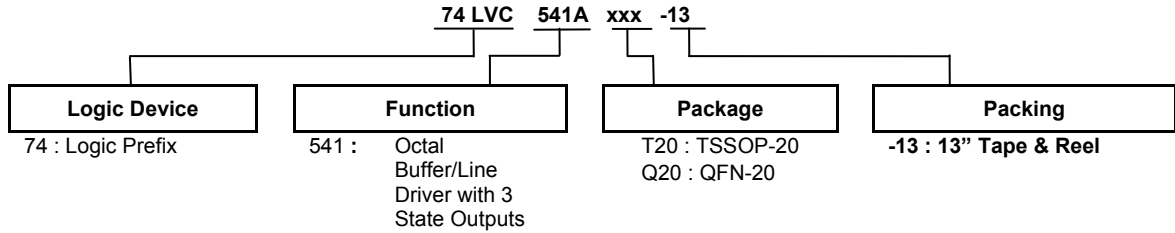

Part Number	Package Code	Package (Note 4 & 5)	Package Size	13" Tape and Reel	
				Quantity	Part Number Suffix
74LVC541AT20-13	T20	TSSOP-20	6.4mm X 6.5mm X 1.2mm 0.65 mm lead pitch	2500/Tape & Reel	-13
74LVC541AQ20-13	Q20	V-QFN4525-20	2.5mm X 4.5mm X 0.95mm 0.50 mm lead pitch	2500/Tape & Reel	-13

Notes: 4. Pad layout as shown on Diodes Inc. suggested pad layout document AP02001, which can be found on our website at <http://www.diodes.com/datasheets/ap02001.pdf>.  
 5. V-QFN4525-20 is a JEDEC recognized naming convention that specifies the package thickness category as V and the number 4525 describes the package as 4.5mm X 2.5mm.

## Pin Descriptions

Pin Number	Pin Name	Description
1	$\overline{OE1}$	Output Enable 1
2	A1	Data Input
3	A2	Data Input
4	A3	Data Input
5	A4	Data Input
6	A5	Data Input
7	A6	Data Input
8	A7	Data Input
9	A8	Data Input
10	GND	Ground
11	B8	Data Output
12	B7	Data Output
13	B6	Data Output
14	B5	Data Output
15	B4	Data Output
16	B3	Data Output
17	B2	Data Output
18	B1	Data Output
19	$\overline{OE2}$	Output Enable 2
20	V <sub>CC</sub>	Supply Voltage

## Logic Diagram

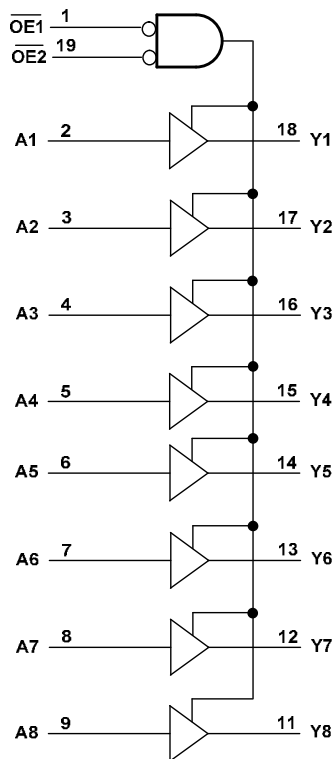

## Function Table

INPUTS			OUTPUT
$\overline{OE1}$	$\overline{OE2}$	A	Q
L	L	L	L
L	L	H	H
H	X	X	Z
X	H	X	Z

**Absolute Maximum Ratings** (Notes 6 & 7)

Symbol	Description	Rating	Unit
ESD HBM	Human Body Model ESD Protection	2	kV
ESD CDM	Charged Device Model ESD Protection	1	kV
ESD MM	Machine Model ESD Protection	200	V
V <sub>CC</sub>	Supply Voltage Range	-0.5 to +7.0	V
V <sub>I</sub>	Input Voltage Range	-0.5 to +7.0	V
I <sub>IK</sub>	Input Clamp Current V <sub>I</sub> < 0V	-20	mA
I <sub>OK</sub>	Output Clamp Current V <sub>O</sub> < 0V	-50	mA
I <sub>O</sub>	Continuous Output Current -0.5V < V <sub>O</sub> < V <sub>CC</sub> + 0.5V	±50	mA
I <sub>CC</sub>	Continuous Current Through V <sub>CC</sub>	100	mA
I <sub>GND</sub>	Continuous Current Through GND	-100	mA
T <sub>J</sub>	Operating Junction Temperature	-40 to +150	°C
T <sub>STG</sub>	Storage Temperature	-65 to +150	°C
P <sub>TOT</sub>	Total Power Dissipation	500	mW

- Notes:
- Stresses beyond the absolute maximum may result in immediate failure or reduced reliability. These are stress values and device operation should be within recommend values.
  - Forcing the maximum allowed voltage could cause a condition exceeding the maximum current or conversely forcing the maximum current could cause a condition exceeding the maximum voltage. The ratings of both current and voltage must be maintained within the controlled range..

**Recommended Operating Conditions** (Note 8)

Symbol	Parameter	Conditions	Min	Max	Unit
V <sub>CC</sub>	Supply Voltage	Operating	1.65	3.6	V
		Data Retention Only	1.5	—	V
V <sub>I</sub>	Input Voltage	—	0	5.5	V
V <sub>O</sub>	Output Voltage	—	0	V <sub>CC</sub>	V
I <sub>OH</sub>	High-Level Output Current	V <sub>CC</sub> = 1.65V	—	-4	mA
		V <sub>CC</sub> = 2.3V	—	-8	
		V <sub>CC</sub> = 2.7V	—	-12	
		V <sub>CC</sub> = 3.0V	—	-24	
I <sub>OL</sub>	Low-Level Output Current	V <sub>CC</sub> = 1.65V	—	4	mA
		V <sub>CC</sub> = 2.3V	—	8	
		V <sub>CC</sub> = 2.7V	—	12	
		V <sub>CC</sub> = 3.0V	—	24	
Δt/ΔV	Input Transition Rise or Fall Rate	—	—	10	ns/V
T <sub>A</sub>	Operating Free-Air Temperature	—	-40	+125	°C

- Note: 8. Unused inputs should be held at V<sub>CC</sub> or Ground.

**Electrical Characteristics**

Symbol	Parameter	Test Conditions	V <sub>CC</sub>	T <sub>A</sub> = -40°C to +85°C		T <sub>A</sub> = -40°C to +125°C		Unit
				Min	Max	Min	Max	
V <sub>IH</sub>	High-Level Input Voltage		1.65V to 1.95V	V <sub>CC</sub> X 0.65	—	V <sub>CC</sub> X 0.65	—	V
			2.3V to 2.7V	1.7	—	1.7	—	
			3.0V to 3.6V	2	—	2	—	
V <sub>IL</sub>	Low-Level input voltage		1.65V to 1.95V	—	V <sub>CC</sub> X 0.35	—	V <sub>CC</sub> X 0.35	V
			2.3V to 2.7V	—	0.7	—	0.7	
			3.0V to 3.6V	—	0.8	—	0.8	
V <sub>OH</sub>	High-Level Output Voltage	I <sub>OH</sub> = -50μA	1.65V to 3.6V	V <sub>CC</sub> -0.2	—	V <sub>CC</sub> -0.3	—	V
		I <sub>OH</sub> = -4mA	1.65V	1.2	—	1.05	—	
		I <sub>OH</sub> = -8mA	2.3V	1.7	—	1.65	—	
		I <sub>OH</sub> = -12mA	2.7V	2.2	—	2.05	—	
			3.0V	2.4	—	2.48	—	
I <sub>OH</sub> = -24mA	3.0V	2.3	—	2.0	—			
V <sub>OL</sub>	Low-Level Output Voltage	I <sub>OL</sub> = 100μA	1.65V to 3.6V	—	0.2	—	0.3	V
		I <sub>OL</sub> = 4mA	1.65V	—	0.45	—	0.65	
		I <sub>OL</sub> = 8mA	2.3V	—	0.60	—	0.80	
		I <sub>OL</sub> = 12mA	2.7V	—	0.40	—	0.60	
		I <sub>OL</sub> = 24mA	3.0V	—	0.55	—	0.80	
I <sub>OFF</sub>	Power Down Leakage Current	V <sub>I</sub> or V <sub>O</sub> = 0 or 5.5V	0V	—	±10	—	20	μA
I <sub>I</sub>	Input Current Control Pins	V <sub>I</sub> = GND or 5.5V	0 to 3.6V	—	±5	—	±20	μA
I <sub>OZ</sub>	Z-State Current including Input Current I/O Pins	V <sub>I</sub> = GND or 5.5V V <sub>O</sub> = 0 to 5.5V	3.6V	—	±5	—	±20	μA
I <sub>CC</sub>	Supply Current	V <sub>I</sub> = GND or V <sub>CC</sub> , I <sub>O</sub> = 0	3.6V	—	10	—	40	μA
ΔI <sub>CC</sub>	Additional Supply Current	One Input at V <sub>CC</sub> -0.6V I <sub>O</sub> = 0A	2.7V to 3.6V	—	500	—	5000	μA
C <sub>i</sub>	Input Capacitance	Control Pins	V <sub>I</sub> = GND or V <sub>CC</sub> 0V to 3.6V	4.0 typical		4.0 typical		pF
		I/O Pins		5.5 typical		5.5 typical		

**Switching Characteristics**

Symbol	Parameter	Test Conditions	V <sub>CC</sub>	T <sub>A</sub> = +25°C			T <sub>A</sub> = -40°C to +85°C		T <sub>A</sub> = -40°C to +125°C		Unit
				Min	Typ	Max	Min	Max	Min	Max	
t <sub>PD</sub>	Propagation Delay A <sub>N</sub> to Y <sub>N</sub>	Figure 1	1.8V ± 0.15V	1	6.0	13.2	1	17.7	1	18.9	ns
			2.5V ± 0.2V	1	3.9	8.6	1	9.6	1	10.7	
			2.7V	1	4.2	7.5	1	7.9	1	9.5	
			3.3V ± 0.3V	1.5	3.8	6.5	1.5	6.9	1.5	8.8	
t <sub>EN</sub>	Enable Time OE to Y <sub>N</sub>	Figure 1	1.8V ± 0.15V	1	7	14.8	1	17.5	1	18.5	ns
			2.5V ± 0.2V	1	4.5	13	1	16.5	1	17.5	
			2.7V	1	5.4	8.3	1	7.5	1	11.5	
			3.3V ± 0.3V	1.5	4.4	6.4	1.5	7.0	1.5	8.0	
t <sub>DIS</sub>	Disable Time OE to Y <sub>N</sub>	Figure 1	1.8V ± 0.15V	1	7.8	15.5	1	16.5	1	18.2	ns
			2.5V ± 0.2V	1	5	8.7	1	9.0	1	9.6	
			2.7V	1	4.4	7.5	1	7.7	1	10.0	
			3.3V ± 0.3V	1.7	4.1	6.9	1.7	7.0	1.7	9.0	
t <sub>sk(0)</sub>	Output Skew Time		3.3V ± 0.3V			1.0			1.5	ns	

## Operating Characteristics

 $T_A = +25^\circ\text{C}$ 

Symbol	Parameter	Test Conditions	V <sub>CC</sub>	Typ	Unit
C <sub>pd</sub>	Power dissipation capacitance per gate	F = 10 MHz	1.8V ± 0.15V	9.9	pF
			2.5V ± 0.2V	10.2	
			3.3V ± 0.3V	10.6	

## Package Characteristics

Symbol	Parameter	Package	Test Conditions	Min	Typ	Max	Unit
$\theta_{JA}$	Thermal Resistance Junction-to-Ambient	TSSOP-20	(Note 9)	—	74	—	°C/W
$\theta_{JC}$	Thermal Resistance Junction-to-Case	TSSOP-20	(Note 9)	—	15	—	°C/W
$\theta_{JA}$	Thermal Resistance Junction-to-Ambient	V-QFN4525-20	(Note 9)	—	67	—	°C/W
$\theta_{JC}$	Thermal Resistance Junction-to-Case	V-QFN4525-20	(Note 9)	—	20	—	°C/W

Note: 9. Test conditions for TSSOP-20 and V-QFN4525-20: Devices mounted on 4 layer FR-4 substrate PC board, 2oz copper, with minimum recommended pad layout per JESD 51-7.

**Parameter Measurement Information**

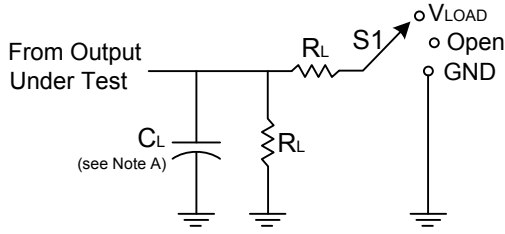

TEST	S1
$t_{PLH}/t_{PHL}$	Open
$t_{PLZ}/t_{PZL}$	$V_{LOAD}$
$t_{PHZ}/t_{PZH}$	GND

$V_{CC}$	Inputs		$V_M$	$V_{LOAD}$	$C_L$	$R_L$	$V_{\Delta}$
	$V_I$	$t_r/t_f$					
$1.8V \pm 0.15V$	$V_{CC}$	$\leq 2ns$	$V_{CC}/2$	$2 \times V_{CC}$	30pF	1K $\Omega$	0.15V
$2.5V \pm 0.2V$	$V_{CC}$	$\leq 2ns$	$V_{CC}/2$	$2 \times V_{CC}$	30pF	500 $\Omega$	0.15V
2.7V	2.7V	$\leq 2.5ns$	1.5V	6V	50pF	500 $\Omega$	0.3V
$3.3V \pm 0.3V$	2.7V	$\leq 2.5ns$	1.5V	6V	50pF	500 $\Omega$	0.3V

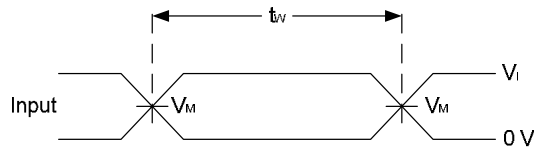

**Voltage Waveform Pulse Duration**

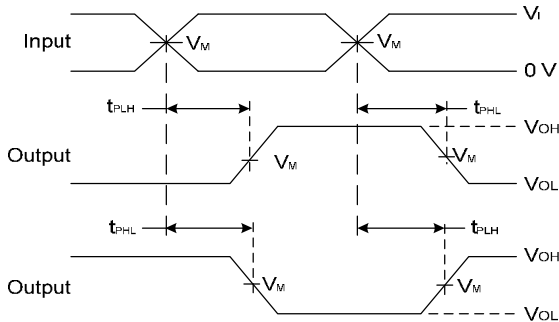

**Voltage Waveform Propagation Delay Times  
Inverting and Non Inverting Outputs**

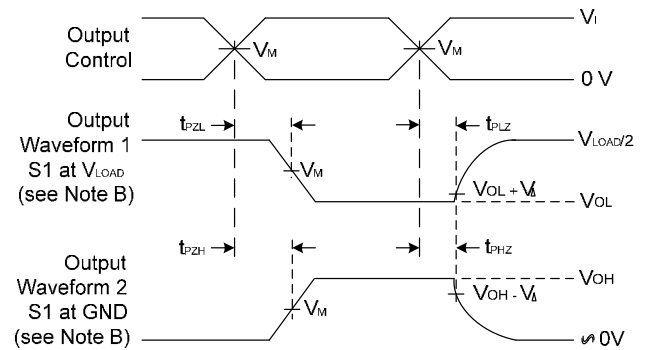

**Voltage Waveform Enable and Disable Times  
Low and High Level Enabling**

- Notes:
- A. Includes test lead and test apparatus capacitance.
  - B. All pulses are supplied at pulse repetition rate  $\leq 10$  MHz.
  - C. Inputs are measured separately one transition per measurement.
  - D.  $t_{PLZ}$  and  $t_{PHZ}$  are the same as  $t_{dis}$ .
  - E.  $t_{PZL}$  and  $t_{PZH}$  are the same as  $t_{ENO}$ .
  - F.  $t_{PLH}$  and  $t_{PHL}$  are the same as  $t_{PD}$ .

**Figure 1 Load Circuit and Voltage Waveforms**

**Marking Information**

(1) TSSOP20

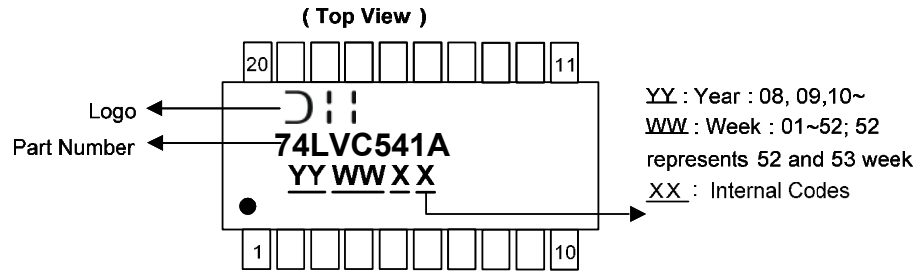

Part Number	Package
74LVC541AT20	TSSOP-20

(2) QFN-20 (V-QFN4525-20)

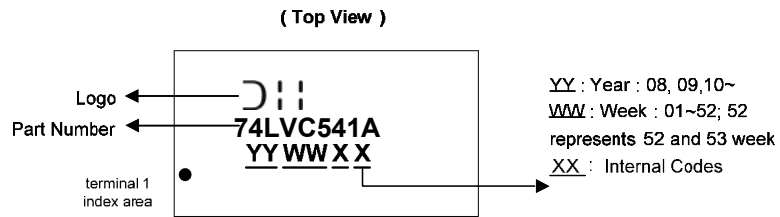

Part Number	Package
74LVC541AQ20	V-QFN4525-20

**Package Outline Dimensions**

Please see AP02002 at <http://www.diodes.com/datasheets/ap02002.pdf> for the latest version.

(1) TSSOP-20

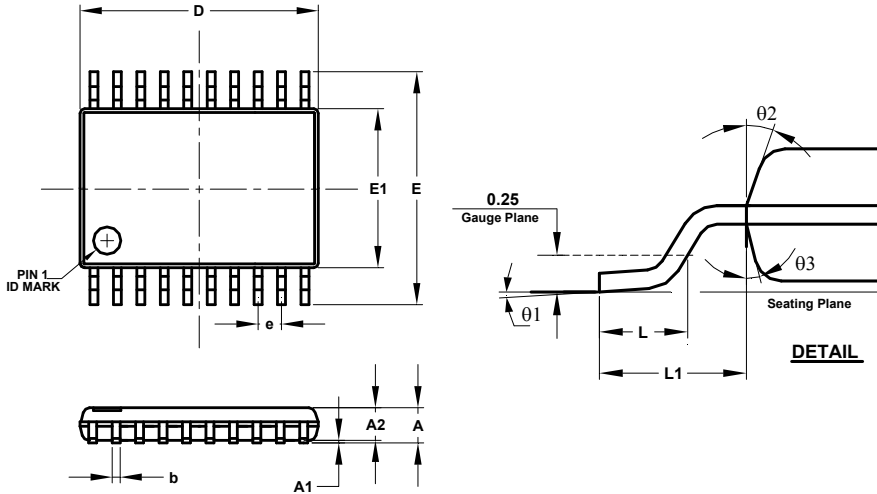

TSSOP-20			
Dim	Min	Max	Typ
A	-	1.20	-
A1	0.05	0.15	-
A2	0.80	1.05	-
b	0.19	0.30	-
c	0.09	0.20	-
D	6.40	6.60	6.50
E	6.20	6.60	6.40
E1	4.30	4.50	4.40
e	0.65 BSC		
L	0.45	0.75	0.60
L1	1.0 REF		
theta1	0°	8°	-
theta2	10°	14°	12°
theta3	10°	14°	12°
All Dimensions in mm			

(2) QFN-20 (V-QFN4525-20)

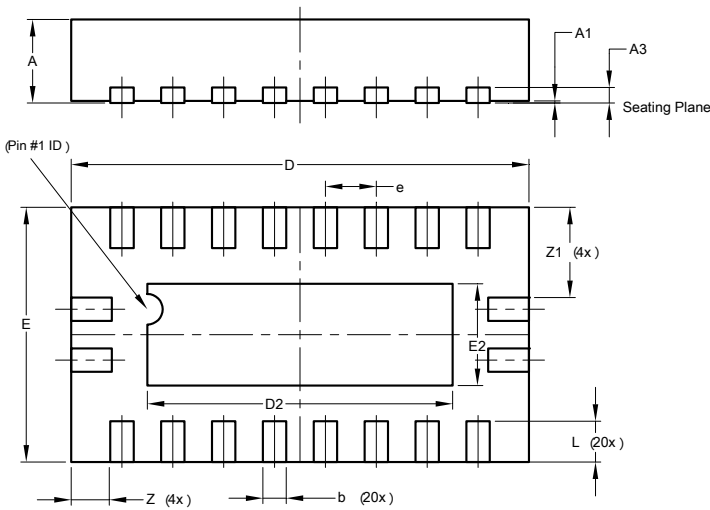

V-QFN4525-20			
Dim	Min	Max	Typ
A	0.75	0.85	0.80
A1	0.00	0.05	0.02
A3	-	-	0.15
b	0.18	0.30	0.23
D	4.45	4.55	4.50
D2	2.85	3.15	3.00
E	2.45	2.55	2.50
E2	0.85	1.15	1.00
e	0.50BSC		
L	0.30	0.50	0.40
Z	-	-	0.385
Z1	-	-	0.885
All Dimensions in mm			

NEW PRODUCT



## Suggested Pad Layout

Please see AP02001 at <http://www.diodes.com/datasheets/ap02001.pdf> for the latest version.

### (1) TSSOP-20

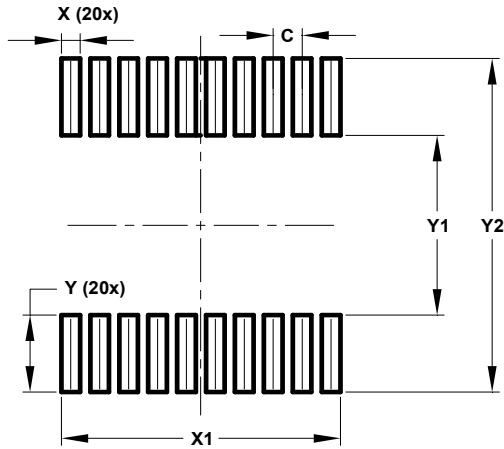

Dimensions	Value (in mm)
C	0.650
X	0.420
X1	6.270
Y	1.789
Y1	4.160
Y2	7.720

### (2) QFN-20 (V-QFN4525-20)

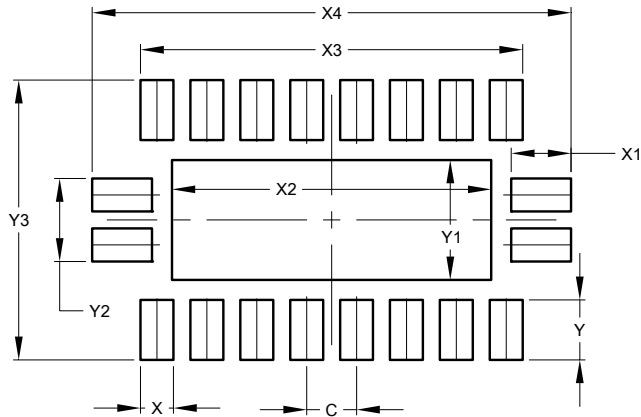

Dimensions	Value (in mm)
C	0.500
X	0.330
X1	0.600
X2	3.200
X3	3.830
X4	4.800
Y	0.600
Y1	1.200
Y2	0.830
Y3	2.800

**IMPORTANT NOTICE**

DIODES INCORPORATED MAKES NO WARRANTY OF ANY KIND, EXPRESS OR IMPLIED, WITH REGARDS TO THIS DOCUMENT, INCLUDING, BUT NOT LIMITED TO, THE IMPLIED WARRANTIES OF MERCHANTABILITY AND FITNESS FOR A PARTICULAR PURPOSE (AND THEIR EQUIVALENTS UNDER THE LAWS OF ANY JURISDICTION).

Diodes Incorporated and its subsidiaries reserve the right to make modifications, enhancements, improvements, corrections or other changes without further notice to this document and any product described herein. Diodes Incorporated does not assume any liability arising out of the application or use of this document or any product described herein; neither does Diodes Incorporated convey any license under its patent or trademark rights, nor the rights of others. Any Customer or user of this document or products described herein in such applications shall assume all risks of such use and will agree to hold Diodes Incorporated and all the companies whose products are represented on Diodes Incorporated website, harmless against all damages.

Diodes Incorporated does not warrant or accept any liability whatsoever in respect of any products purchased through unauthorized sales channel.

Should Customers purchase or use Diodes Incorporated products for any unintended or unauthorized application, Customers shall indemnify and hold Diodes Incorporated and its representatives harmless against all claims, damages, expenses, and attorney fees arising out of, directly or indirectly, any claim of personal injury or death associated with such unintended or unauthorized application.

Products described herein may be covered by one or more United States, international or foreign patents pending. Product names and markings noted herein may also be covered by one or more United States, international or foreign trademarks.

This document is written in English but may be translated into multiple languages for reference. Only the English version of this document is the final and determinative format released by Diodes Incorporated.

**LIFE SUPPORT**

Diodes Incorporated products are specifically not authorized for use as critical components in life support devices or systems without the express written approval of the Chief Executive Officer of Diodes Incorporated. As used herein:

A. Life support devices or systems are devices or systems which:

1. are intended to implant into the body, or
2. support or sustain life and whose failure to perform when properly used in accordance with instructions for use provided in the labeling can be reasonably expected to result in significant injury to the user.

B. A critical component is any component in a life support device or system whose failure to perform can be reasonably expected to cause the failure of the life support device or to affect its safety or effectiveness.

Customers represent that they have all necessary expertise in the safety and regulatory ramifications of their life support devices or systems, and acknowledge and agree that they are solely responsible for all legal, regulatory and safety-related requirements concerning their products and any use of Diodes Incorporated products in such safety-critical, life support devices or systems, notwithstanding any devices- or systems-related information or support that may be provided by Diodes Incorporated. Further, Customers must fully indemnify Diodes Incorporated and its representatives against any damages arising out of the use of Diodes Incorporated products in such safety-critical, life support devices or systems.

Copyright © 2014, Diodes Incorporated

[www.diodes.com](http://www.diodes.com)