

## FEATURES

- Compensates for cable and PCB trace attenuation and ISI jitter
- Programmable receiver equalization up to 24dB
- Programmable transmitter swing and de-emphasis
- Recovers data stream even when the differential signal eye is completely closed due to trace attenuation and ISI jitter
- Full SAS/SATA protocol support
- Configurable via external pins
- Leading edge power minimization in active and shutdown modes
- No external bias resistors or reference clocks required
- Channel mux mode, demux mode, 1 to 2 channels multicast, and Z-switch function mode
- Available in a 36-pin QFN package (4.0 x 7.5mm with 0.5mm pitch)

## BENEFITS

- Extends maximum cable length to over 8 meters and trace length over 48 inches in SAS/SATA applications
- Minimizes BER

## APPLICATIONS

- Blade servers, rack servers
- SAS/SATA instrumentation
- Storage systems
- Cabled SAS/SATA devices

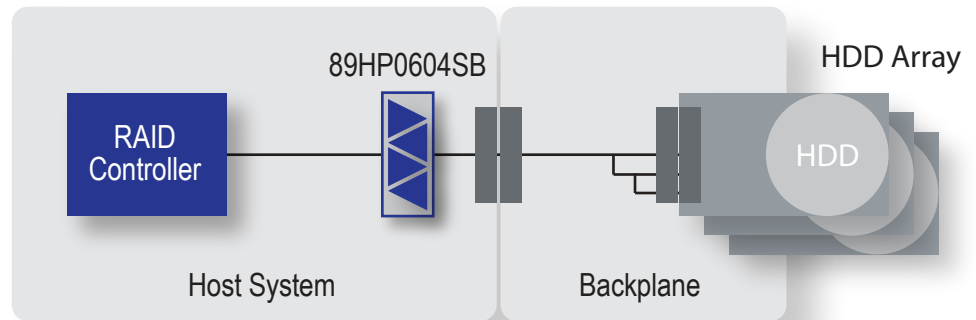

## Device Overview

The IDT 89HP0604SB is a 6Gbps SAS/SATA® Repeater device featuring IDT EyeBoost™ technology that compensates for cable and board trace attenuations and ISI jitter, thereby extending connection reach. The device is optimized for SAS/SATA high speed serial data streams and contains four data channels, each able to process 6Gbps transmission rates. Each channel consists of an input equalizer and amplifier, signal detection with glitch filter, as well as programmable output swing and de-emphasis. Allowing for application specific optimization, the 89HP0604SB, with its configurable receiver and transmitter features, is ideal for SAS/SATA applications using a wide combination of cables and board trace materials.

All modes of active data transfer are designed with minimized power consumption. In full shutdown mode, the part consumes less than 40mW in worst case environmental conditions.

## SAS/SATA Compliance

The device was designed to provide end users with features needed to comply with SAS/SATA system application requirements:

- SAS/SATA Out-of-Band (OOB) Support
- Jitter, eye opening, and all other AC and DC specifications.

## 89HP0604SB Block Diagram

The 89HP0604SB contains four high speed channels as shown. Each channel can be routed to different outputs. Depending on user configuration via mode selections, input traffic can be muxed or demuxed. Powerdown (PDB) is provided for state and channel control.

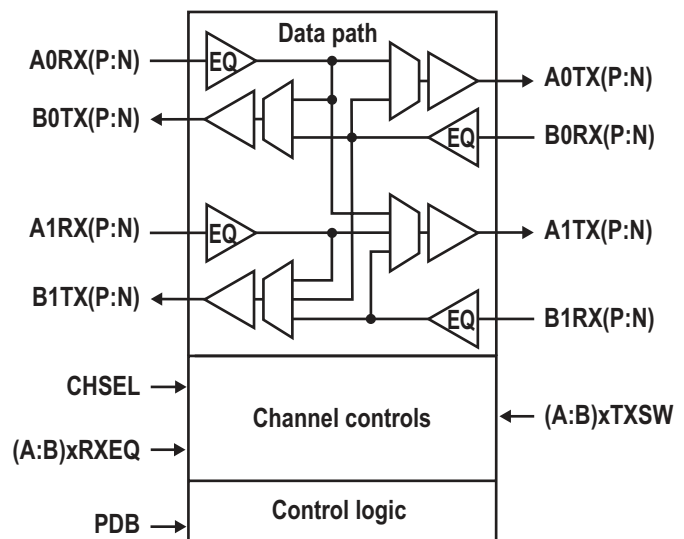

Discover what IDT know-how can do for you: [www.IDT.com](http://www.IDT.com)

DISCLAIMER Integrated Device Technology, Inc. (IDT) and its subsidiaries reserve the right to modify the products and/or specifications described herein at any time and at IDT's sole discretion. All information in this document, including descriptions of product features and performance, is subject to change without notice. Performance specifications and the operating parameters of the described products are determined in the independent state and are not guaranteed to perform the same way when installed in customer products. The information contained herein is provided without representation or warranty of any kind, whether express or implied, including, but not limited to, the suitability of IDT's products for any particular purpose, an implied warranty of merchantability, or non-infringement of the intellectual property rights of others. This document is presented only as a guide and does not convey any license under intellectual property rights of IDT or any third parties. IDT's products are not intended for use in life support systems or similar devices where the failure or malfunction of an IDT product can be reasonably expected to significantly affect the health or safety of users. Anyone using an IDT product in such a manner does so at their own risk, absent an express, written agreement by IDT.

Integrated Device Technology, IDT and the IDT logo are registered trademarks of IDT. Other trademarks and service marks used herein, including protected names, logos and designs, are the property of IDT or their respective third party owners. © Copyright 2012. All rights reserved.

PB\_89HP0604SB\_REVA0112