

P	LTR	DESCRIPTION	DATE	DWN	APVD
2		DRAFTING UPDATES	03SEP2020	SM	MZ
A		PRODUCT UNDER TESTING	24NOV2020	SM	MZ
A1		RELEASED	18MAR2022	SM	MZ
A2		RELEASED	25MAR2022	SM	MZ

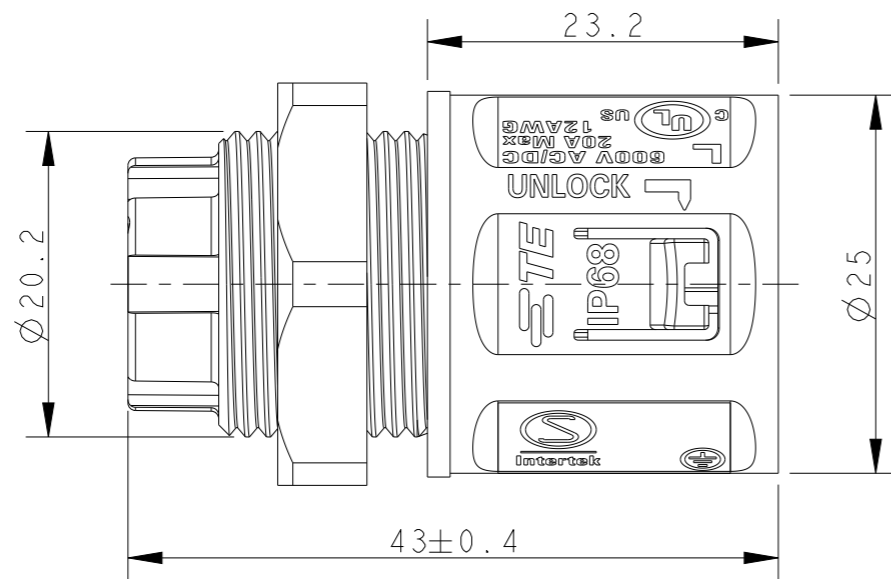

NOTES:

⚠ PART NUMBERS: 1-2359422-1 AND 1-2359422-2 ARE CRIMPED CONTACT VERSIONS. CONTACTS SUPPLIED SEPARATELY ON REELS, MUST PURCHASED ACCORDING TO WIRE SIZES. BELOW ARE THE CONTACT PART NUMBERS:

CONTACT P/N	WIRE SIZE
2359527-1	1.5mm ² TO 2.5mm ² 16AWG TO 14AWG
2359527-2	4.0mm ² 12AWG
2359527-3	18AWG

- MATERIALS:
PLASTICS: PBT+PC ALLOY, UL-V0, UV-FI
CONTACTS: COPPER ALLOY, TIN PLATED
SCREWS : STAINLESS STEEL
- OPERATING RATINGS :
VOLTAGE (max): 600Vac Max
CURRENT (max): 25A ON 4.0mm² & 20A ON 12AWG
TEMPERATURE : -40°C TO 85°C
IP RATING : IP67 & IP68
- FOR ASSEMBLY INSTRUCTIONS, REFER APPLICATION SPECIFICATION 114-133123
- PACKAGING: PPQ 200 pcs IN PE BAG

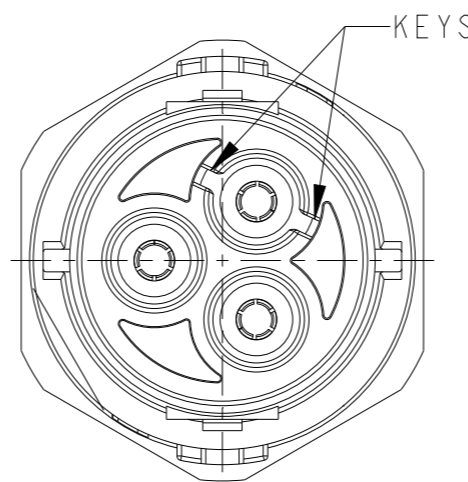
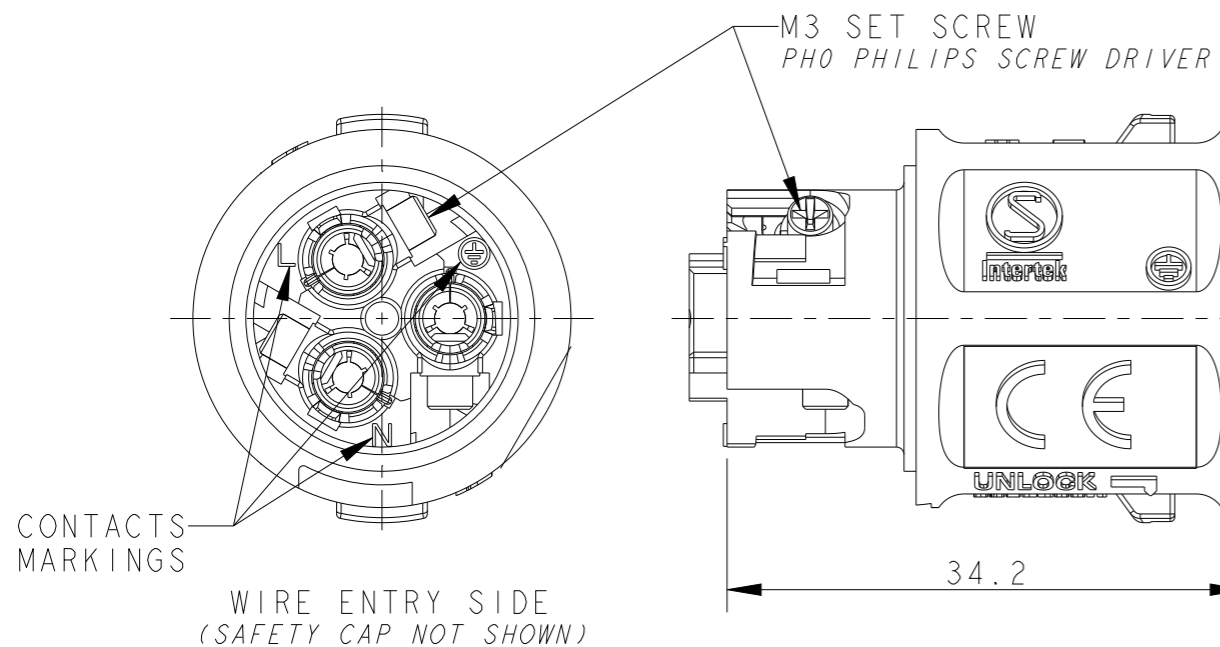

PANEL CUT-OUT RECOMMENDED SIZE

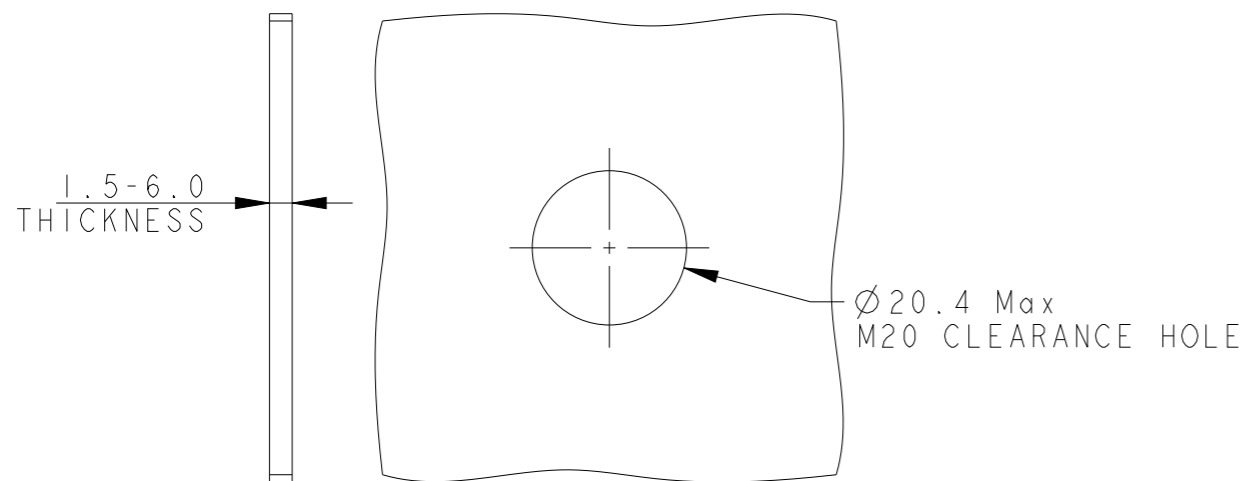

KEY	TERMINATION TYPE	DESCRIPTION	PART NUMBER
KEY B	CRIMP ⚠	PANEL MOUNT SOCKET CONNECTOR	1-2359422-2
KEY A			1-2359422-1
KEY B	SCREW	PANEL MOUNT SOCKET CONNECTOR	2359422-2
KEY A			2359422-1

THIS DRAWING IS A CONTROLLED DOCUMENT.		DWN SUBHASH.M 19AUG2020	TE Connectivity	
DIMENSIONS: mm		CHK M. ZUCCA 03SEP2020		
TOLERANCES UNLESS OTHERWISE SPECIFIED:		APVD PETER.OTT 24NOV2020	NAME NECTOR T, 3Pos, SOCKET CONNECTOR PANEL MOUNT	
0 PLC ±0.2 1 PLC ±0.2 2 PLC ±0.1 3 PLC ± 4 PLC ± ANGLES ±1°		PRODUCT SPEC 108-133123	SIZE A3	CAGE CODE 00779
MATERIAL		APPLICATION SPEC 114-133123	DRAWING NO C-2359422	RESTRICTED TO -
-		WEIGHT -	SCALE 2:1	
-		CUSTOMER DRAWING		SHEET 1 OF 2
				REV A2

CRIMP TERMINATION TYPE
1-2359422-1 & 1-2359422-2
REFER 114-133123 FOR DETAILED INSTRUCTION

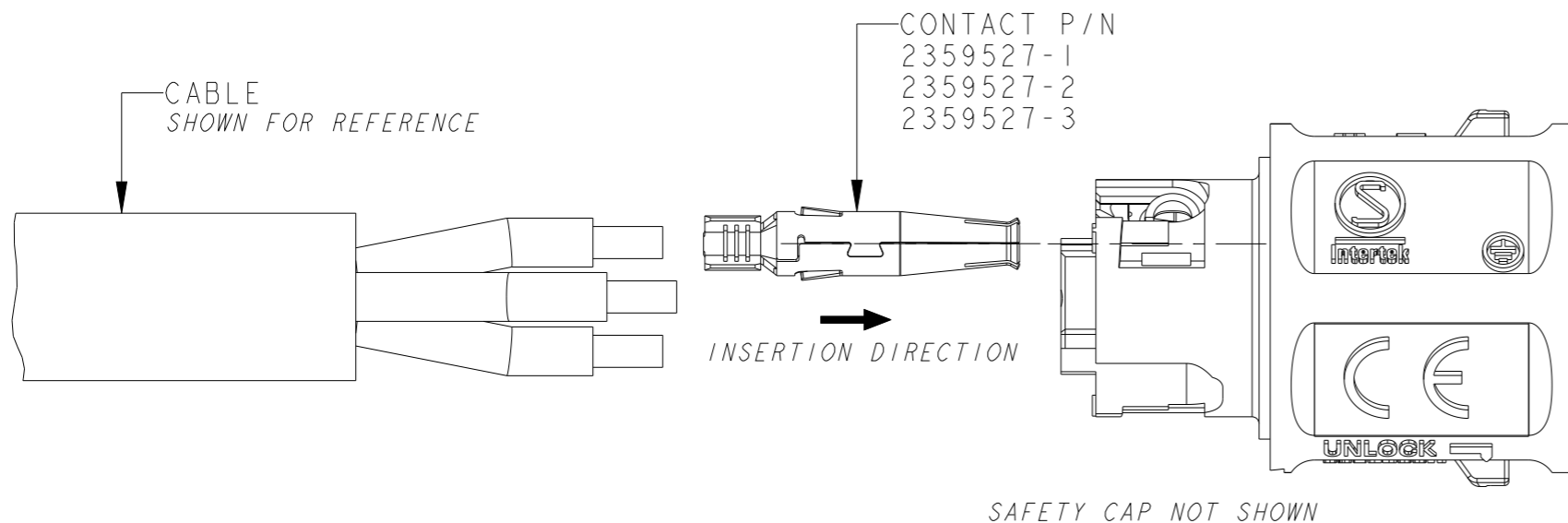

REVISIONS					
P	LTR	DESCRIPTION	DATE	DWN	APVD
-		SEE SHEET 1	-	-	-

EXPLODED COMPONENTS

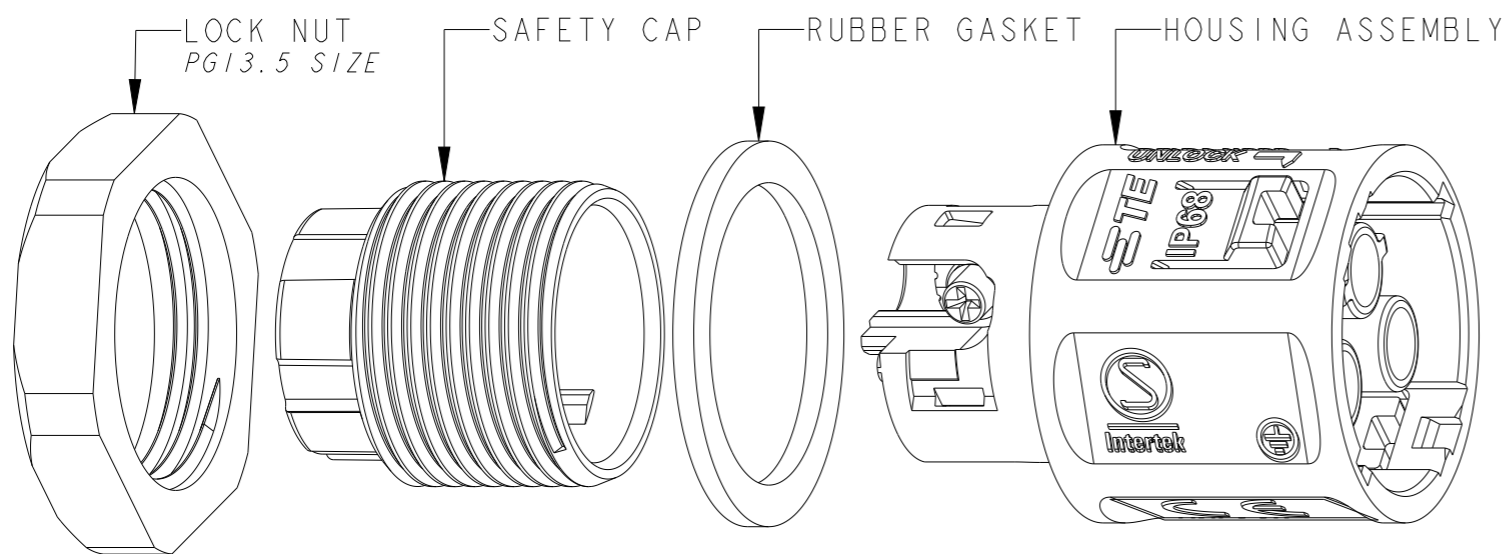

POLARIZING KEY A
2359422-1
1-2359422-1

POLARIZING KEY B
2359422-2
1-2359422-2

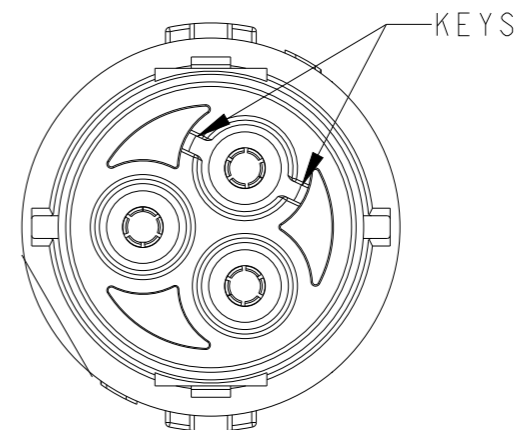

THIS DRAWING IS A CONTROLLED DOCUMENT.

DIMENSIONS: mm	TOLERANCES UNLESS OTHERWISE SPECIFIED:
	0 PLC ±0.2
	1 PLC ±0.2
	2 PLC ±0.1
	3 PLC ±
	4 PLC ±
	ANGLES ±°
MATERIAL	FINISH
-	-
-	-

DWN	19AUG2020
SUBHASH.M	
CHK	03SEP2020
M. ZUCCA	
APVD	24NOV2020
PETER.OTT	
PRODUCT SPEC	108-133123
APPLICATION SPEC	114-133123
WEIGHT	-
CUSTOMER DRAWING	



NAME
NECTOR T, 3Pos, SOCKET CONNECTOR
PANEL MOUNT

SIZE	CAGE CODE	DRAWING NO	RESTRICTED TO
A3	00779	C-2359422	-
SCALE	SHEET	OF	REV
2:1	2	2	A2