

THIS DRAWING IS UNPUBLISHED. RELEASED FOR PUBLICATION, 19 .
 © COPYRIGHT 19 BY AMP INCORPORATED, HARRISBURG, PA. ALL INTERNATIONAL RIGHTS RESERVED. AMP PRODUCTS MAY BE COVERED BY U.S. AND FOREIGN PATENTS AND/OR PATENTS PENDING.

| LOC | DIST | P | F | REVISIONS | | | DATE | APPROVED |
|-----|------|---|---|-----------|-----|--------------------------|------|----------|
| | | | | ZONE | LTR | DESCRIPTION | | |
| | | | | 0 | | RLSE NPR 1631 | - | - |
| ✓ | ✓ | | | A | | REV PER 0600-8209-99 JB | 3-99 | DE |
| | | | | B | | REV PER 063D-0091-99 JEB | 3-00 | DE |

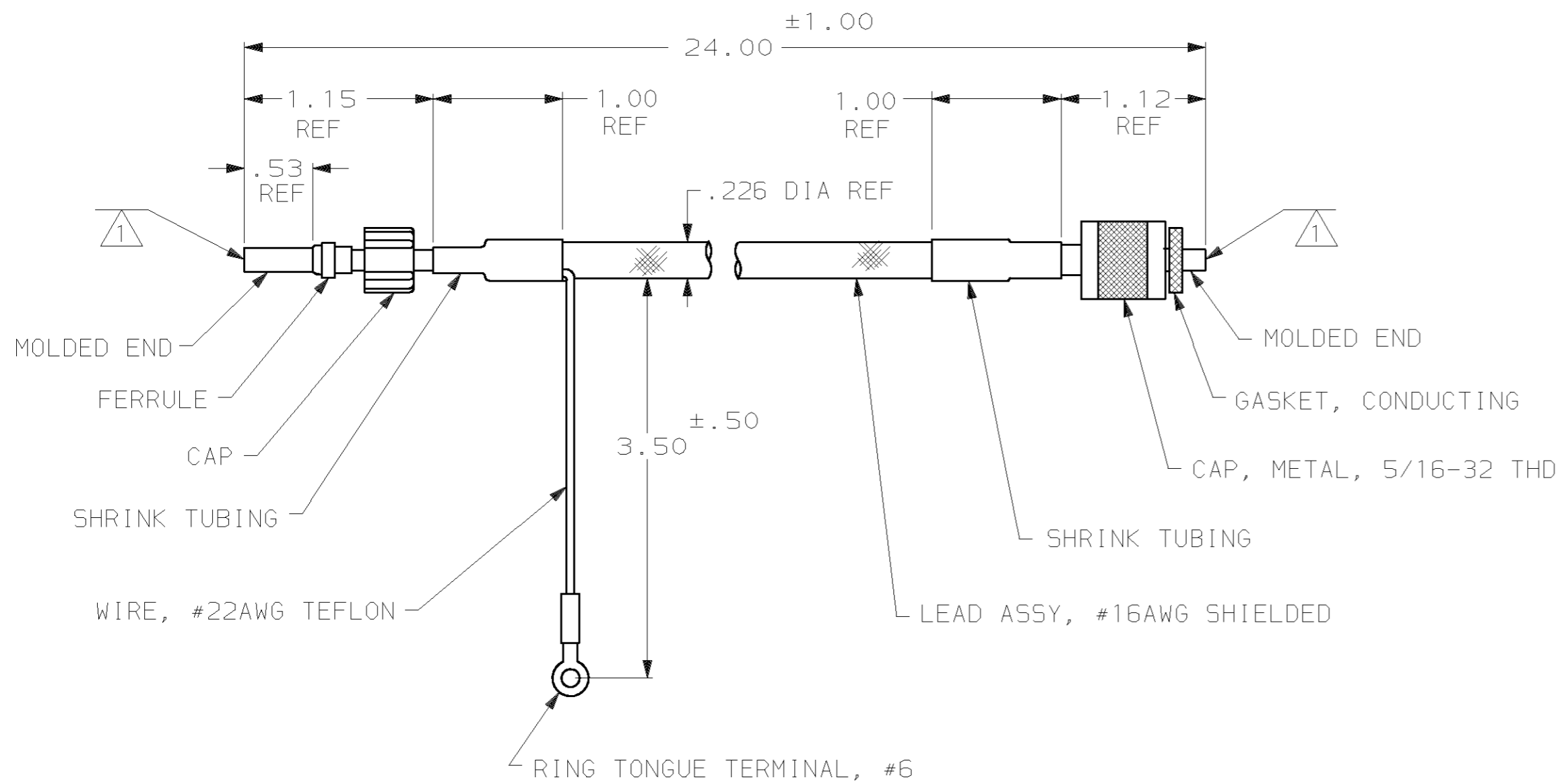

1 TO MATE WITH AMP LGH-1/2 RECEPTACLE WITH .53 BARREL DEPTH.
 2. MARKED PER MIL-STD-130.

868749-1
 PART NO

| | | | | | |
|---|---|------------------|--|---|---------|
| UNLESS OTHERWISE SPECIFIED DIMENSIONS ARE IN INCHES TOLERANCES ON : | | DR - | | AMP INCORPORATED Harrisburg, Pa. 17105 | |
| 2 PL DEC ± - | | CHK - | | | |
| 3 PL DEC ± - | | APPD - | | NAME LEAD ASSY, LGH-1/2 | |
| ANGLES ± - | | APPD - | | | |
| MATERIAL | - | PRODUCT SPEC | | SIZE | FSCM NO |
| FINISH | - | APPLICATION SPEC | | C | 00779 |
| | | WEIGHT | | DRAWING NO | 868749 |
| | | | | SCALE | NTS |
| | | | | SHEET | 1 OF 1 |