

Restrictions:

IDT's ZSPM4011B/12B/13B Evaluation Kit is designed for evaluation of the ZSPM4011B/ZSPM4012B/ZSMP4013B, laboratory setup, and module development only. This kit must not be used for module production and production test setups. IDT shall not be liable for any damages arising out of defects resulting from (i) delivered hardware (ii) non-observance of instructions contained in this manual, or (iii) misuse, abuse, use under abnormal conditions, or alteration by anyone other than IDT. To the extent permitted by law, IDT hereby expressly disclaims and User expressly waives any and all warranties, whether express, implied, or statutory, including, without limitation, implied warranties of merchantability and of fitness for a particular purpose, statutory warranty of non-infringement and any other warranty that may arise by reason of usage of trade, custom, or course of dealing.

Contents

1	Kit Contents	2
2	Introduction	2
3	General Overview	2
4	Setup	3
4.1.	Board Connectors	3
4.2.	Test and Probe Points	3
5	Board Options	4
5.1.	Input Capacitor Selection	4
5.2.	Output Capacitor Selection	4
5.3.	Schottky Diode	4
5.4.	PG Pull-up	4
6	Evaluation Board	5
6.1.	ZSPM4011B/12B/13B Evaluation Board Schematic	5
6.2.	ZSPM4011B/12B/13B Evaluation Board Layout	6
6.3.	ZSPM4011B/12B/13B Evaluation Board Bill of Materials	7
7	Ordering Information	8
8	Related Documents	8
9	Glossary	8
10	Document Revision History	9

1 Kit Contents

- ZSPM4011B/12B/13B Evaluation Board
- Kit User Guide

2 Introduction

The ZSPM4011B/12B/13B Evaluation Board is a complete, self-contained system to measure the performance and operating characteristics of the ZSPM4011B, ZSPM4012B, and ZSPM4013B switch mode regulators. The board contains various test points and jumpers to evaluate all functions of the devices.

3 General Overview

The input voltage for the board is supplied via the J1 connector as shown in Figure 3.1 below. Vin(+) is the top contact and Vin (GND) is on the bottom contact of this connector with the board orientation shown in Figure 3.1. The output of the power supply is set via jumpers on J3, and J2 can be used to connect any appropriate load to this power supply.

The voltage output connector is J2. Vout(+) is the top contact and Vout (-) is on the bottom contact of this connector with the orientation shown in Figure 3.1.

Figure 3.1 Overview of ZSPM4011B/12B/13B Evaluation Board

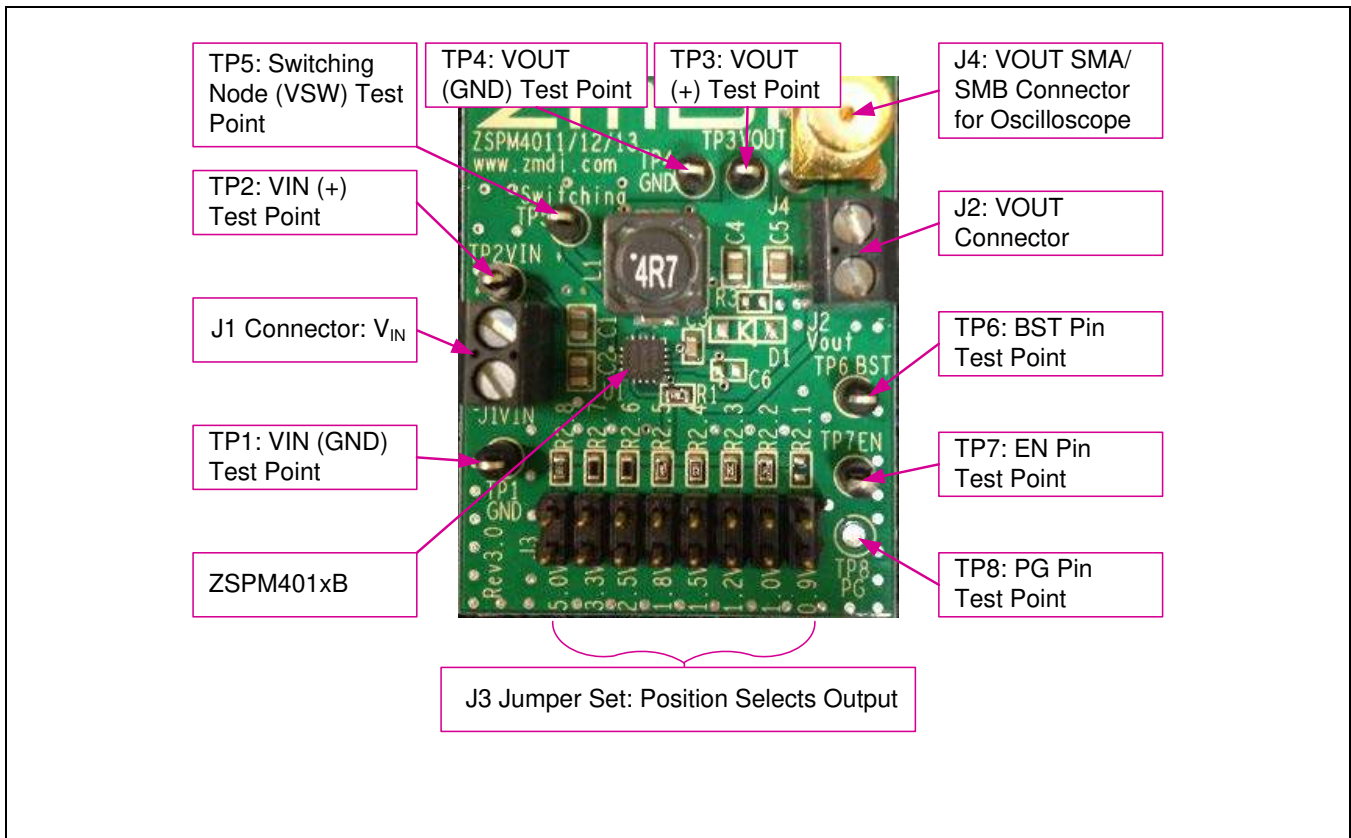

4 Setup

The setup for the ZSPM4011B/12B/13B Evaluation Board is very simple. An input voltage is applied at J1 and the output voltage is available at J2. The board is enabled by floating the TP7 test point (EN pin) or applying a voltage above 2V at this test point. If TP7 is pulled to GND, the device is disabled and input current should drop below 10μA.

The output voltage is adjusted by selecting the value of the R1 and R2 feedback resistors.

The equation for the output voltage in volts is

$$V_{out} = 0.9 * \left(1 + \left(\frac{R1}{R2.x} \right) \right)$$

Where

R2.x is the value of the resistor selected by the jumper on J3 (see Table 6.1 and Figure 6.1).

For example, values of R1=6.04K and R2.x=3.4kΩ provide a 2.5V output at J2. The jumper set, J3, allows selection of discrete resistor values for R2.x to program the output voltage to 0.9V, 1.0V, 1.2V, 1.5V, 1.8V, 2.5V, 3.3V, and 5V.

4.1. Board Connectors

The board contains the following connectors for external signals and supplies:

- J1:** The input supply voltage for the board. Note the polarity of the connection marked on the board.
- J2:** Output voltage from the regulator. Note the polarity of the connection marked on the board.
- J4:** SMA/SMB connection to VOUT for connecting to an oscilloscope to measure V_{OUT} ripple and transient response.

4.2. Test and Probe Points

The board contains the following test/probe points:

- TP2 VIN+:** Input supply voltage to the board.
- TP3 VOUT:** Output voltage (+) from the regulator.
- TP1 and TP4 GND:** Ground connections for the board. All of the GND test points are shorted together and connected to the GND pin of the IC.
- TP5 Switching:** Connects to the VSW pin. This test point is used to evaluate the switching node of the regulator.
- TP6 BST:** Connects to the BST pin. This test point is used to evaluate the bootstrap switching node of the regulator.
- TP7 EN:** Connects directly to the EN (enable) pin. The input range on the EN pin is 0 to 5V (typical). If this pin is pulled to GND, the IC will turn off, and if it is pulled above 2V, the IC will remain on.
- TP8 PG:** Connects directly to PG pin. If R3 is installed, it is a pull-up to VOUT. The voltage range on the PG pin is 0 to 5V (typical).

5 Board Options

5.1. Input Capacitor Selection

The input capacitor locations are C1 and C2. If substituting different values for these parts, note that one of these capacitors should be a low ESR ceramic type with a recommended minimum of 10 μ F. Refer to the data sheet for additional information and specifications for input capacitance.

5.2. Output Capacitor Selection

The output capacitor locations are C4 and C5. If substituting different values for these parts, note that low ESR single or parallel ceramic capacitors are recommended to keep the output ripple low. One of these capacitors should be a low ESR ceramic type. Refer to the data sheet for additional information and minimum specifications for output capacitance.

5.3. Schottky Diode

While D1 is not required, it can be populated to increase efficiency and provide a better load regulation. Care should be taken to select a diode that is rated to handle the output current supplied by the regulator.

5.4. PG Pull-up

The PG output is an open drain output. R3 can be populated to provide a pull-up to the VOUT supply.

6 Evaluation Board

6.1. ZSPM4011B/12B/13B Evaluation Board Schematic

Figure 6.1 Schematic for Evaluation Board Revision 3.0

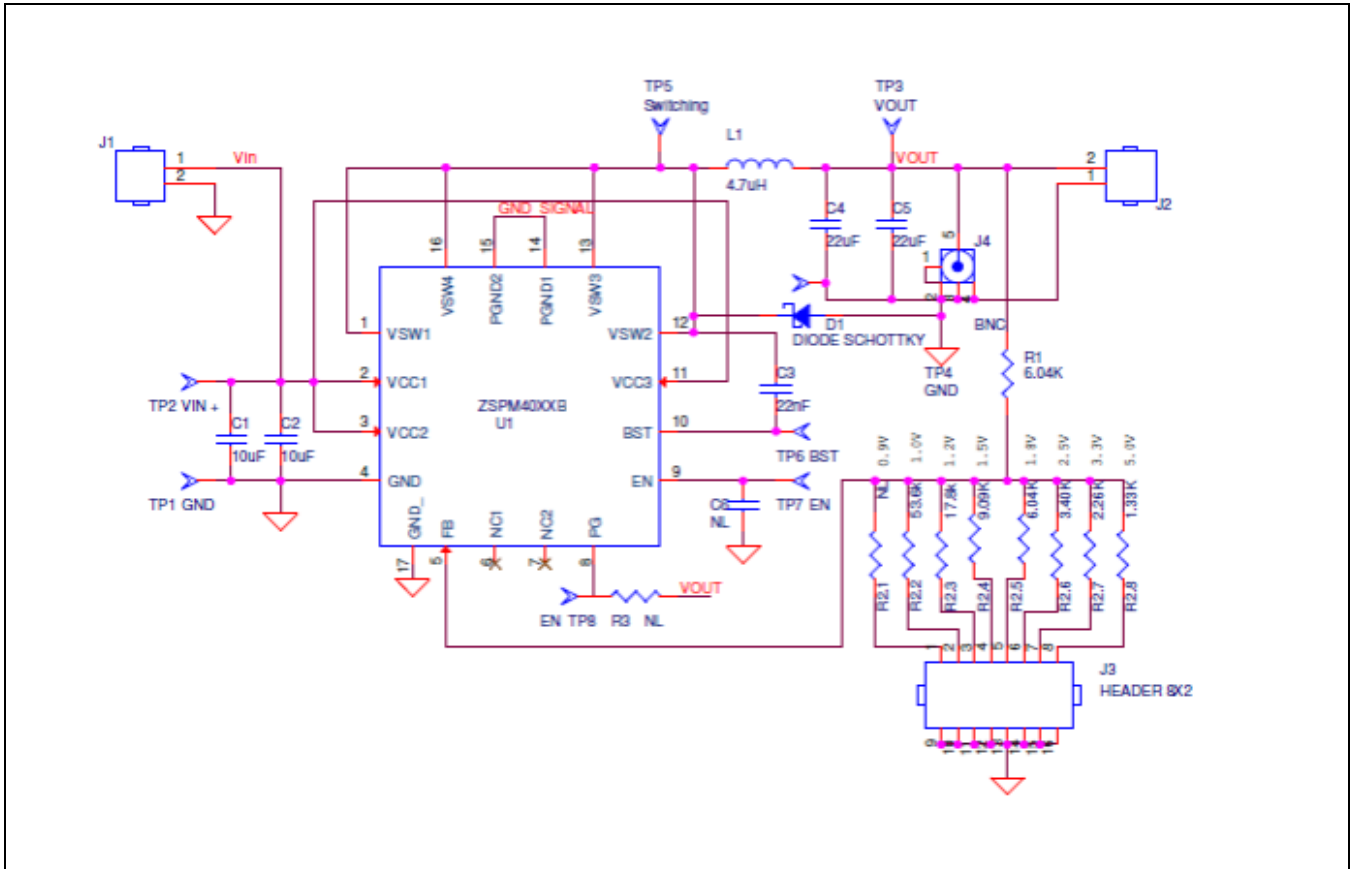

6.2. ZSPM4011B/12B/13B Evaluation Board Layout

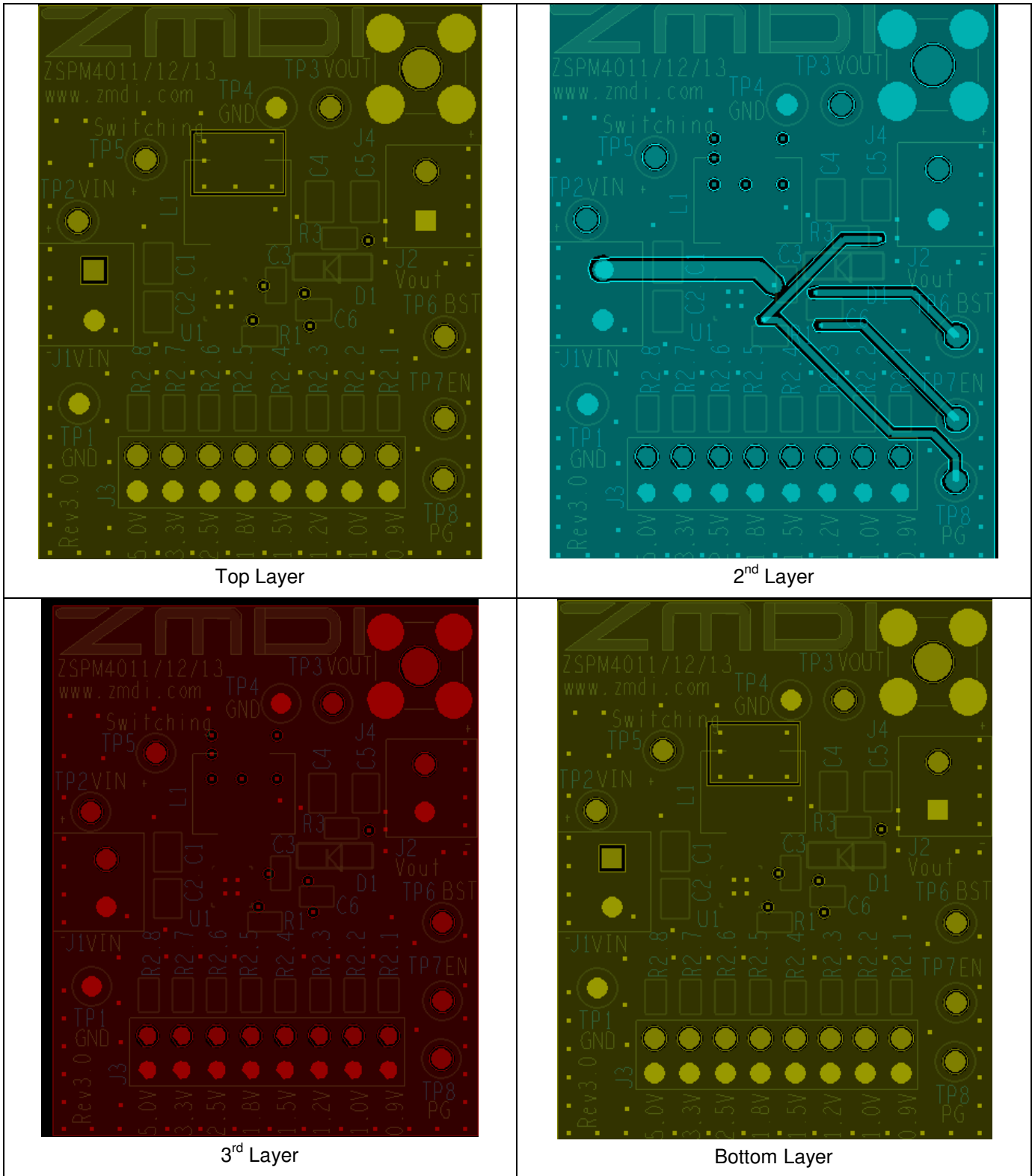

6.3. ZSPM4011B/12B/13B Evaluation Board Bill of Materials

Table 6.1 ZSPM4011B/12B/13B Evaluation Board Bill of Materials

Reference	Part	Footprint	Manufacturer	Manufacturer P/N
C1	10 μ F	805	TDK	C2012X5R1E106M
C2	10 μ F	805	TDK	C2012X5R1E106M
C3	22nF	603	TDK	C2012C0G1E223J
C4	22 μ F	805	Murata	GRM21BR60J226ME39L
C5	22 μ F	805	Murata	GRM21BR60J226ME39L
C6	NL	603		
D1	NI			
J1	ED1514-ND	OSTVQ021150	On-Shore	ED555/2DS
J2	ED1514-ND	OSTVQ021150	On-Shore	ED555/2DS
J3	HEADER 8X2	jumper16	Omron	XG8T-0631
J4	BNC	SMB	Tektronix	
L1	4.7 μ H	ind	Würth	7447779004
R1	6.04K	603	Susumu	RR0816P-6041-D-76H
R2.1	NL	603		
R2.2	53.6k	603	Susumu	RR0816P-5362-D-71C
R2.3	17.8k	603	Susumu	RR0816P-1782-D-25C
R2.4	9.09K	603	Susumu	RR0816P-9091-D-93H
R2.5	6.04K	603	Susumu	RR0816P-6041-D-76H
R2.6	3.40K	603	Susumu	RG1608P-3401-B-T5
R2.7	2.26K	603	Susumu	RG1608P-2261-B-T5
R2.8	1.33K	603	Welwyn	PCF0603R-1K33BT1
R3	NL	603		
TP1	GND	TP	Keystone	5001
TP2	VIN +	TP	Keystone	5001
TP3	VOUT	TP	Keystone	5001
TP4	GND	TP	Keystone	5001
TP5	Switching	TP	Keystone	5001
TP6	BST	TP	Keystone	5001
TP7	EN	TP	Keystone	5001
TP8	PG	TP	Keystone	5001
U1	ZSPM401XB	QFN 3mm x3mm x1mm	IDT	One of the following parts depending on the kit order code: ZSPM4011BA1W00 ZSPM4012BA1W00 ZSPM4013BA1W00

7 Ordering Information

Product Sales Code	Description
ZSPM4011BKIT	ZSPM4011BKIT: Evaluation kit for 0.9 to 5V, 1A synchronous buck converter
ZSPM4012BKIT	ZSPM4012BKIT: Evaluation kit for 0.9 to 5V, 2A synchronous buck converter
ZSPM4013BKIT	ZSPM4013BKIT: Evaluation kit for 0.9 to 5V, 3A synchronous buck converter

8 Related Documents

File Name
ZSPM4011B Datasheet
ZSPM4012B Datasheet
ZSPM4013B Datasheet

Visit www.IDT.com/ZSPM4011B, www.IDT.com/ZSPM4012B, and www.IDT.com/ZSPM4013B or contact your nearest sales office for the latest version of these documents.

9 Glossary

Term	Description
ESR	Equivalent Series Resistance
SMA	Sub-miniature version A coaxial RF connector
SMB	Sub-miniature version B coaxial RF connector

10 Document Revision History

Revision	Date	Description
1.00	April 18, 2013	First release for ZSPM4011B/ZSPM4012B/ZSPM4013B, based on ZSPM4011/ZSPM4012/ZSPM4013, silicon revision A.
	April 15, 2016	Changed to IDT branding.

IMPORTANT NOTICE AND DISCLAIMER

RENESAS ELECTRONICS CORPORATION AND ITS SUBSIDIARIES (“RENESAS”) PROVIDES TECHNICAL SPECIFICATIONS AND RELIABILITY DATA (INCLUDING DATASHEETS), DESIGN RESOURCES (INCLUDING REFERENCE DESIGNS), APPLICATION OR OTHER DESIGN ADVICE, WEB TOOLS, SAFETY INFORMATION, AND OTHER RESOURCES “AS IS” AND WITH ALL FAULTS, AND DISCLAIMS ALL WARRANTIES, EXPRESS OR IMPLIED, INCLUDING, WITHOUT LIMITATION, ANY IMPLIED WARRANTIES OF MERCHANTABILITY, FITNESS FOR A PARTICULAR PURPOSE, OR NON-INFRINGEMENT OF THIRD PARTY INTELLECTUAL PROPERTY RIGHTS.

These resources are intended for developers skilled in the art designing with Renesas products. You are solely responsible for (1) selecting the appropriate products for your application, (2) designing, validating, and testing your application, and (3) ensuring your application meets applicable standards, and any other safety, security, or other requirements. These resources are subject to change without notice. Renesas grants you permission to use these resources only for development of an application that uses Renesas products. Other reproduction or use of these resources is strictly prohibited. No license is granted to any other Renesas intellectual property or to any third party intellectual property. Renesas disclaims responsibility for, and you will fully indemnify Renesas and its representatives against, any claims, damages, costs, losses, or liabilities arising out of your use of these resources. Renesas' products are provided only subject to Renesas' Terms and Conditions of Sale or other applicable terms agreed to in writing. No use of any Renesas resources expands or otherwise alters any applicable warranties or warranty disclaimers for these products.

(Disclaimer Rev.1.0 Mar 2020)

Corporate Headquarters

TOYOSU FORESIA, 3-2-24 Toyosu,
Koto-ku, Tokyo 135-0061, Japan
www.renesas.com

Contact Information

For further information on a product, technology, the most up-to-date version of a document, or your nearest sales office, please visit:
www.renesas.com/contact/

Trademarks

Renesas and the Renesas logo are trademarks of Renesas Electronics Corporation. All trademarks and registered trademarks are the property of their respective owners.