

## RF-Hardened, Ultra-Low Noise Microphone with Bottom Port and Analog Output

### GENERAL DESCRIPTION

The INMP510\* is an RF-hardened, analog output, bottom-ported, omnidirectional MEMS microphone with high performance, ultra-low noise, and low power. The INMP510 consists of a MEMS microphone element, an impedance converter, and an output amplifier. The INMP510 sensitivity specification makes it an excellent choice for both near-field and far-field applications. The INMP510 is pin compatible with the INMP504 microphone. The INMP510 has a very high signal-to-noise ratio (SNR) and extended wideband frequency response, resulting in natural sound with high intelligibility. Low current consumption enables long battery life for portable applications.

The INMP510 is available in a miniature 3.35 × 2.5 × 0.98 mm surface-mount package. It is reflow solder compatible with no sensitivity degradation.

*\*Protected by U.S. Patents 7,449,356; 7,825,484; 7,885,423; and 7,961,897. Other patents are pending.*

### FUNCTIONAL BLOCK DIAGRAM

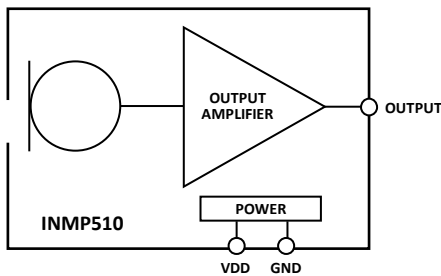

### APPLICATIONS

- Smartphones and Feature Phones
- Tablet Computers
- Teleconferencing Systems
- Digital Still and Video Cameras
- Bluetooth Headsets
- Notebook PCs
- Security and Surveillance

### FEATURES

- Tiny, 3.35 × 2.5 × 0.98 mm Surface-Mount Package
- High SNR of 65 dBA
- Acoustic Overload Point of 124 dB SPL
- Extended Frequency Response from 60 Hz to 20 kHz
- Omnidirectional Response
- Sensitivity of -38 dBV
- Sensitivity Tolerance of ±2 dB
- Enhanced Radio Frequency (RF) Performance
- Low Current Consumption of 180 μA
- Single-Ended Analog Output
- High PSR of -78 dBV
- Compatible with Sn/Pb and Pb-Free Solder Processes
- RoHS/WEEE Compliant

### ORDERING INFORMATION

PART	TEMP RANGE
INMP510ACEZ-R0*	-40°C to +85°C
INMP510ACEZ-R7†	-40°C to +85°C
EV_INMP510-FX	—

\* – 13” Tape and Reel

† – 7” Tape and reel is to be discontinued. Contact [sales@invensense.com](mailto:sales@invensense.com) for availability.

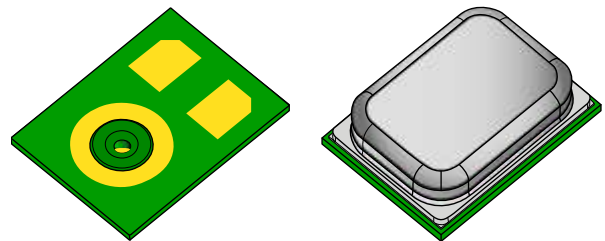

**TABLE OF CONTENTS**

General Description ..... 1

Applications ..... 1

Features ..... 1

Functional Block Diagram ..... 1

Ordering Information..... 1

Table of Contents ..... 2

Specifications ..... 3

    Table 1. Electrical Characteristics ..... 3

Absolute Maximum Ratings ..... 4

    Table 2. Absolute Maximum Ratings ..... 4

    ESD Caution ..... 4

    Soldering Profile..... 5

    Table 3. Recommended Soldering Profile\* ..... 5

Pin Configurations And Function Descriptions ..... 6

    Table 4. Pin Function Descriptions..... 6

Typical Performance Characteristics..... 7

Applications Information ..... 8

    Connecting to Audio Codecs..... 8

SUPPORTING Documents..... 9

    Evaluation Board User Guide..... 9

    Application Notes (General) ..... 9

    Application Notes (Product Specific) ..... 9

PCB Design And Land Pattern Layout ..... 10

Handling Instructions ..... 11

    Pick And Place Equipment ..... 11

    Reflow Solder ..... 11

    Board Wash..... 11

Outline Dimensions..... 12

    Ordering Guide ..... 13

    Revision History ..... 13

    Compliance Declaration Disclaimer ..... 14

**SPECIFICATIONS**

**TABLE 1. ELECTRICAL CHARACTERISTICS**

( $T_A = -40$  to  $85^\circ\text{C}$ ,  $V_{DD} = 1.5$  to  $3.63$  V, unless otherwise noted. All minimum and maximum specifications are guaranteed across temperature and voltage, and are specified in Table 1, unless otherwise noted. Typical specifications are not guaranteed.)

PARAMETER	CONDITIONS	MIN	TYP	MAX	UNITS	NOTES
<b>PERFORMANCE</b>						
Directionality			Omni			
Sensitivity	1 kHz, 94 dB SPL	-40	-38	-36	dBV	
Signal-to-Noise Ratio (SNR)			65		dB	
Equivalent Input Noise (EIN)			29		dB SPL	
Dynamic Range	Derived from EIN and maximum acoustic input		91		dB	
Frequency Response	Low frequency -3 dB point		60		Hz	1
	High frequency -3 dB point		>20		kHz	
Total Harmonic Distortion (THD)	105 dB SPL		0.2	1	%	
Power-Supply Rejection (PSR)	217 Hz, 100 mVp-p square wave superimposed on $V_{DD} = 1.8$ V (A-weighted)		-78		dBV	
Power-Supply Rejection Ratio (PSRR)	1 kHz, 100 mV p-p sine wave superimposed on $V_{DD} = 1.8$ V		-55		dB	
Acoustic Overload Point	10% THD		124		dB SPL	
<b>POWER SUPPLY</b>						
Supply Voltage ( $V_{DD}$ )		1.5		3.63	V	
Supply Current ( $I_S$ )						
	$V_{DD} = 1.8$ V		180	220	$\mu\text{A}$	
	$V_{DD} = 3.3$ V		210	250	$\mu\text{A}$	
<b>OUTPUT CHARACTERISTICS</b>						
Output Impedance ( $Z_{OUT}$ )			350		$\Omega$	
Output DC Offset			0.7		V	
Maximum Output Voltage	131 dB SPL input		0.398		V rms	
Noise Floor	20 Hz to 20 kHz, A-weighted, rms		-103		dBV	

**Note 1:** See Figure 3 and Figure 4.

**ABSOLUTE MAXIMUM RATINGS**

Stress above those listed as Absolute Maximum Ratings may cause permanent damage to the device. These are stress ratings only and functional operation of the device at these conditions is not implied. Exposure to the absolute maximum ratings conditions for extended periods may affect device reliability.

**TABLE 2. ABSOLUTE MAXIMUM RATINGS**

PARAMETER	RATING
Supply Voltage (VDD)	-0.3 V to +3.63 V
Sound Pressure Level	160 dB
Mechanical Shock	10,000 g
Vibration	Per MIL-STD-883 Method 2007, Test Condition B
Operating Temperature Range	-40°C to +85°C
Storage Temperature Range	-55°C to +150°C

**ESD CAUTION**



ESD (electrostatic discharge) sensitive device. Charged devices and circuit boards can discharge without detection. Although this product features patented or proprietary protection circuitry, damage may occur on devices subjected to high energy ESD. Therefore proper ESD precautions should be taken to avoid performance degradation or loss of functionality.

SOLDERING PROFILE

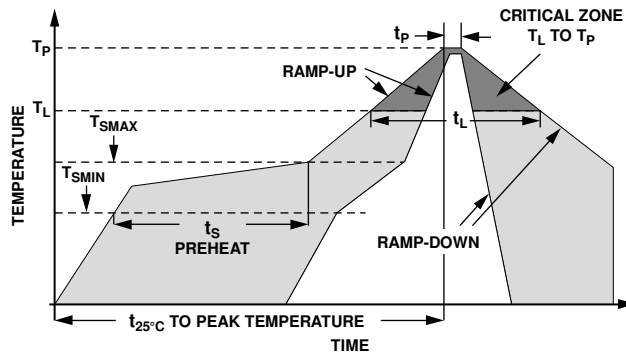

Figure 1. Recommended Soldering Profile Limits

TABLE 3. RECOMMENDED SOLDERING PROFILE\*

PROFILE FEATURE		Sn63/Pb37	Pb-Free
Average Ramp Rate ( $T_L$ to $T_P$ )		1.25°C/sec max	1.25°C/sec max
Preheat	Minimum Temperature ( $T_{SMIN}$ )	100°C	100°C
	Minimum Temperature ( $T_{SMIN}$ )	150°C	200°C
	Time ( $T_{SMIN}$ to $T_{SMAX}$ ), $t_S$	60 sec to 75 sec	60 sec to 75 sec
Ramp-Up Rate ( $T_{SMAX}$ to $T_L$ )		1.25°C/sec	1.25°C/sec
Time Maintained Above Liquidous ( $t_L$ )		45 sec to 75 sec	~50 sec
Liquidous Temperature ( $T_L$ )		183°C	217°C
Peak Temperature ( $T_P$ )		215°C +3°C/-3°C	260°C +0°C/-5°C
Time Within +5°C of Actual Peak Temperature ( $t_p$ )		20 sec to 30 sec	20 sec to 30 sec
Ramp-Down Rate		3°C/sec max	3°C/sec max
Time +25°C ( $t_{25^\circ\text{C}}$ ) to Peak Temperature		5 min max	5 min max

\*The reflow profile in Table 3 is recommended for board manufacturing with InvenSense MEMS microphones. All microphones are also compatible with the J-STD-020 profile.

**PIN CONFIGURATIONS AND FUNCTION DESCRIPTIONS**

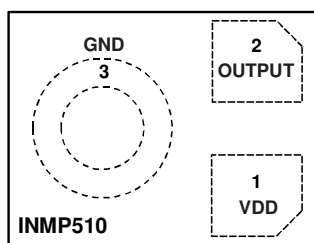

TOP VIEW  
(TERMINAL SIDE DOWN)  
Not to Scale

Figure 2. Pin Configuration

**TABLE 4. PIN FUNCTION DESCRIPTIONS**

PIN	NAME	FUNCTION
1	VDD	Power Supply
2	OUTPUT	Analog Output Signal
3	GND	Ground

**TYPICAL PERFORMANCE CHARACTERISTICS**

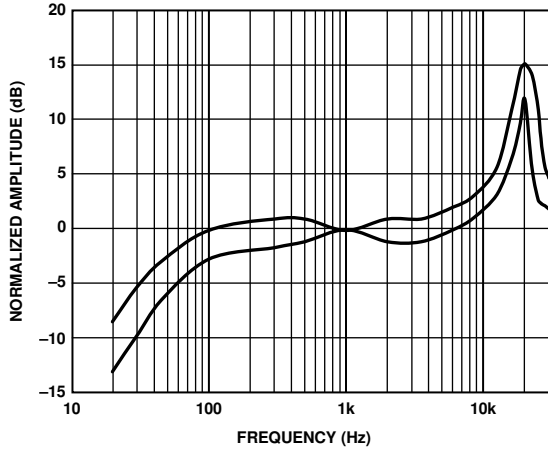

**Figure 3. Frequency Response Mask**

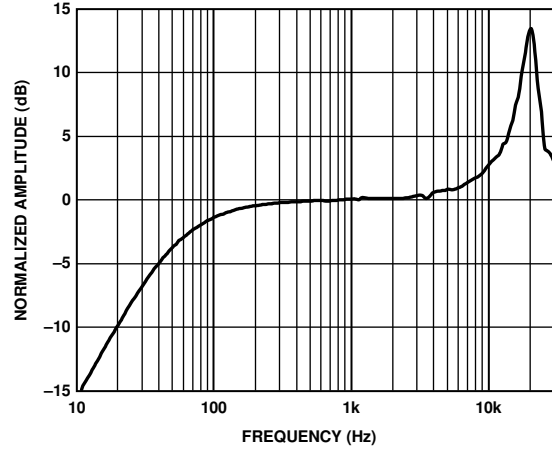

**Figure 4. Typical Frequency Response (Measured)**

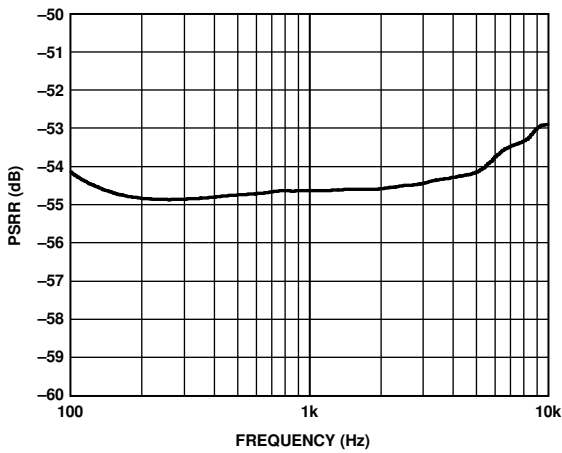

**Figure 5. PSR vs. Frequency, 100 mV p-p Swept Sine Wave**

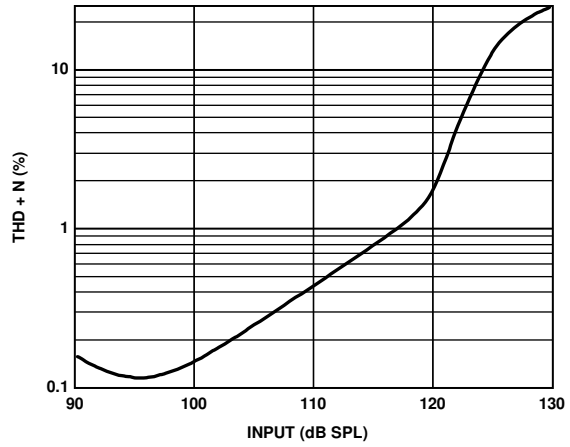

**Figure 6. Total Harmonic Distortion + Noise (THD+N) vs. Input SPL**

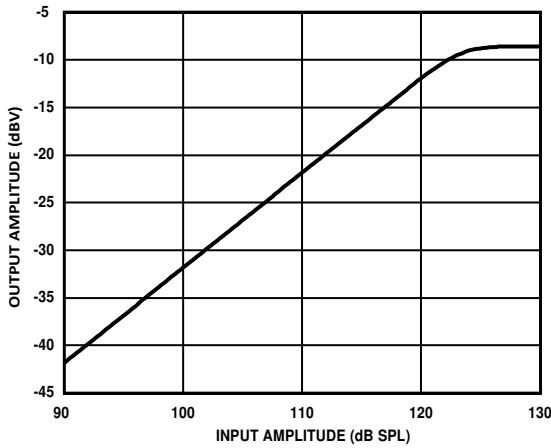

**Figure 7. Linearity**

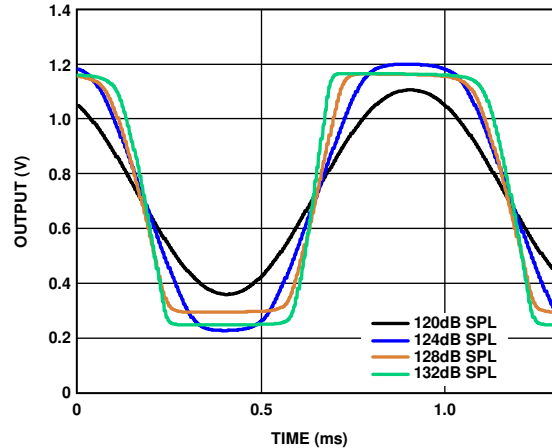

**Figure 8. Clipping Characteristics**

## APPLICATIONS INFORMATION

### CONNECTING TO AUDIO CODECS

The output of the INMP510 can be connected to a dedicated codec microphone input (see Figure 9) or to a high input impedance gain stage (see Figure 10). A 0.1  $\mu\text{F}$  ceramic capacitor placed close to the INMP510 supply pin is used for testing and is recommended to adequately decouple the microphone from noise on the power supply. A DC blocking capacitor is required at the output of the microphone. This capacitor creates a high-pass filter with a corner frequency at

$$f_c = 1/(2\pi \times C \times R)$$

where  $R$  is the input impedance of the codec.

A minimum value of 2.2  $\mu\text{F}$  is recommended in Figure 9 because the input impedance of codecs can be as low as 2  $\text{k}\Omega$  at their highest PGA gain setting, which results in a high-pass filter corner frequency at 37 Hz. Figure 10 shows the INMP510 connected to an op amp configured as a noninverting preamplifier.

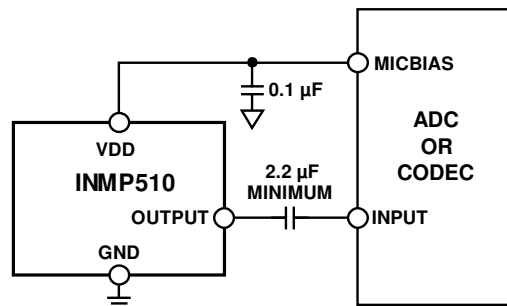

Figure 9. INMP510 Connected to a Codec

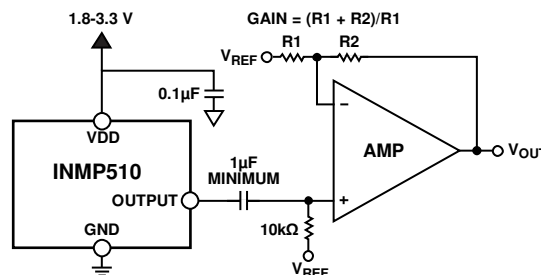

Figure 10. INMP510 Connected to an Op Amp



## **SUPPORTING DOCUMENTS**

For additional information, see the following documents.

### **EVALUATION BOARD USER GUIDE**

[UG-325](#) Analog Output MEMS Microphone Flex Evaluation Board

### **APPLICATION NOTES (GENERAL)**

[AN-1003](#) Recommendations for Mounting and Connecting the InvenSense, Bottom-Ported MEMS Microphones

[AN-1068](#) Reflow Soldering of the MEMS Microphone

[AN-1112](#) Microphone Specifications Explained

[AN-1124](#) Recommendations for Sealing InvenSense, Bottom-Port MEMS Microphones from Dust and Liquid Ingress

[AN-1140](#) Microphone Array Beamforming

[AN-1165](#) Op Amps for MEMS Microphone Preamp Circuits

[AN-1181](#) Using a MEMS Microphone in a 2-Wire Microphone Circuit

### **APPLICATION NOTES (PRODUCT SPECIFIC)**

[AN-0207](#) High-Performance Analog MEMS Microphone Simple Interface-to-SigmaDSP Audio Codec

[AN-0262](#) Low-Noise Analog MEMS Microphone and Preamp with Compression and Noise Gating

**PCB DESIGN AND LAND PATTERN LAYOUT**

The recommended PCB land pattern for the INMP504 should be laid out to a 1:1 ratio to the solder pads on the microphone package, as shown in Figure 8. Take care to avoid applying solder paste to the sound hole in the PCB. A suggested solder paste stencil pattern layout is shown in Figure 9. The diameter of the sound hole in the PCB should be larger than the diameter of the sound port of the microphone. A minimum diameter of 0.5 mm is recommended.

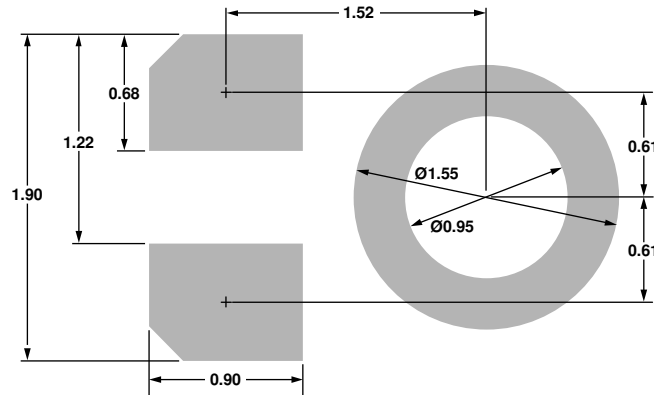

Dimensions shown in millimeters  
**Figure 11. PCB Land Pattern Layout**

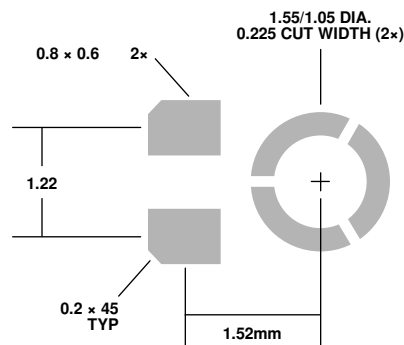

Dimensions shown in millimeters  
**Figure 12. Suggested Solder Paste Stencil Pattern Layout**

## **HANDLING INSTRUCTIONS**

### **PICK AND PLACE EQUIPMENT**

The MEMS microphone can be handled using standard pick-and-place and chip shooting equipment. Take care to avoid damage to the MEMS microphone structure as follows:

- Use a standard pickup tool to handle the microphone. Because the microphone hole is on the bottom of the package, the pickup tool can make contact with any part of the lid surface.
- Do not pick up the microphone with a vacuum tool that makes contact with the bottom side of the microphone. Do not pull air out of or blow air into the microphone port.
- Do not use excessive force to place the microphone on the PCB.

### **REFLOW SOLDER**

For best results, the soldering profile must be in accordance with the recommendations of the manufacturer of the solder paste used to attach the MEMS microphone to the PCB. It is recommended that the solder reflow profile not exceed the limit conditions specified in Figure 1 and Table 3.

### **BOARD WASH**

When washing the PCB, ensure that water does not make contact with the microphone port. Do not use blow-off procedures or ultrasonic cleaning.

OUTLINE DIMENSIONS

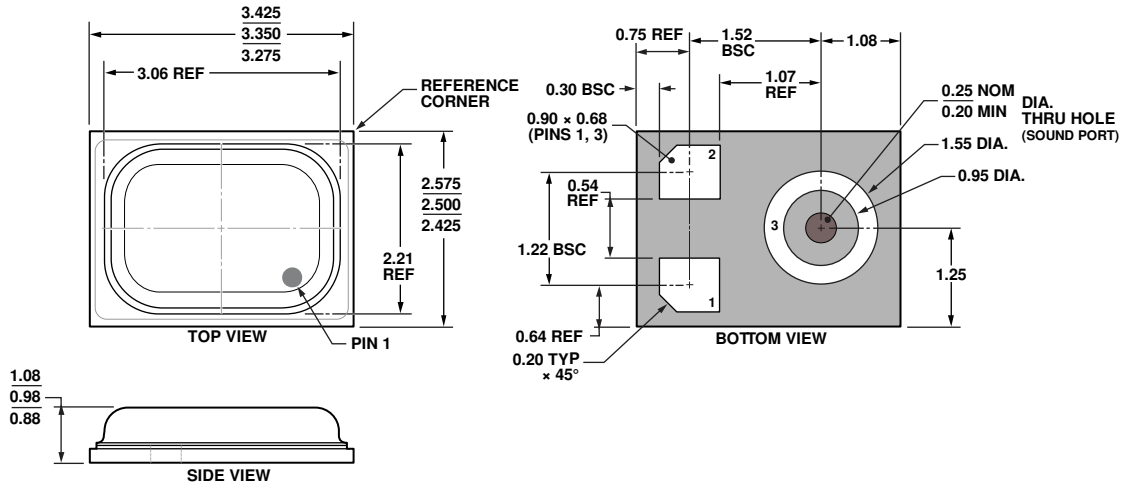

Figure 13. 3-Terminal Chip Array Small Outline No-Lead Cavity [LGA\_CAV]  
3.35 × 2.50 × 0.98 mm Body

Dimensions shown in millimeters

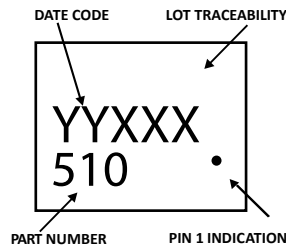

Figure 14. Package Marking Specification (Top View)

**ORDERING GUIDE**

PART	TEMP RANGE	PACKAGE	QUANTITY
INMP510ACEZ-R0 <sup>1*</sup>	-40°C to +85°C	3-Terminal LGA_CAV	10,000
INMP510ACEZ-R7 <sup>1†</sup>	-40°C to +85°C	3-Terminal LGA_CAV	1,000
EV_INMP510-FX	—	Flexible Evaluation Board	—

\* – 13” Tape and Reel

† – 7” Tape and reel is discontinued. Contact [sales@invensense.com](mailto:sales@invensense.com) for availability.

<sup>1</sup>Z = RoHS Compliant Part

**REVISION HISTORY**

REVISION DATE	REVISION	DESCRIPTION
02/06/2014	1.0	Initial Release
05/21/2014	1.1	Updated compliance disclaimer, replaced block diagram on page 1

**COMPLIANCE DECLARATION DISCLAIMER**

InvenSense believes the environmental and other compliance information given in this document to be correct but cannot guarantee accuracy or completeness. Conformity documents substantiating the specifications and component characteristics are on file. InvenSense subcontracts manufacturing and the information contained herein is based on data received from vendors and suppliers, which has not been validated by InvenSense.

This information furnished by InvenSense is believed to be accurate and reliable. However, no responsibility is assumed by InvenSense for its use, or for any infringements of patents or other rights of third parties that may result from its use. Specifications are subject to change without notice. InvenSense reserves the right to make changes to this product, including its circuits and software, in order to improve its design and/or performance, without prior notice. InvenSense makes no warranties, neither expressed nor implied, regarding the information and specifications contained in this document. InvenSense assumes no responsibility for any claims or damages arising from information contained in this document, or from the use of products and services detailed therein. This includes, but is not limited to, claims or damages based on the infringement of patents, copyrights, mask work and/or other intellectual property rights.

Certain intellectual property owned by InvenSense and described in this document is patent protected. No license is granted by implication or otherwise under any patent or patent rights of InvenSense. This publication supersedes and replaces all information previously supplied. Trademarks that are registered trademarks are the property of their respective companies. InvenSense sensors should not be used or sold in the development, storage, production or utilization of any conventional or mass-destructive weapons or for any other weapons or life threatening applications, as well as in any other life critical applications such as medical equipment, transportation, aerospace and nuclear instruments, undersea equipment, power plant equipment, disaster prevention and crime prevention equipment.

©2014 InvenSense, Inc. All rights reserved. InvenSense, MotionTracking, MotionProcessing, MotionProcessor, MotionFusion, MotionApps, DMP, AAR, and the InvenSense logo are trademarks of InvenSense, Inc. Other company and product names may be trademarks of the respective companies with which they are associated.



©2014 InvenSense, Inc. All rights reserved.