



MADE IN THE USA

Related Products (each sold separately):

- GB-001: Glove Box Dispenser - Single with Flexible Spring
- GB-002: Glove Box Dispenser - Double
- GB-003: Glove Box Dispenser - Triple (shown below)



Product Description:

- Glove Box Dispenser - Quad
- Holds four boxes of gloves
- Two-way keyholes for vertical or horizontal wall mounting
- White Powder-Coated Steel

Primary Area for Product Usage:

- Anywhere gloves are needed

Dispenses:

- Box(es) no larger than 5.25"W x 10.00"H x 3.75"D (13.3 cm x 25.4 cm x 9.5 cm)
- Box(es) no smaller than 4.25"W x 9.00"H x 2.77"D (10.8 cm x 22.9 cm x 7.0 cm)
- Any combination of box(es) no larger than 22.25"W x 10.00"H x 3.75"D (56.5 cm x 25.4 cm x 9.5 cm)

Package Specifications:

- Package Quantity: 4 per case
- 26"L x 11"W x 8"H (66.0 cm x 27.9 cm x 20.3 cm)
- 14.0 lbs (6.4 kg) - approximated

Product Specifications (overall external dimensions):

- 22.32"W x 10.00"H x 3.81"D (56.7 cm x 25.4 cm x 9.7 cm)
- 2.7 lbs (1.2 kg) - approximated

Mounting Specifications:

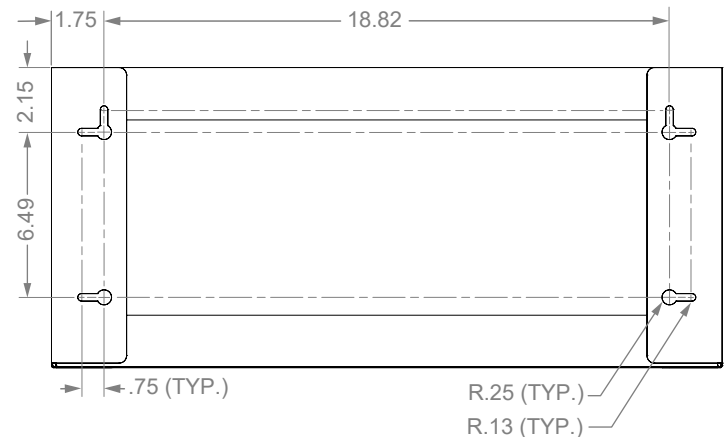



Installation

Always mount dispensers securely *prior* to loading with product.

- Open face design accommodates any dispensing perforations and is suitable for four glove boxes or a combination of sizes.

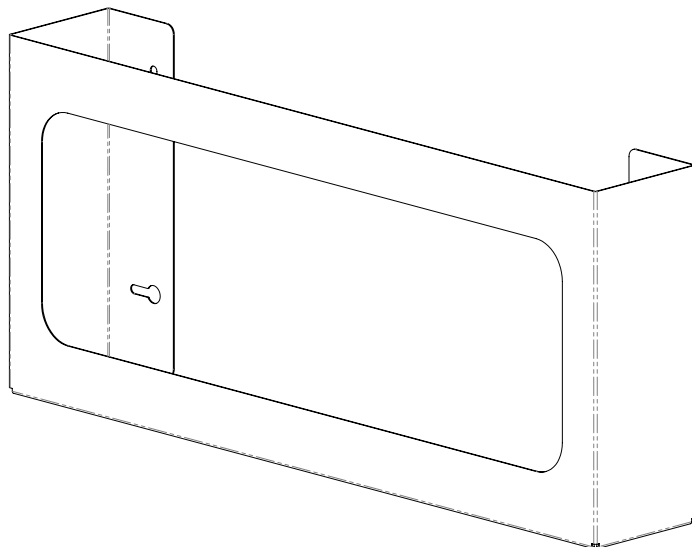

1

- Mount securely to a wall with screws approved and supplied by building maintenance.

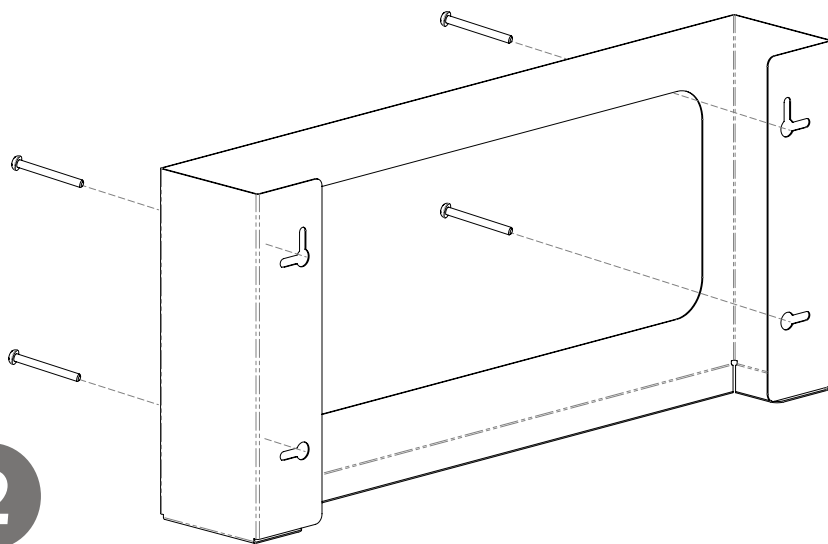

2

Parts included:

- Dispenser

Tools Required:

- No tools required to assemble dispenser

Care and Construction

Powder-Coated Steel

Material Characteristics

Designed for Long-Term Use

Our steel dispensers and stands are coated with polyester powders which makes them highly resistant to corrosion.

Powder-coated steel is ideal for dispensers used in a healthcare or an industrial setting because it is impact resistant and is not affected by extremes in temperature.

Dispensers and stands made of powder-coated steel are both attractive and functional, providing years of service.

Care and Cleaning

For best results, clean by washing the surface with a diluted solution of a mild, non-abrasive detergent in cold or warm water and a non-abrasive cloth. Standard hospital cleaning supplies can be used.

Dry with a soft cloth. Do not use any solvent-based materials, abrasives (e.g. Scotch-brite, steel wool), or apply excessive force during cleaning.