

LOC		DIST		P		ZONE		LTR		REVISIONS		DATE	APPC
AF	50									DESCRIPTION		JR	DB
										V	REV PER 061A-0150-99	EMAY99	

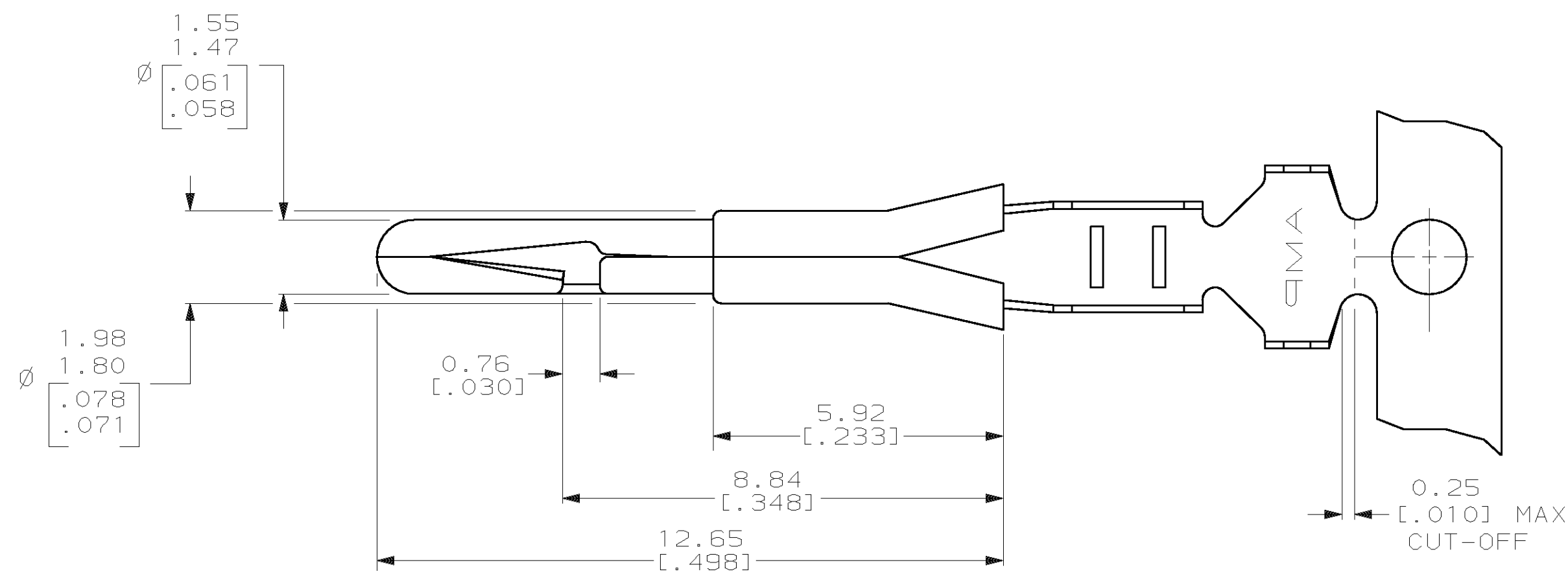

1. CONTINUOUS STRIP ON REELS.
2. INSULATION RANGE: \varnothing 1.52-2.79 [.060-.110].
WIRE RANGE: 0.3-0.9 mm² [22-18] AWG.
3. DIMENSIONS IN BRACKETS ARE IN INCHES.

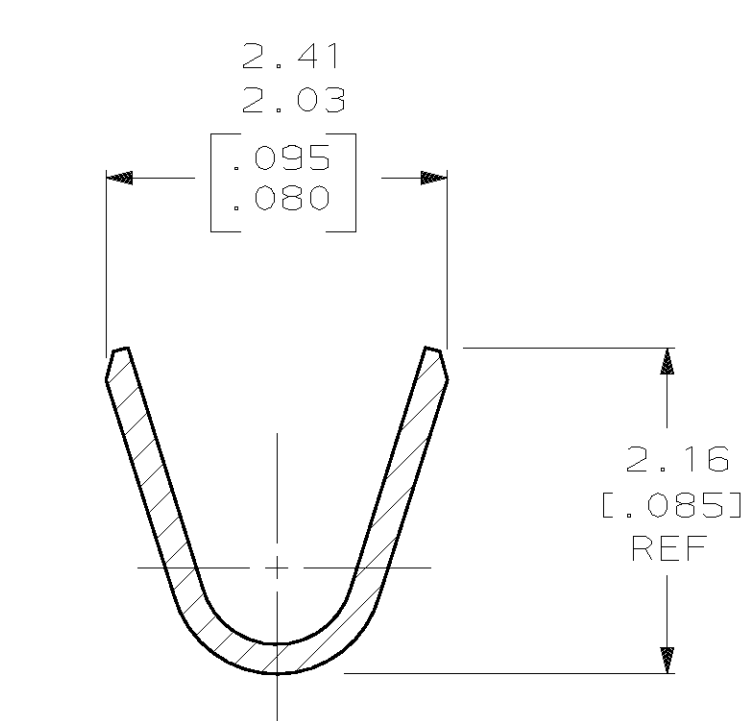
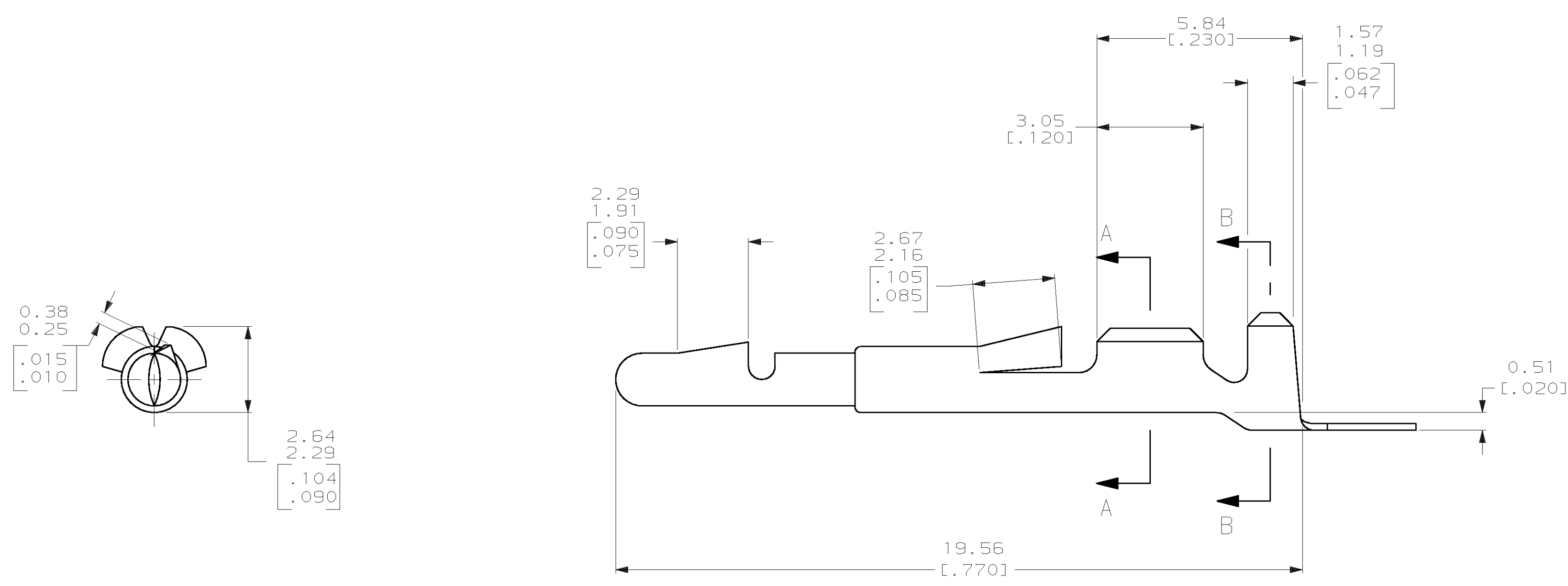

SECTION A-A
SCALE 20:1

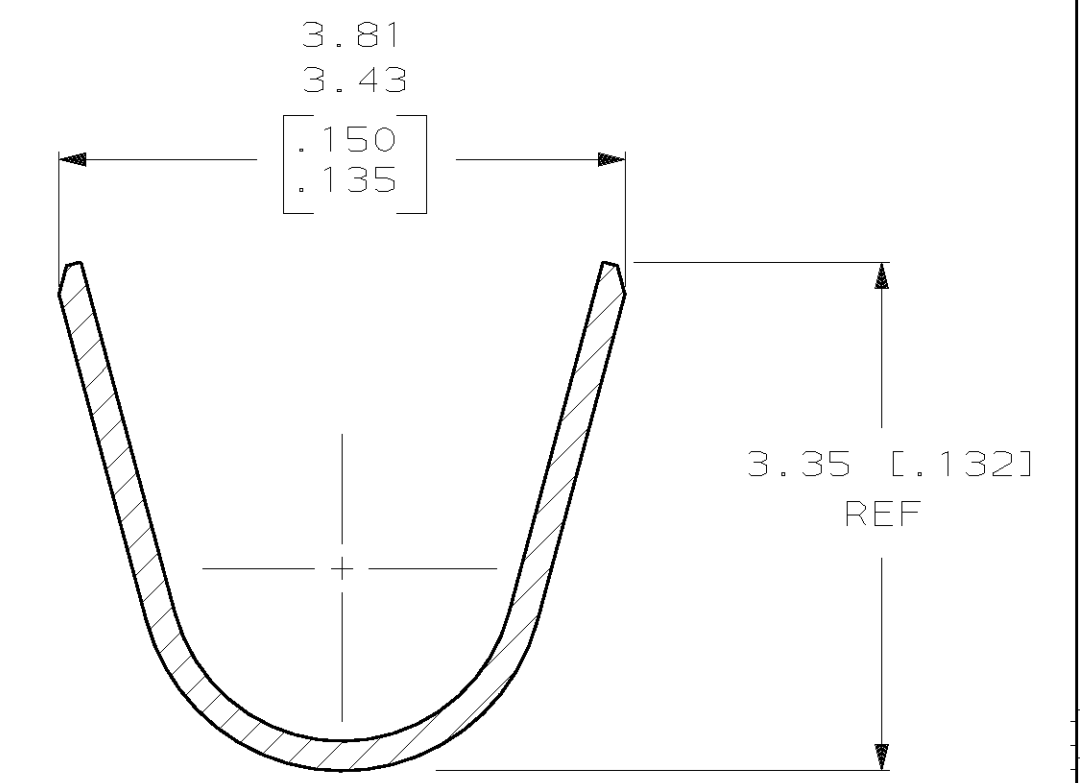

SECTION B-B
SCALE 20:1

61366-1
PART NUMBER

DO NOT SCALE PRINT. UNLESS SPECIFIED DIMENSIONS IN MM [INCHES] TOLERANCES ON: 2 PLC DEC \pm 0.13 (.005) 3 PLC DEC \pm - ANGLES \pm -		DR 6-26-90 B. LEWIS		AMP INCORPORATED Harrisburg, Pa. 17105	
MATERIAL 0.20 [.008] BRASS		CHK 6-26-90 R. SWING			
FINISH PRE-TIN		APPD 6-27-90 D. SELF		NAME PIN, .060 DIA, AUTOMOTIVE MATE-N-LOK TM	
APPLICATION SPEC -		APPD 6-26-90 D. SELF		DRAWING NO 61366	
WEIGHT -		SCALE 10:1		SHEET 1 OF 1	

METRIC