

Demonstration System EPC9510 Quick Start Guide

EPC2107 and EPC2036

6.78 MHz, ZVS Class-D Wireless Power Amplifier



DESCRIPTION

The EPC9510 is a high efficiency, Zero Voltage Switching (ZVS), class-D wireless power amplifier demonstration board that operates at 6.78 MHz (Lowest ISM band). The purpose of this demonstration system is to simplify the evaluation process of wireless power amplifier technology using eGaN® FETs by including all the critical components on a single board that can be easily connected into an existing system.

The amplifier board features the enhancement-mode half-bridge field effect transistor (FET), the 100 V rated EPC2107 eGaN FET with integrated synchronous bootstrap FET. The amplifier is configured for single ended operation and includes the gate driver/s, oscillator, and feedback controller for the pre-regulator that ensures operation for wireless power control based on the A4WP standard. This allows for testing compliant to the A4WP class 2 standard over a load range as high as $\pm 35j \Omega$. The pre-regulator features the 100 V rated 65 m Ω EPC2036 as the main switching device for a SEPIC converter.

For more information on the EPC2107 and EPC2036 eGaN FETs please refer to the datasheet available from EPC at www.epc-co.com. The datasheet should be read in conjunction with this quick start guide.

Table 1: Performance Summary (T_A = 25°C) EPC9510

Symbol	Parameter	Conditions	Min	Max	Units
V _{IN}	Bus Input Voltage Range – Pre-Regulator Mode	Also used in bypass mode for logic supply	17	24	V
V _{IN}	Amp Input Voltage Range – Bypass Mode		0	80	V
V _{OUT}	Switch Node Output Voltage			66	V
I _{OUT}	Switch Node Output Current (each)			0.8*	A
V _{extosc}	External Oscillator Input Threshold	Input 'Low'	-0.3	0.8	V
		Input 'High'	2.4	5	V
V _{Pre_Disable}	Pre-regulator Disable Voltage Range	Floating	-0.3	5.5	V
I _{Pre_Disable}	Pre-regulator Disable Current	Floating	-10	10	mA
V _{Osc_Disable}	Oscillator Disable Voltage Range	Open Drain/Collector	-0.3	5	V
I _{Osc_Disable}	Oscillator Disable Current	Open Drain/Collector	-25	25	mA
V _{SgnDiff}	Differential or Single Select Voltage	Open Drain/Collector	-0.3	5.5	V
I _{SgnDiff}	Differential or Single Select Current	Open Drain/Collector	-1	1	mA

* Maximum current depends on die temperature – actual maximum current will be subject to switching frequency, bus voltage and thermals.

DETAILED DESCRIPTION

Figure 1 shows the system block diagram of the EPC9510 ZVS class-D amplifier with pre-regulator and figure 2 shows the details of the ZVS class-D amplifier section. The pre-regulator is used to control the ZVS class-D wireless power amplifier based on three feedback parameters 1) the magnitude of the coil current indicated by the green LED, 2) the DC power drawn by the amplifier indicated by the yellow LED and 3) a maximum supply voltage to the amplifier indicated by the red LED. Only one parameter at any time is used to control the pre-regulator with the highest priority being the maximum voltage supplied to the amplifier followed by the power delivered to the amplifier and lastly the magnitude of the coil current. The maximum amplifier supply voltage is pre-set to 66 V and the maximum power drawn by the amplifier is pre-set to 10 W. The coil current magnitude is pre-set to 580 mA_{RMS} but can be made adjustable using P25. The pre-regulator comprises a SEPIC converter that can operate at full power from 17 V through 24 V.



EPC9510 Amplifier Board Photo

The pre-regulator can be bypassed by connecting the positive supply directly to the ZVS class-D amplifier supply after removing jumper JP1 at location JP1 and connecting the main positive supply to the bottom pin. JP1 can also be removed and replaced with a DC ammeter to directly measure the current drawn by the amplifier. When doing this observe a low impedance connection to ensure continued stable operation of the controller. Together with the Kelvin voltage probes (TP1 and TP2) connected to the amplifier supply, an accurate measurement of the power drawn by the amplifier can be made.

The EPC9510 is also provided with a miniature high efficiency switch-mode 5 V supply to power the logic circuits on board such as the gate drivers and oscillator.

The amplifier comes with its own low supply current oscillator that is pre-programmed to 6.78 MHz ± 678 Hz. It can be disabled by placing a jumper into JP70 or can be externally shutdown using an externally controlled open collector / drain transistor on the terminals of JP70 (note which is the ground connection). The switch needs to be capable of sinking at least 25 mA. An external oscillator can be used instead of the internal oscillator when connected to J70 (note which is the ground connection) and the jumper (JP71) is removed.

The pre-regulator can also be disabled in a similar manner as the oscillator using JP50. However, note that this connection is floating with respect to the ground so removing the jumper for external connection requires a floating switch to correctly control this function. Refer to the datasheet of the controller IC and the schematic in this QSG for specific details.

The EPC9510 is provided with 3 LED's that indicate the mode of operation of the system. If the system is operating in coil current limit mode, then the green LED will illuminate. For power limit mode, the yellow LED will illuminate. Finally, when the pre-regulator reaches maximum output voltage the red LED will illuminate indicating that the system is no longer A4WP compliant as the load impedance is too high for the amplifier to drive. When the load impedance is too high to reach power limit or voltage limit mode, then the current limit LED will illuminate incorrectly indicating current limit mode. This mode also falls outside the A4WP standard and by measuring the amplifier supply voltage across TP1 and TP2 will show that it has nearly reach the maximum value limit.

ZVS Timing Adjustment

Setting the correct time to establish ZVS transitions is critical to achieving high efficiency with the EPC9510 amplifier. This can be done by selecting the values for R71 and R72 or P71 and P72 respectively. This procedure is best performed using a potentiometer installed at the appropriate locations that is used to determine the fixed resistor values. The timing MUST initially be set WITHOUT the source coil connected to the amplifier. The timing diagrams are given in figure 5 and should be referenced when following this procedure. Only perform these steps if changes have been made to the board as it is shipped preset. The steps are:

1. With power off, remove the jumper in JP1 and install it into JP50 to place the EPC9510 amplifier into Bypass mode. Connect the main input power supply (+) to JP1 (bottom pin – for bypass mode) with ground connected to J1 ground (-) connection.

2. With power off, connect the control input power supply bus (19V) to (+) connector J1. Note the polarity of the supply connector.

3. Connect a LOW capacitance oscilloscope probe to the probe-hole of the half-bridge to be set and lean against the ground post as shown in figure 4.

4. Turn on the control supply – make sure the supply is approximately 19V.

5. Turn on the main supply voltage starting at 0 V and increasing to the required predominant operating value (such as 24 V but NEVER exceed the absolute maximum voltage of 66 V).

6. While observing the oscilloscope adjust the applicable potentiometers to so achieve the green waveform of figure 5.

7. Replace the potentiometers with fixed value resistors if required. Remove the jumper from JP50 and install it back into JP1 to revert the EPC9510 back to pre-regulator mode.

Determining component values for L_{ZVS}

The ZVS tank circuit is not operated at resonance, and only provides the necessary negative device current for self-commutation of the output voltage at turn off. The capacitor C_{ZVS1} is chosen to have a very small ripple voltage component and is typically around 1 μF. The amplifier supply voltage, switch-node transition time will determine the value of inductances for L_{ZVS1} and L_{ZVS2} which needs to be sufficient to maintain ZVS operation over the DC device load resistance range and coupling between the device and source coil range and can be calculated using the following equation:

$$L_{ZVS} = \frac{\Delta t_{vt}}{8 \cdot f_{sw} \cdot C_{OSSQ} + C_{well}} \quad (1)$$

Where:

Δt_{vt} = Voltage transition time [s]

f_{sw} = Operating frequency [Hz]

C_{OSSQ} = Charge equivalent device output capacitance [F].

C_{well} = Gate driver well capacitance [F]. Use 20 pF for the LM5113

NOTE. the amplifier supply voltage V_{AMP} is absent from the equation as it is accounted for by the voltage transition time. The C_{OSS} of the EPC2107 eGaN FETs is very low and lower than the gate driver well capacitance C_{well} which as a result must now be included in the ZVS timing calculation. The charge equivalent capacitance can be determined using the following equation:

$$C_{OSSQ} = \frac{1}{V_{AMP}} \cdot \int_0^{V_{AMP}} C_{OSS}(v) \cdot dv \quad (2)$$

To add additional immunity margin for shifts in coil impedance, the value of L_{ZVS} can be decreased to increase the current at turn off of the devices (which will increase device losses). Typical voltage transition times range from 2 ns through 12 ns.

QUICK START PROCEDURE

The EPC9510 amplifier board is easy to set up and evaluate the performance of the eGaN FET in a wireless power transfer application.

The EPC9510 can be operated using any one of two alternative methods:

- a. Using the pre-regulator.
- b. Bypassing the pre-regulator.

a. Operation using the pre-regulator

The pre-regulator is used to supply power to the amplifier in this mode and will limit the coil current, power delivered or maximum supply voltage to the amplifier based on the pre-determined settings.

The main 19 V supply must be capable of delivering 2 ADC. DO NOT turn up the voltage of this supply when instructed to power up the board, instead simply turn on the supply. The EPC9510 board includes a pre-regulator to ensure proper operation of the board including start up.

1. Make sure the entire system is fully assembled prior to making electrical connections and make sure jumper JP1 is installed. Also make sure the source coil and device coil with load are connected.
2. With power off, connect the main input power supply bus to J1 as shown in figure 3. Note the polarity of the supply connector.
3. Make sure all instrumentation is connected to the system.
4. Turn on the main supply voltage to the required value (19 V).
5. Once operation has been confirmed, observe the output voltage, efficiency and other parameters on both the amplifier and device boards.
6. For shutdown, please follow steps in the reverse order.

b. Operation bypassing the pre-regulator

In this mode, the pre-regulator is bypassed and the main power is connected directly to the amplifier. This allows the amplifier to be operated using an external regulator. In this mode there is no protection for ensuring the correct operating conditions for the eGaN FETs.

1. Make sure the entire system is fully assembled prior to making electrical connections and make sure jumper JP1 has been removed and installed in JP50 to disable the pre-regulator and place the EPC9510 in bypass mode. Also make sure the source coil and device coil with load are connected.
2. With power off, connect the main input power supply bus to the bottom pin of JP1 and the ground to the ground connection of J1 as shown in figure 3.

3. With power off, connect the control input power supply bus to J1. Note the polarity of the supply connector. This is used to power the gate drivers and logic circuits.
4. Make sure all instrumentation is connected to the system.
5. Turn on the control supply – make sure the supply is 19 V range.
6. Turn on the main supply voltage to the required value (it is recommended to start at 0 V and do not exceed the absolute maximum voltage of 80 V).
7. Once operation has been confirmed, adjust the main supply voltage within the operating range and observe the output voltage, efficiency and other parameters on both the amplifier and device boards.
8. For shutdown, please follow steps in the reverse order. Start by reducing the main supply voltage to 0 V followed by steps 6 through 2.

NOTE.

1. When measuring the high frequency content switch-node (Source Coil Voltage), care must be taken to avoid long ground leads. An oscilloscope probe connection (preferred method) has been built into the board to simplify the measurement of the Source Coil Voltage (shown in figure 4).
2. AVOID using a Lab Benchtop programmable DC as the load for the device board. These loads have low control bandwidth and will cause the EPC9510 system to oscillate at a low frequency and may lead to failure. It is recommended to use a fixed low inductance resistor as an initial load. Once a design matures, a post regulator, such as a Buck converter, can be used.

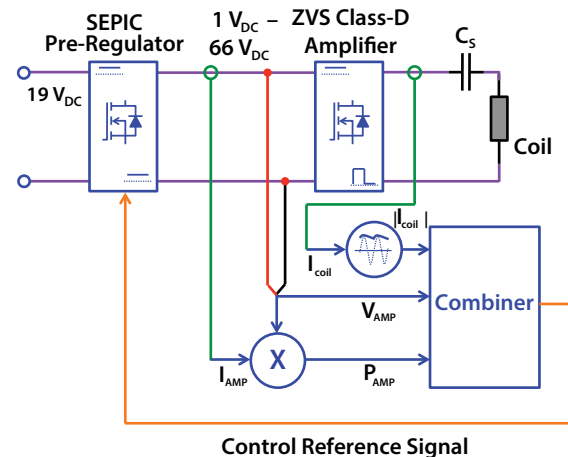

Figure 1: Block diagram of the EPC9510 wireless power amplifier

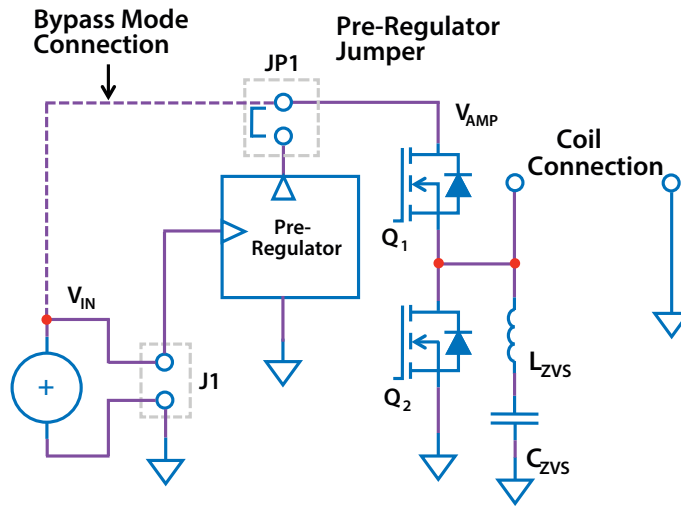

Figure 2: Diagram of EPC9510 Amplifier Circuit

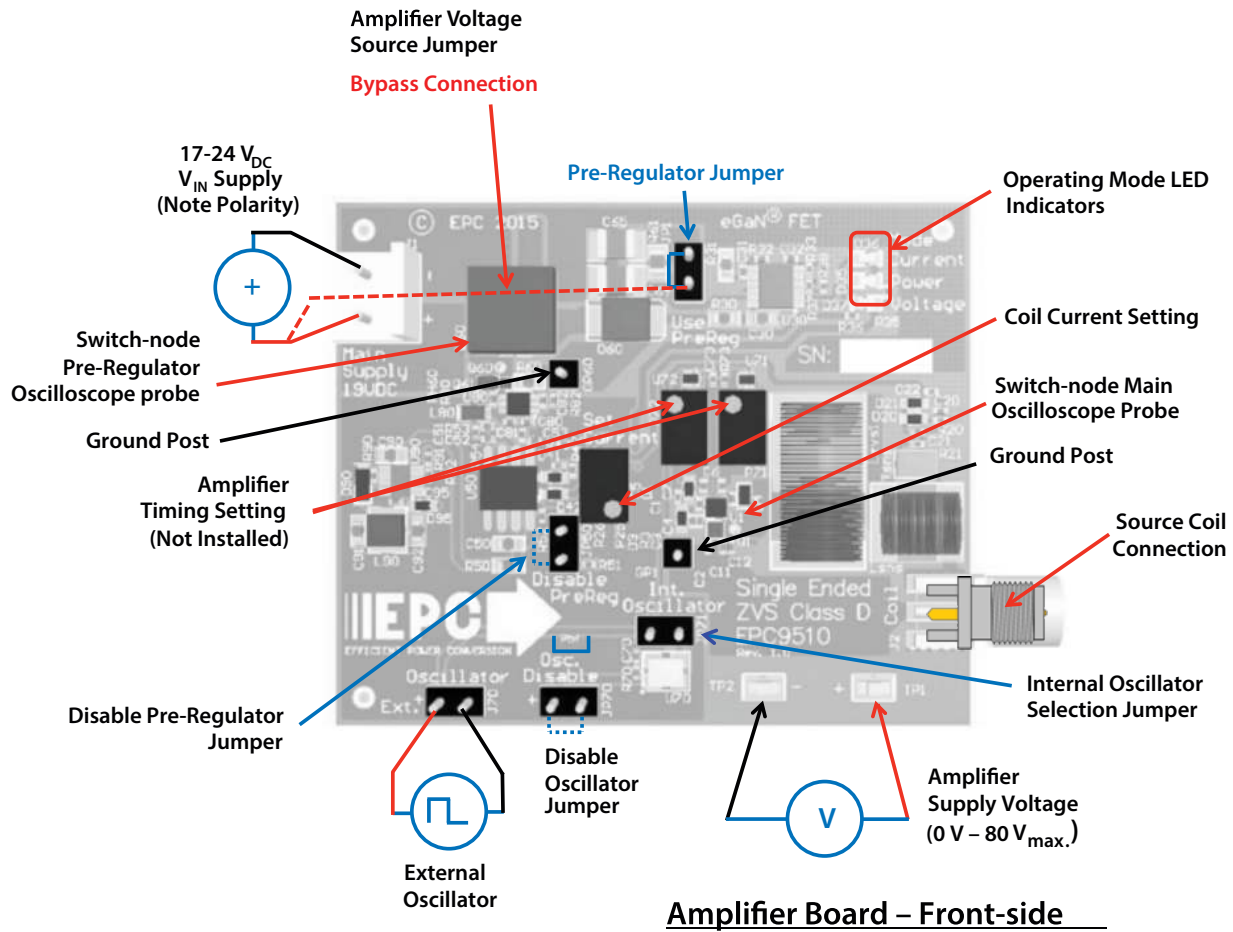

Figure 3: Proper Connection and Measurement Setup for the Amplifier Board

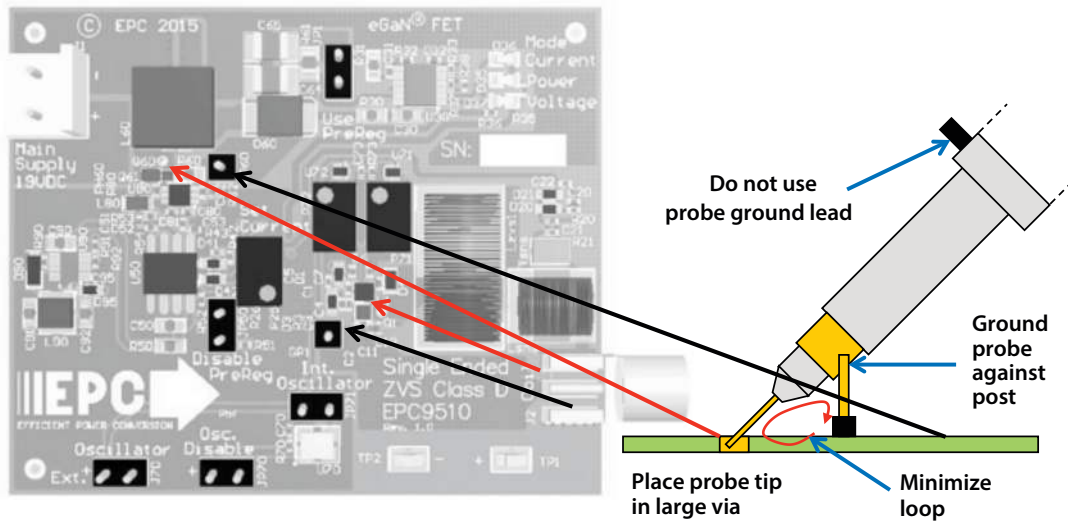

Figure 4: Proper Measurement of the Switch Nodes using the hole and ground post

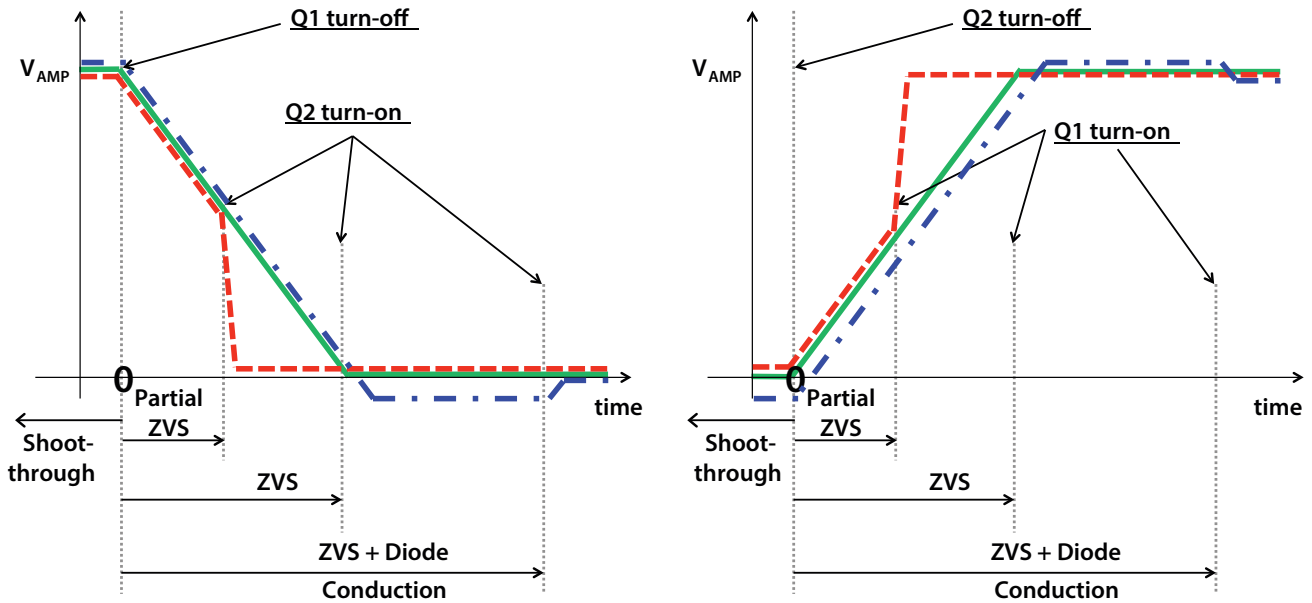

Figure 5: ZVS Timing Diagrams

THERMAL CONSIDERATIONS

The EPC9510 demonstration system showcases the EPC2107 and EPC2036 eGaN FETs in a wireless energy transfer application. Although the electrical performance surpasses that of traditional silicon devices, their relatively smaller size does magnify the thermal management requirements. The operator must observe the temperature of the gate driver and eGaN FETs to ensure that both are operating within the thermal limits as per the datasheets

NOTE. The EPC9510 demonstration system has limited current protection only when operating off the Pre-Regulator. When bypassing the pre-regulator there is no current protection on board and care must be exercised not to over-current or over-temperature the devices. Excessively wide coil coupling and load range variations can lead to increased losses in the devices.

Pre-Cautions

The EPC9510 demonstration system has a limited controller and no enhanced protection systems and therefore should be operated with caution. Some specific precautions are:

1. Please contact EPC at info@epc-co.com should the tuning of the coil be required to change to suit specific conditions so that it can be correctly adjusted for use with the ZVS class-D amplifier.
2. There is no heat-sink on the devices and during experimental evaluation it is possible present conditions to the amplifier that may cause the devices to overheat. Always check operating conditions and monitor the temperature of the EPC devices using an IR camera.
3. Never connect the EPC9510 amplifier board into your VNA in an attempt to measure the output impedance of the amplifier. Doing so will severely damage the VNA.

Table 2: Bill of Materials - Amplifier Board

Item	Qty	Reference	Part Description	Manufacturer	Part #
1	2	C1, C80	1 μ F, 10 V	TDK	C1005X751A105M050BC
2	8	C2, C4, C51, C70, C71, C72, C81, C130	100 nF, 16 V	Würth	885012205037
3	2	C3, C95	22 nF, 25 V	Würth	885012205052
4	1	C5	DNP (100 nF, 16 V)	Würth	885012205037
5	1	C20	DNP (10 nF, 50 V)	Murata	GRM155R71H103KA88D
6	1	C45	DNP (10 nF, 100 V)	Murata	C1005X752A103K050BB
7	1	C73	DNP (22 pF, 50 V)	Würth	
8	1	C133	DNP (1 nF, 50 V)	Murata	
9	1	R20	DNP (10k)	Panasonic	ERJ-2GEJ103X
10	1	R45	DNP (1.5k)	Panasonic	ERJ-2RKF1501X
11	5	C6, C7, C31, C44, C82	22 pF, 50 V	Würth	885012005057
12	2	C11, C12	10 nF, 100 V	TDK	C1005X752A103K050BB
13	3	C15, C64, C65	2.2 μ F, 100 V	Taiyo Yuden	HMK325B7225KN-T
14	1	C21	680 pF, 50 V	Murata	GRM155R71H681KA01D
15	1	C22	1 nF, 50 V	Murata	GRM155R71H102KA01D
16	2	C30, C50	100 nF, 100 V	Murata	GRM188R72A104KA35D
17	1	C32	47 nF, 25 V	Murata	GRM155R71E473KA88D
18	2	C43, C53	10 nF, 50 V	Murata	GRM155R71H103KA88D
19	1	C52	100 pF	Murata	GRM1555C1H101JA01D
20	2	C61, C62	4.7 μ F, 50 V	Taiyo Yuden	UMK325BJ475MM-T
21	1	C63	10 μ F, 35 V	Taiyo Yuden	GMK325BJ106KN-T
22	3	C90, C91, C92	1 μ F, 25 V	Würth	885012206076
23	1	C131	1 nF, 50 V	Murata	GRM1555C1H102JA01D
24	1	Czvs1	1 μ F, 50 V	Würth	885012207103
25	2	D1, D95	40 V, 300 mA	ST	BAT54KFLM
26	7	D2, D21, D40, D41, D42, D71, D72	40 V, 30 mA	Diodes Inc.	SDM03U40
27	2	D3, D20	DNP (40 V, 30 mA)	Diodes Inc.	SDM03U40
28	1	D4	5V1, 150 mW	Bournes	CD0603-Z5V1
29	1	D35	LED 0603 Yellow	Lite-On	LTST-C193KSKT-5A
30	1	D36	LED 0603 Green	Lite-On	LTST-C193KGKT-5A
31	1	D37	LED 0603 Red	Lite-On	LTST-C193KRKT-5A
32	1	D60	100 V, 1A	On-Semi	MBRS1100T3G
33	1	D90	40 V, 1A	Diodes Inc.	PD3S140-7
34	2	GP1, GP60	.1" mAle Vert.	Würth	61300111121
35	1	J1	.156" mAle Vert.	Würth	645002114822
36	1	J2	SMA Board Edge	Linx	CONSAM003.61
37	5	J70, JP1, JP50, JP70, JP71	.1" mAle Vert.	Würth	61300211121
38	1	L60	100 μ H, 2.2A	CoilCraft	MSD1260-104ML

(continued on next page)

Table 2: Bill of Materials - Amplifier Board (continued)

Item	Qty	Reference	Part Description	Manufacturer	Part #
39	1	L80	10 μ H, 150 mA	Taiyo Yuden	LBR2012T100K
40	1	L90	47 μ H, 250 mA	Würth	7440329470
41	1	Lsns	110 nH	CoilCraft	22225Q-111JE
42	2	Lzvs1, Lzvs2	390 nH	CoilCraft	29295Q-391JE
43	1	P25	DNP (10k)	Murata	PV37Y103C01B00
44	2	P71, P72	DNP (1k)	Murata	PV37Y102C01B00
45	1	Q1	100 V, 220 m Ω with SB	EPC	EPC2107
46	1	Q60	100 V, 65 m Ω	EPC	EPC2036
47	1	Q61	DNP (100 V, 6A, 30m Ω)	EPC	EPC2007C
48	2	R2, R82	20 Ω	Stackpole	RMCF0402JT20R0
49	1	R3	27 k	Panasonic	ERJ-2GEJ273X
50	1	R4	4.7 Ω	Panasonic	ERJ-2GEJ4R7X
51	1	R21	100k	Panasonic	ERJ-2GEJ104X
52	2	R25, R133	6.8k, 1%	Panasonic	ERJ-2RKF6801X
53	1	R26	2.8k, 1%	Panasonic	ERJ-2RKF2801X
54	1	R30	100 Ω	Panasonic	ERJ-3EKF1000V
55	1	R31	71k5, 1%	Panasonic	ERJ-6ENF7152V
56	1	R32	8.2k, 1%	Panasonic	ERJ-2RKF8201X
57	1	R33	75k	Panasonic	ERJ-2GEJ753X
58	2	R35, R36	634 Ω	Panasonic	ERJ-2RKF6340X
59	1	R37	150k, 1%	Panasonic	ERJ-2RKF1503X
60	2	R38, R91	49.9k, 1%	Panasonic	ERJ-2RKF4992X
61	2	R40, R130	261k	Panasonic	ERJ-3EKF2613V
62	2	R41, R131	6.04k	Panasonic	ERJ-2RKF6041X
63	1	R42	24.9k	Panasonic	ERJ-2RKF2492X
64	1	R43	10.5k	Panasonic	ERJ-2RKF1052X
65	2	R44, R90	100k, 1%	Panasonic	ERJ-2RKF1003X
66	1	R50	10 Ω	Panasonic	ERJ-3EKF10R0V
67	1	R51	124k, 1%	Panasonic	ERJ-2RKF1243X
68	1	R52	71.5k, 1%	Panasonic	ERJ-2RKF7152X
69	1	R53	1.00k	Panasonic	ERJ-2RKF1001X
70	1	R54	0 Ω	Yageo	RC0402JR-070RL
71	1	R60	80 m Ω , 0.4 W	Vishay Dale	WSP0603R0800FEB
72	1	R61	300 m Ω , 0.125 W	Vishay Dale	RL0805FR-070R3L
73	1	R70	47k	Panasonic	ERJ-2RKF4702X
74	1	R71	430 Ω	Panasonic	ERJ-2RKF4300X
75	1	R72	180 Ω	Panasonic	ERJ-2RKF1800X
76	1	R73	10k	Panasonic	ERJ-2GEJ103X
77	1	R80	2.2 Ω	Yageo	RC0402JR-072R2L
78	1	R92	9.53k 1%	Panasonic	ERJ-2RKF9531X
79	1	R132	18k 1%	Panasonic	ERJ-2RKF1802X
80	1	R134	470k	Panasonic	ERJ-2RKF4703X
81	2	TP1, TP2	SMD Probe Loop	Keystone	5015
82	1	Tsns	10 μ H, 1:1, 96.9%	CoilCraft	PF3215-103ME
83	1	U1	100 V, eGaN Driver	National Semiconductor	LM5113TM
84	1	U30	Power & Current Monitor	Linear	LT2940IMS#PBF
85	1	U50	Boost Controller	Texas Instruments	LM3478MAG/NOPB
86	1	U70	Programmable Oscillator	KDS Daishinku America	DSO221SHF 6.780
87	1	U71	2 In NAND	Fairchild	NC7SZ00L6X
88	1	U72	2 In AND	Fairchild	NC7SZ08L6X
89	1	U80	Gate Driver with LDO	Texas Instruments	UCC27611DRV
90	1	U90	1.4 MHz, 24 V, 0.5 A Buck	MPS	MP2357DJ-LF
91	1	U130	Comparator	Texas Instruments	TLV3201AIDBVR

EPC would like to acknowledge Würth Electronics (www.we-online.com/web/en/wuerth_elektronik/start.php), Coilcraft (www.coilcraft.com), and KDS Daishinku America (www.kdsamerica.com) for their support of this project.

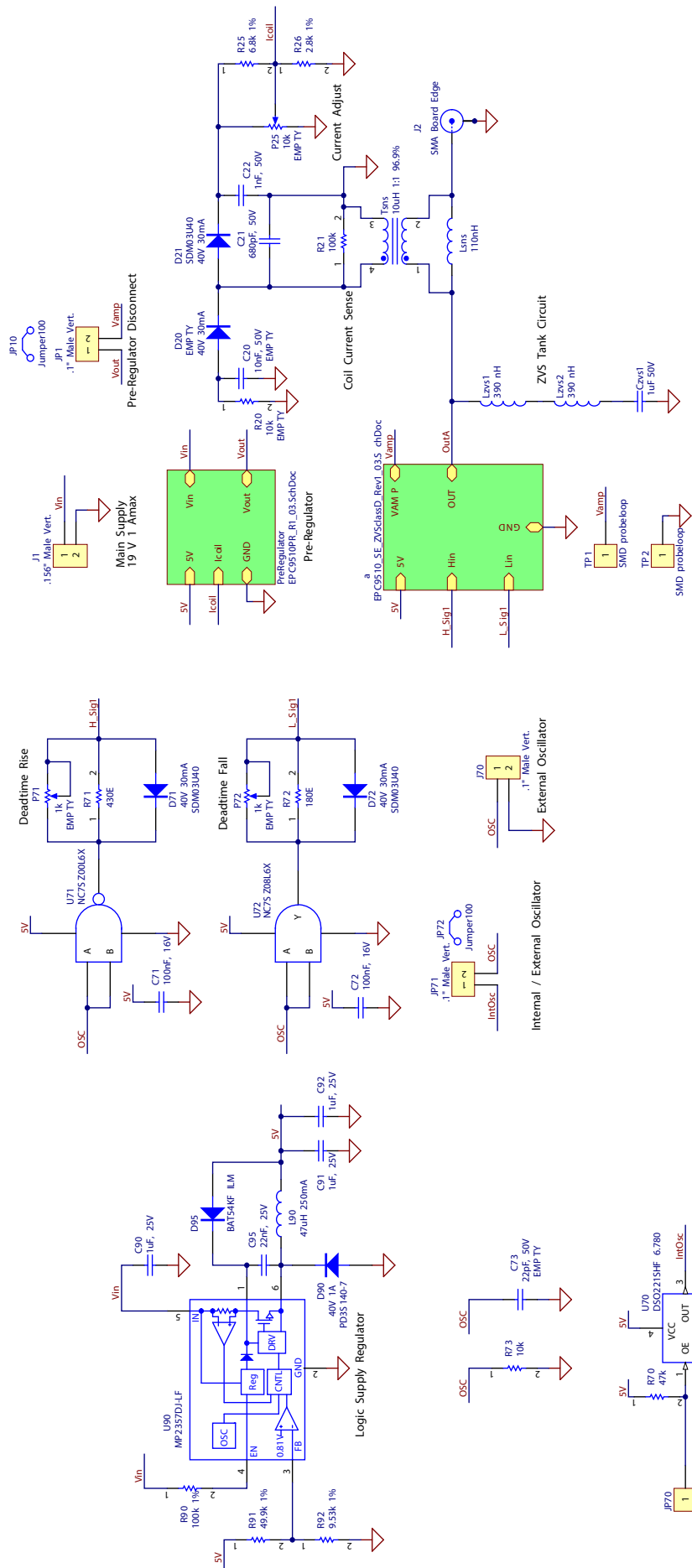

Figure 6: EPC9510-ZVS Class-D Schematic

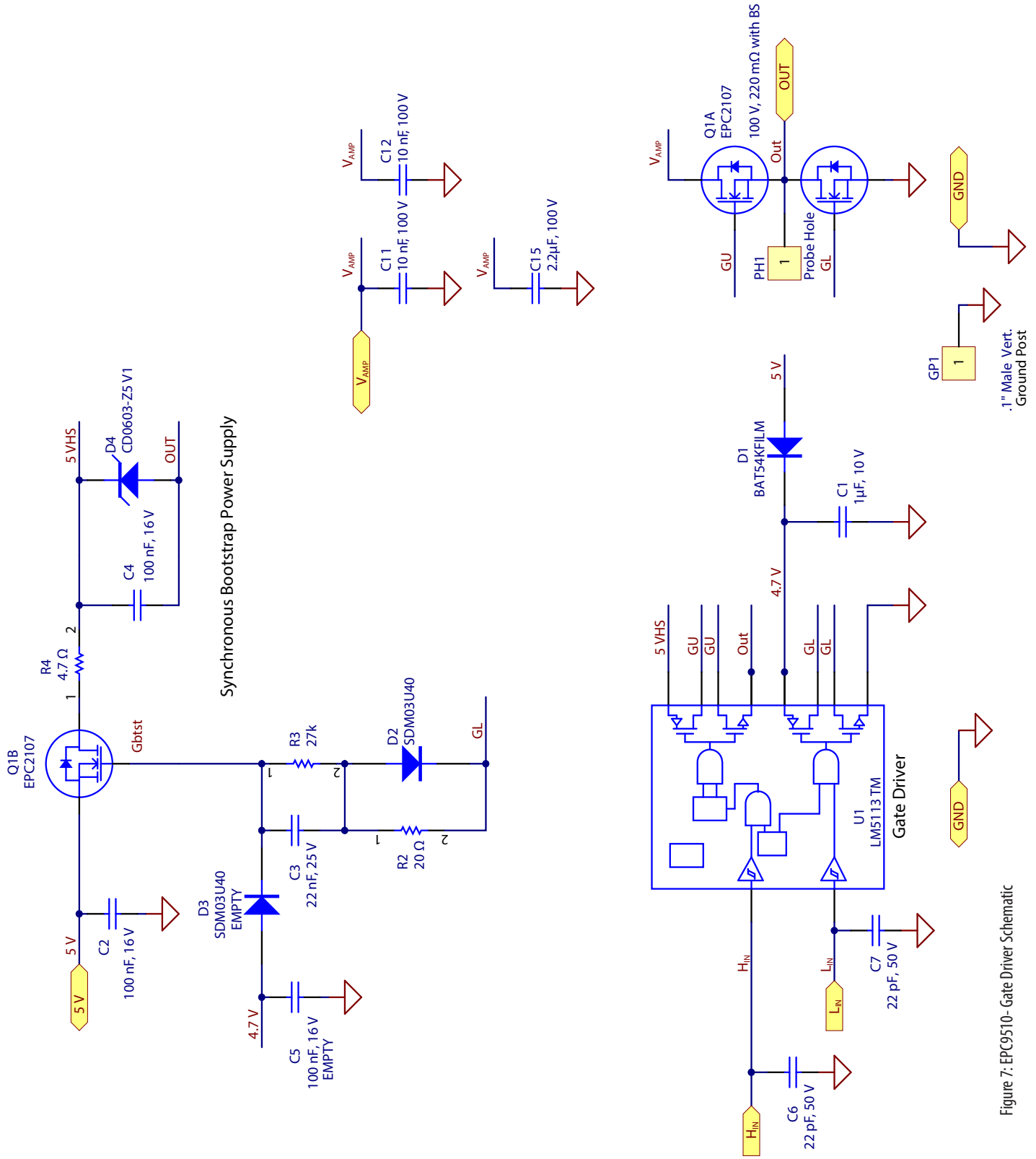

Figure 7: EPC9510 - Gate Driver Schematic

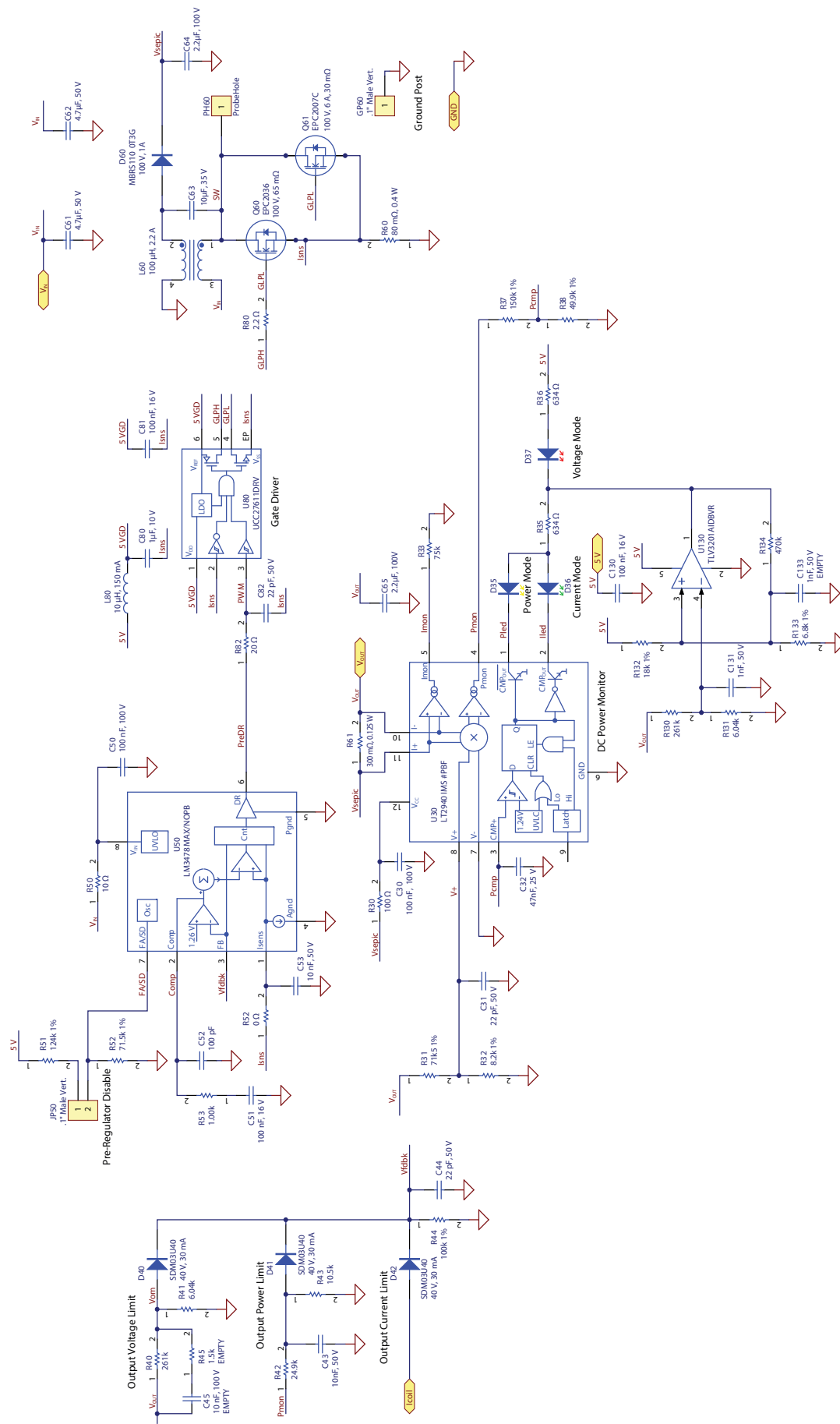

Figure 8: EPC9510 Pre-Regulator Schematic

For More Information:

Please contact info@epc-co.com
or your local sales representative

Visit our website:
www.epc-co.com

Sign-up to receive
EPC updates at
bit.ly/EPCupdates
or text "EPC" to 22828



EPC Products are distributed through Digi-Key.
www.digikey.com

Demonstration Board Notification

The EPC9510 board is intended for product evaluation purposes only and is not intended for commercial use. Replace components on the Evaluation Board only with those parts shown on the parts list (or Bill of Materials) in the Quick Start Guide. Contact an authorized EPC representative with any questions.

This board is intended to be used by certified professionals, in a lab environment, following proper safety procedures. Use at your own risk.

As an evaluation tool, this board is not designed for compliance with the European Union directive on electromagnetic compatibility or any other such directives or regulations. As board builds are at times subject to product availability, it is possible that boards may contain components or assembly materials that are not RoHS compliant. Efficient Power Conversion Corporation (EPC) makes no guarantee that the purchased board is 100% RoHS compliant.

The Evaluation board (or kit) is for demonstration purposes only and neither the Board nor this Quick Start Guide constitute a sales contract or create any kind of warranty, whether express or implied, as to the applications or products involved.

Disclaimer: EPC reserves the right at any time, without notice, to make changes to any products described herein to improve reliability, function, or design. EPC does not assume any liability arising out of the application or use of any product or circuit described herein; neither does it convey any license under its patent rights, or other intellectual property whatsoever, nor the rights of others.