

THIS DRAWING IS UNPUBLISHED. RELEASED FOR PUBLICATION - N/A .  
 © COPYRIGHT N/A BY TYCO ELECTRONICS CORPORATION. ALL RIGHTS RESERVED.

LOC	DIST	REVISIONS			
P	LTR	DESCRIPTION	DATE	DWN	APVD
DF	XO	A	RELEASED	6-22-05	CT FB

COMPONENT	MATERIAL	FINISH
HOUSING MOUNTING NUT LOCKWASHER	STAINLESS STEEL PER ASTM-A484 AND ASTM-A582, TYPE 303	PASSIVATE PER ASTM-A-380
DIELECTRIC	TFE FLUOROCARBON PER ASTM-D-1457	N/A
CENTER CONTACT	BERYLLIUM COPPER PER ASTM-B-196 OR ASTM-B-197, ALLOY C17300, CONDITION H	GOLD PLATE PER ASTM-B-488
O-RING	FLOUROSILICONE PER MIL-R-25988, CLASS I, TYPE I.	N/A

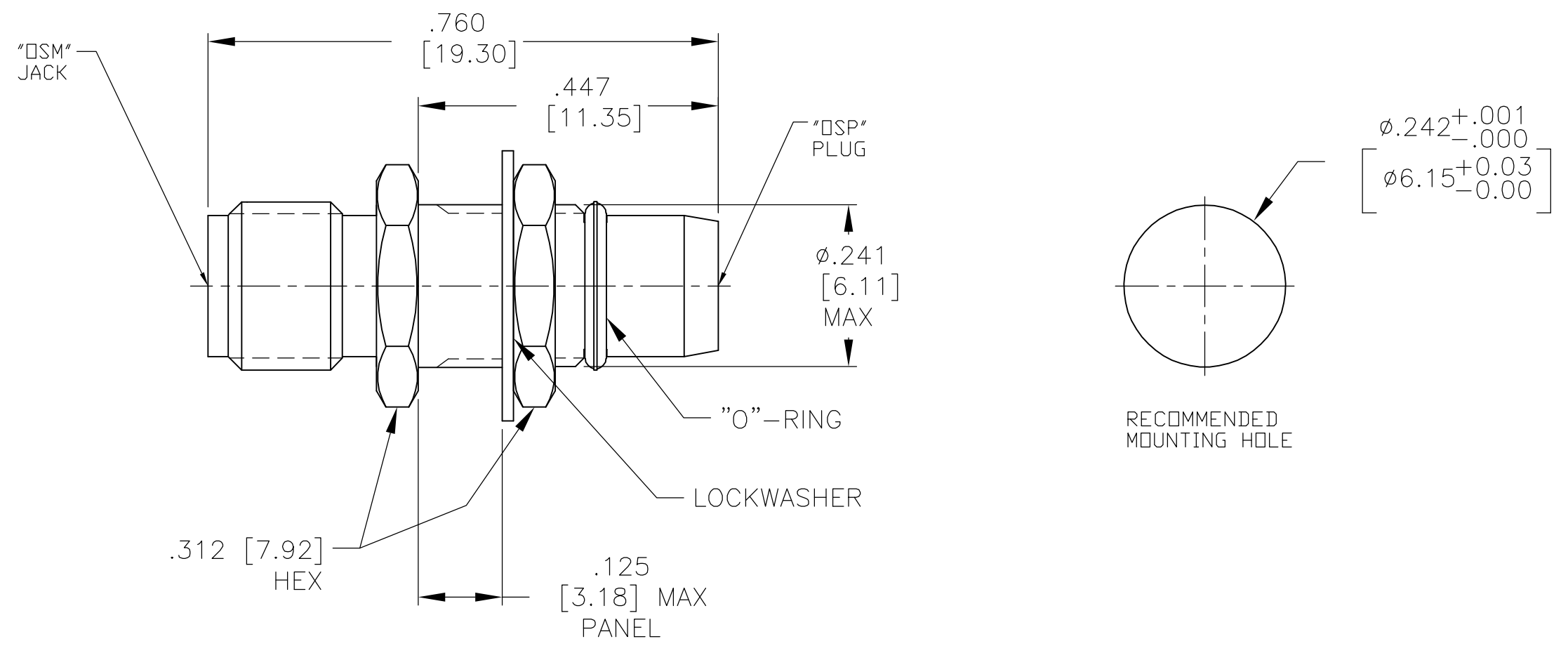

1. CAPTURED CENTER CONTACT
2. FREQUENCY RANGE (GHz): DC TO 18 GHz
3. VSWR: 1.05+, .005f(GHz)
4. INSERTION LOSS: (dB MAX): 0.6 √f(GHz)

1757459-1  
 PART NUMBER

THIS DRAWING IS A CONTROLLED DOCUMENT.		DWN C.C.THOMAS 6-22-05	<b>AMP</b> Tyco Electronics Corporation Harrisburg, Pa 17105-3608	
DIMENSIONS: INCHES [mm]		CHK F.BLASICK 6-22-05		
		APVD F.BLASICK 6-22-05	NAME OSM JACK TO OSP BULKHEAD FEED-THRU PLUG ADAPTER	
TOLERANCES UNLESS OTHERWISE SPECIFIED:		PRODUCT SPEC	APPLICATION SPEC	
0 PLC ± - 1 PLC ± - 2 PLC ± - 3 PLC ± .005 [0.13] 4 PLC ± - ANGLES ± -		WEIGHT	SIZE A3	CAGE CODE 00779
MATERIAL SEE TABLE		FINISH SEE TABLE	DRAWING NO C-1757459	RESTRICTED TO
CUSTOMER DRAWING			SCALE 5:1	SHEET 1 OF 1
			REV A	