

Powered Programming Adapter for Digital Power System Management (PSM) Products

DESCRIPTION

Demonstration circuit 2086A is an accessory board to the DC1613A, DC2026A and DC590B that allows for a higher current 3.4V or 5V output rail and the ability to adapt different input cables to output cables. Extra power is supplied to the downstream device from the DC2086A when it is plugged into an external supply. This can be done via any one of the three input methods: (a) 2.1mm DC input jack, (b) 2-position screw-terminal block, and (c) USB 3.0 Micro-B connector. The DC590B and DC2026A USB dongles both use a 14-pin ribbon cable for power and communication to a connected system board, whereas the DC1613A USB dongle uses a 12-pin ribbon cable for the same purpose. The DC2086A can take either of these 12-pin or 14-pin ribbon cable inputs and adapt to the 12-pin, 14-pin, or newer and smaller 4-pin or 3-pin connectors. This means you are able to use the same USB dongle to power and talk to any of your demo boards even when it does not have the mating connector for the dongle. The DC2086A also allows your PSM devices on your hardware

to be powered via the dongle as well as the ability to keep the "brains" of the PSM device alive independent of the power supply rails on the board, which is extremely useful in any debugging situation.

The 2.1mm DC input jack and 2-position screw-terminal block are in parallel and can accept any DC input between 4.5V and 18V. The USB 3.0 Micro-B connector is backwards-compatible with any USB Micro-B connector, exactly like those found on modern cell phones and consumer electronics. This simplifies cable requirements when you can reach into your bag and pull out one cable that powers all your devices, and plug this board in as if it were your cell phone.

Design files for this circuit board are available at <http://www.linear.com/demo/DC2086A>

LT, LT, LTC, LTM, Linear Technology and the Linear logo are registered trademarks and Hot Swap, Linduino and LTpowerPlay are trademarks of Linear Technology Corporation. All other trademarks are the property of their respective owners. Protected by U.S. Patents, including 7382303 and 7420359.



Figure 1. DC2086A Input and Output Connections

dc2086afb

DEMO MANUAL DC2086A

DC2086A FEATURES

The DC2086A features two input ports supporting both the current recommended 12-pin header used to connect to the DC1613A as well as the legacy 14-pin header used to connect to the DC590B. On the output side, there are the same 12-pin and 14-pin headers in addition to a new smaller footprint 4-pin header. This new header contains ground, I²C Clock (SCL), I²C Data (SDA) and 3.4V power. These four signals allow the minimum for communication with LTpowerPlay™ and external bus controllers (SDA, SCL and GND via 4-pin/3-pin output cable).

- I²C/SMBus Serial Interface
- 2.3A at 3.4V, and 1.3A at 5V Output Power
- 3.4V and 5V Independent Output Power Rails
- Cable Adapter Between 12-Pin and 14-Pin Ribbon Cables to 12-Pin and 14-Pin Ribbon Cables and 3-Pin and 4-Pin Cables

PERFORMANCE SUMMARY $T_A = 25^\circ\text{C}$

PARAMETER	CONDITIONS	MIN	TYP	MAX	UNITS
Supply Input Voltage Range					
J100: 2.1mm Barrel Jack		4.5	12	18	V
J101: Screw Terminals		4.5	12	18	V
J102: USB 3.0 Micro-B		4.5	5	5.5	V
Supply Input Current Range					
J100: 2.1mm Barrel Jack				2.5	A
J101: Screw Terminals				2.5	A
J102: USB 3.0 Micro-B	When Connected Through USB Charging Port			2.1	A
J102: USB 3.0 Micro-B	When Connected Through USB Port With Current Negotiation			0.1	A
J102: USB 3.0 Micro-B	When Connected Through USB Port With Current Limit			0.5	A
J102: USB 3.0 Micro-B	When Connected Through USB Wall Charger			2.5	A
Output Power 3.4V Rail					
Regulation		3	3.4	3.5	V
Current Capability	When Powered from a Capable Input Supply			2.3	A
Output Power 5V Rail					
Regulation		4.75	5	5.1	V
Current Capability	When Powered from a Capable Input Supply			1.3	A

NOTES:

1. Total input current is limited to 2.5A.
2. When drawing current from both the 5V 3.4V rails simultaneously, the total combined output power is limited to 7W.
3. 4.5V is the minimum input voltage, but up to 4.75V input may be required for start-up. After the DC2086A is operational, only then is it possible to regulate down to 4.5V_{IN}.

TYPICAL PERFORMANCE CHARACTERISTICS

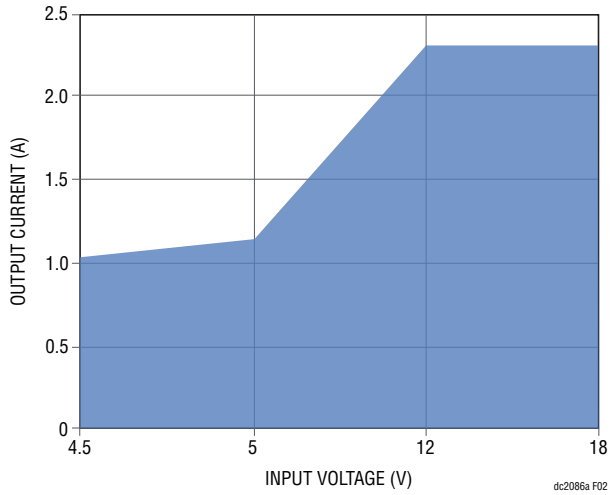

Figure 2. 3.4V I_{OUT} vs V_{IN}

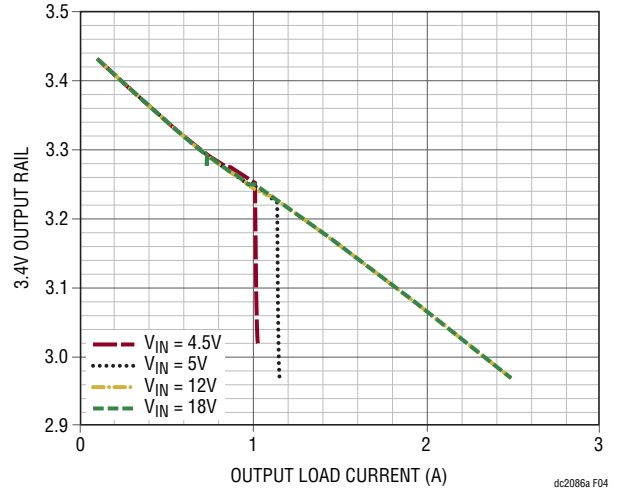

Figure 4. 3.4V V_{OUT} vs I_{OUT}

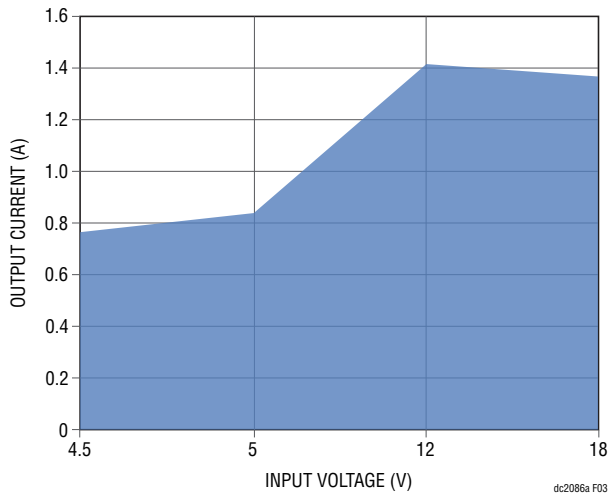

Figure 3. 5V I_{OUT} vs V_{IN}

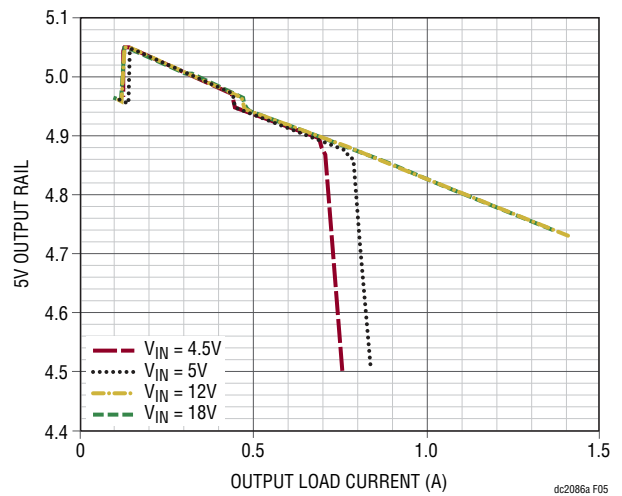

Figure 5. 5V V_{OUT} vs I_{OUT}

SIMPLIFIED BLOCK DIAGRAM

The Simplified Block Diagram shows that the DC2086A can power its output power rail from any combination of three dedicated power input ports (wall power from a 2.1mm barrel jack, turret power from screw terminals, and via a USB connection) or the 5V rail on the upstream 12-pin or 14-pin ribbon cable. Priority for the ideal OR-ing circuits is given to the three dedicated power inputs throughout the chain, making the assumption that if you have it connected to an external power source it is the highest current supply available in the system.

All three dedicated power inputs are fed into the internal DC2086A V_{BUS} . This is a LTC3575 flyback controller providing true magnetic isolation through a Würth 750311675 transformer. This protects your power supplies upstream from anything catastrophic that the boards downstream may experience.

The smaller 4-pin output connector does not have a 5V rail available whereas the 12-pin and 14-pin cables do. Also note that all signal lines are routed straight through from the input connectors to the output connectors.

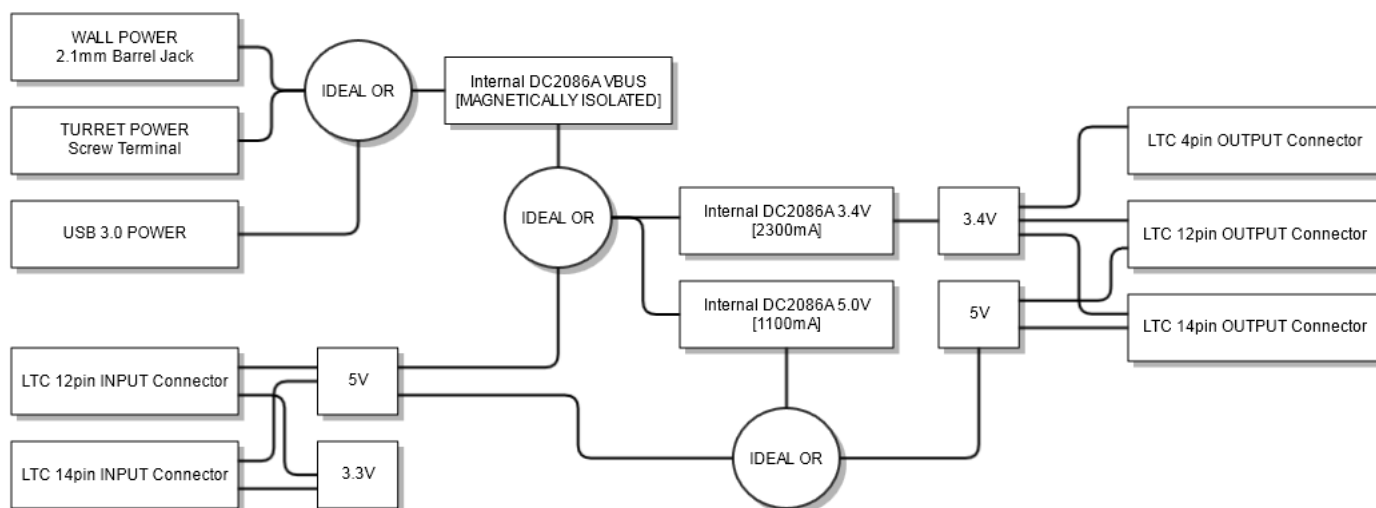

WHEN DO I NEED THIS BOARD?

The DC2086A has many useful features that make it an essential accessory adapter to one of Linear Technology's USB dongles, such as the DC1613A, DC590B, and DC2026A.

The DC590B and DC2026A use a 14-pin ribbon cable for power and communication to a system board, whereas the DC1613A uses a 12-pin ribbon cable. The DC2086A is more versatile and can accept either of these 12-pin or 14-pin ribbon cable inputs and adapt to the 12-pin, 14-pin, or newer and smaller 4-pin or 3-pin connectors.

If designing a board, we highly recommend putting one of these connectors on your board. The reasons are: the ability to program PSM devices onboard, powered via the dongle, and the ability to keep the "brains" of the PSM device alive independent of the power supply rails on the board—which is useful in any debugging situation. When used with LTpowerPlay software, the DC2086A provides a powerful way to debug an entire power system. Failures are

quickly diagnosed using telemetry, fault status registers, and the fault logs. The final system configuration can be quickly developed and stored to the PSM products' respective nonvolatile memories all using this one interface.

In addition to adapting to the various connectors, the DC2086A has two higher current power rails which can provide 3.4V and 5V power to the board. The current USB dongle solutions, such as the DC1613A, can only source around 100mA. This is generally sufficient to power a single device and supporting hardware, and in some cases approximately four LTC products. With the complexity in today's power systems, it is common to have more devices that need power beyond the capability of the USB dongles. In these situations, use the DC2086A to power the board. The DC2086A provides up to 2.3A on the 3.4V rail, which is more than enough to power over a hundred devices on the same power source. Consult the data sheet of the PSM device to verify (this generalization assumes 20mA per PSM device).

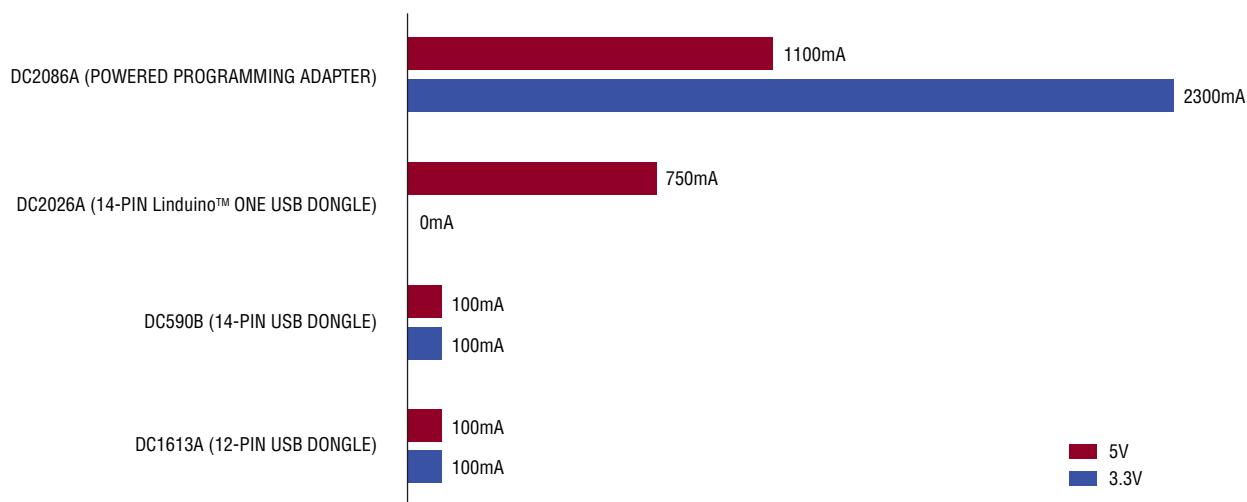

Figure 6. Programming Current Capability Comparison Chart

WHEN DO I NEED THIS BOARD?

Please see Figure 7, Figure 8 and Figure 9 for examples of how to design your board to make full use of these strikingly important features and allow for your PSM products to be powered from the DC2086A.

If you are unsure of which connector to choose to put on your board, you can consult Table 1 through Table 4.

Choosing a connector with power means a minimum of four pins, but it is recommended for all designs. It allows for the most flexibility at all times and enables you to make use of all of the features of the PSM device.

If needed, an adapter to the 4-pin output of DC2086A can be made. Refer to Table 5.

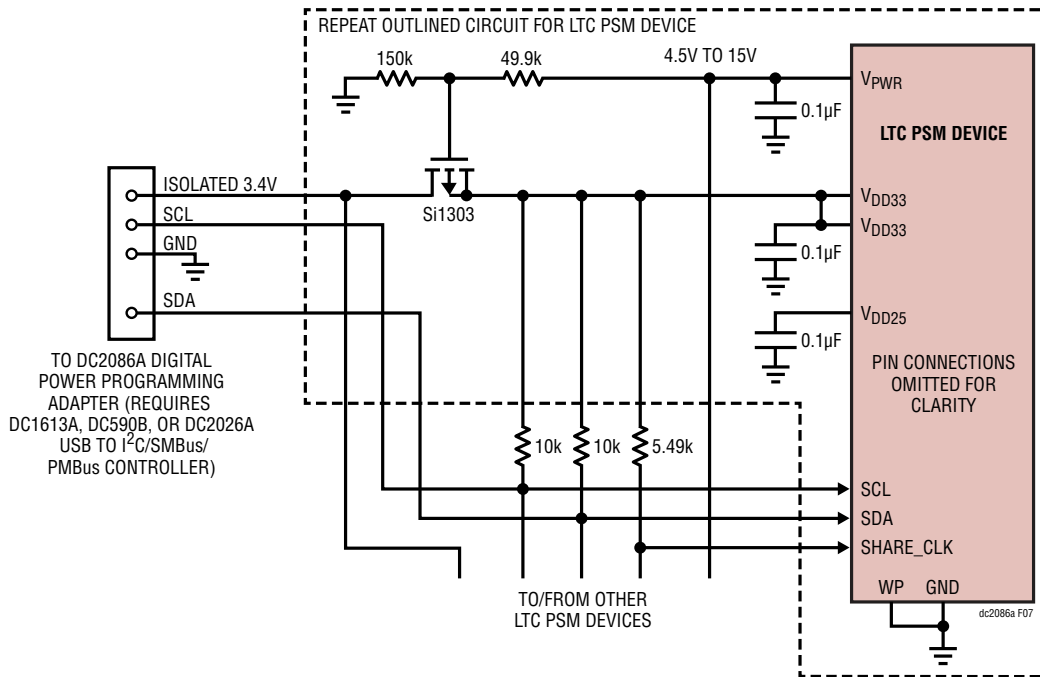

Figure 7. Powering LTC PSM Devices with PFET to V_{PWR}

WHEN DO I NEED THIS BOARD?

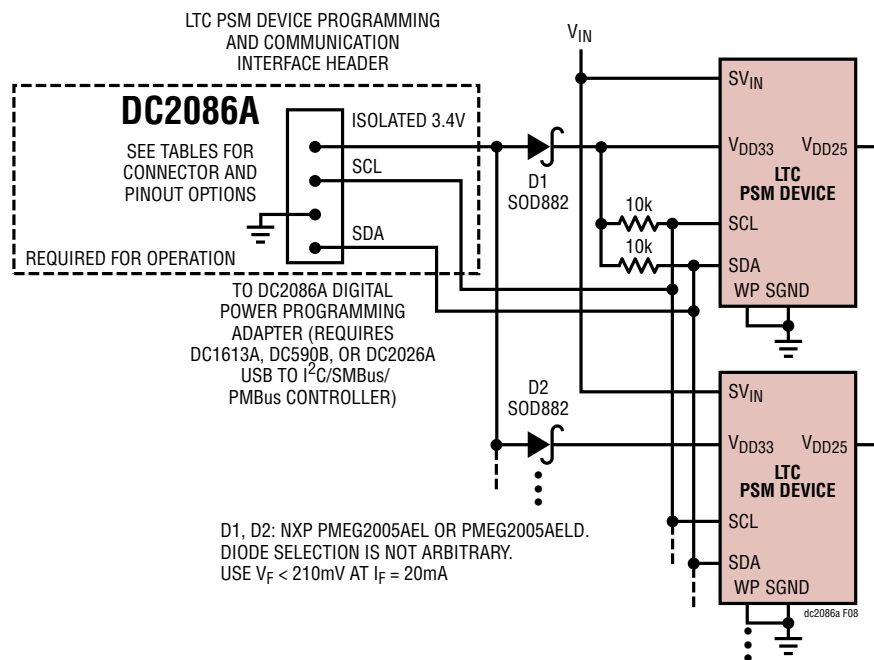

Figure 8. Powering LTC PSM Devices with Individual Device Diode Protection

WHEN DO I NEED THIS BOARD?

Table 1. 4-Pin Headers, 2mm Pin-to-Pin Spacing, Gold Flash or Plating, Compatible with DC2086A Cables

MOUNTING STYLE	INSERTION ANGLE	INTERFACE STYLE	VENDOR	PART NUMBER	PINOUT STYLE (SEE TABLE 3)
Surface Mount	Vertical	Shrouded and Keyed Header	Hirose	DF3DZ-4P-2V(51) DF3Z-4P-2V(50)	Type A
		Non Shrouded, Non-Keyed Header	3M	951104-2530-AR-PR	Type A and B Supported. Reversible/Not Keyed
	Right Angle	Shrouded and Keyed Header	Hirose	DF3DZ-4P-2H(51)	Type A
		Non Shrouded. Cable-to-Header/PCB Mechanics Yield Keying Effect	FCI	10112684-G03-04ULF	Type B. Keying Achieved by PCB Surface
Through-Hole	Vertical	Shrouded and Keyed Header	Hirose	DF3-4P-2DSA(01)	Type A
		Non Shrouded, Non-Keyed Header	Harwin	M22-2010405	Type A and B Supported. Reversible/Not Keyed
			Samtec	TMM-104-01-LS	
	Sullins		NRPNO41PAEN-RC		
	Right Angle	Shrouded and Keyed Header	Hirose	DF3-4P-2DS(01)	Type A
		Non Shrouded. Cable-to-Header/PCB Mechanics Yield Keying Effect	Norcomp	27630402RP2	Type B. Keying Achieved by Intentional PCB Interference
			Harwin	M22-2030405	
			Samtec	TMM-104-01-L-S-RA	

Table 2. 3-Pin Headers, 2mm Pin-to-Pin Spacing, Gold Flash or Plating, Compatible with DC2086A Cables

MOUNTING STYLE	INSERTION ANGLE	INTERFACE STYLE	VENDOR	PART NUMBER	PINOUT STYLE (SEE TABLE 4)
Surface Mount	Vertical	Shrouded and Keyed Header	Hirose	DF3DZ-3P-2V(51) DF3Z-3P-2V(50)	Type A
		Non Shrouded, Non-Keyed Header	3M	951103-2530-AR-PR	Type A and B Supported. Reversible/Not Keyed
	Right Angle	Shrouded and Keyed Header	Hirose	DF3DZ-3P-2H(51)	Type A
		Non Shrouded. Cable-to-Header/PCB Mechanics Yield Keying Effect	FCI	10112684-G03-03LF	Type B. Keying Achieved by PCB Surface
Through-Hole	Vertical	Shrouded and Keyed Header	Hirose	DF3-3P-2DSA(01)	Type A
		Non Shrouded, Non-Keyed Header	Harwin	M22-2010305	Type A and B Supported. Reversible/Not Keyed
			Samtec	TMM-103-01-LS	
	Sullins		NRPNO31PAEN-RC		
	Right Angle	Shrouded and Keyed Header	Hirose	DF3-3P-2DS(01)	Type A
		Non Shrouded. Cable-to-Header/PCB Mechanics Yield Keying Effect	Norcomp	27630302RP2	Type B. Keying Achieved by Intentional PCB Interference
			Harwin	M22-2030305	
			Samtec	TMM-103-01-L-S-RA	

Table 3. Recommended 4-Pin Header Pinout (Pin Numbering Scheme Adheres to Hirose Conventions). Interfaces to DC2086A Cables

PIN NUMBER	PINOUT STYLE "A" (SEE TABLE 9)	PINOUT STYLE "B" (SEE TABLE 9)
1	SDA	3.4V _{OUT}
2	GND	SCL
3	SCL	GND
4	+3.4V	SDA

Table 4. Recommended 4-Pin Header Pinout (Pin Numbering Scheme Adheres to Hirose Conventions). Interfaces to DC2086A Cables

PIN NUMBER	PINOUT STYLE "A" (SEE TABLE 10)	PINOUT STYLE "B" (SEE TABLE 10)
1	SDA	SCL
2	GND	GND
3	SCL	SDA

USB CONNECTORS

Table 5. 4-Pin Male-to-Male Shrouded and Keyed Adapter (Optional. Eases Creation of Adapter Cables, if Deviating from Recommended Connectors/Connector Pinouts). Interfaces to DC2086 Cables

Vendor	Part Number	Website
Hirose	DF3-4EP-2A	www.hirose.com, www.hirose.co.jp

The DC2086A uses a USB 3.0 SuperSpeed Micro-B male connector as a possible input power source. This connector is 100% backwards-compatible with the now ubiquitous USB 2.0 Micro-B male connector that is found on the end of countless device chargers and is officially the global standard for charging with the title of Universal Charging Solution.

If a legacy USB 2.0 Micro-B male connector is used with the DC2086A, it will fit into the portion of the USB 3.0 Micro-B socket on the left of the device, as shown in Figure 10.

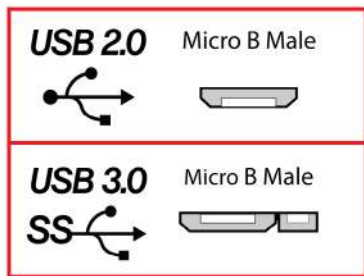

Figure 10. Difference Between USB 2.0 and 3.0 Micro B Male Connectors



Figure 11. DC2086A USB Input Connector

To get the most output power from your DC2086A whilst being supplied by the USB port, connect it to an external wall charger with at least a 2A output rating. Newer smart-phone and tablet chargers generally meet this specification, as shown in Figure 12. The use of a lower output capacity charger will only limit the total output power available from the DC2086A.

If the DC2086A is powered from a computer port that does not accept the charging port protocol, but does strictly enforce downstream port power management, the total input current will be limited to 100mA.

If the DC2086A is powered from a computer port that does recognize the charging port protocol, the total input current will be limited to 2.3A.

If the DC2086A is powered from a computer port with no management, or a wall adapter with no management, it will happily draw up to 2.5A through the USB connector. If unsure whether the computer or wall adapter is managed, do not use that port to power the DC2086A.



Figure 12. For More Power Delivered by USB Port Use a Wall Charger

PINOUT INFORMATION

Tables 6-8 list the pinouts of the three different output connectors found on the DC2086A along with their manufacturer and manufacturer part number. The 12-pin ribbon cable connector described in Table 6 is the recommended connector if you can afford the physical size.

Table 6. 12-Pin Ribbon Cable Connector [FCI 98414-F06-12ULF]

PIN	DESCRIPTION
1	+5V DC2086A Output
2	SDA
3	GND
4	SCL
5	+3.4V DC2086A Output
6	ALERT
7	GPO #1
8	OUTPUT ENABLE
9	GPO #2
10	GND
11	EEPROM SCL
12	EEPROM SDA

Table 7. 4-Pin Ribbon Cable Connector [Hirose DF3-4P-2DS(01)]

PIN	DESCRIPTION
1	SDA
2	GND
3	SCL
4	+3.4V DC2086A Output

Table 8. 14-Pin Ribbon Cable Connector [FCI 98414-F06-14ULF]

PIN	DESCRIPTION
1	+5V DC2086A Output
2	+3.4V DC2086A Output
3	GND
4	SCK/SCL
5	MISO
6	CS
7	MOSI/SDA
8	GND
9	EEPROM SDA
10	+5V DC2086A Output
11	EEPROM SCL
12	GND
13	GND
14	GPIO #1

DEMO MANUAL DC2086A

DETAILS: TOP

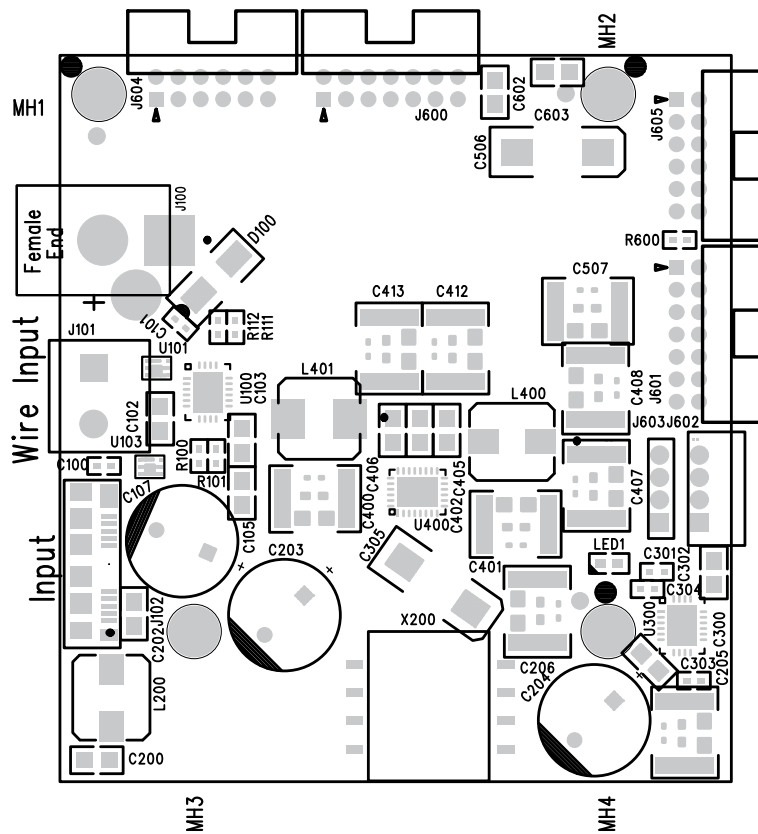
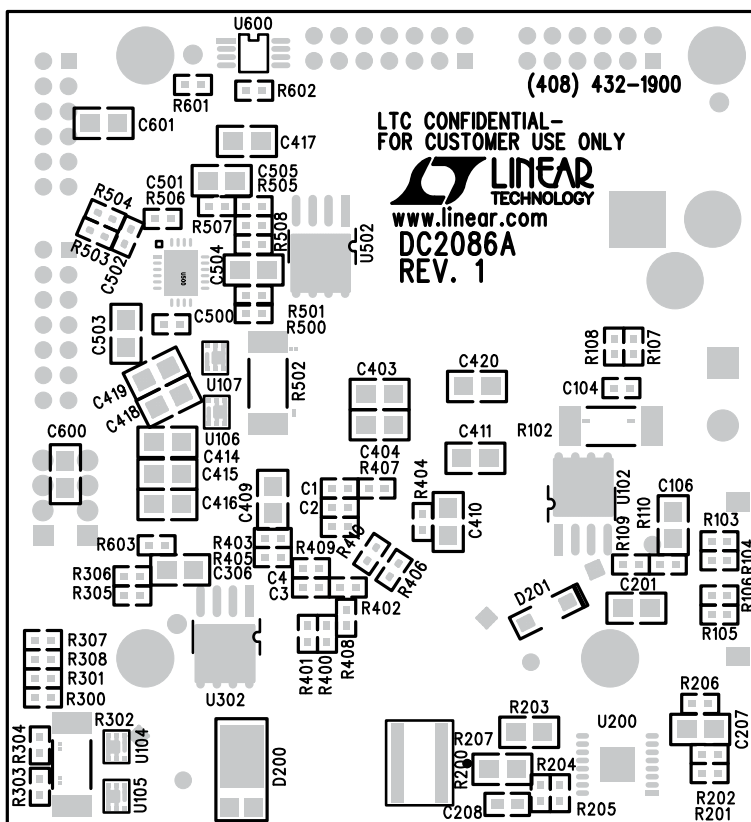

Table 9. DC2086A Connector Details

REFERENCE DESIGNATOR	CONNECTOR DETAILS	USAGE SPECIFICATIONS
J100	2.1mm DC Jack	Any DC-voltage wall wart or power supply with sufficient output power capabilities to drive the target load with an output voltage between 4.5V and 18V. Recommended: 12V wall wart for full output current capabilities.
J101	2-Position Screw Terminal	In parallel with J100. Same specifications as J100.
J102	USB 3.0 Micro-B	Any USB port or wall charger can be used. Follows USB Charging Specification to safely draw up to 2.1A from supporting chargers (yellow-colored ports). Can also be used with any standard computer port, but current will be limited by USB specification to between 100mA and 500mA depending on USB system controller design. In addition, can be used with USB wall chargers.
J503	12-Pin DC1613A Input	Connect to a 12-pin DC1613A. Only one input port should be used at one time.
J505	14-Pin DC590B/DC2026A Input	Connect to a 14-pin DC590B/DC2026A. Only one input port should be used at one time.
J502	12-Pin DC1613A Output	Connect to target board with 12-pin female/female DC1613A cable.
J504	14-Pin DC590B/DC2026A Output	Connect to target board with 14-pin female/female DC590B/DC2026A cable.
J500/J501	4-Pin Minimum Output	Connect to target board via 4-pin female/female cable via J500 or solder custom leads to J501.

DETAILS: BOTTOM



DEMO MANUAL DC2086A

PARTS LIST

ITEM	QTY	REFERENCE	PART DESCRIPTION	MANUFACTURER/PART NUMBER
1	2	C1, C3	Multilayer Ceramic Capacitors MLCC: SMD/SMT, CAP, MLCC, 0402, 50V, X7R, 2200pF, 10%	C0402C222K5RACTU
2	2	C100, C101	Multilayer Ceramic Capacitors MLCC: SMD/SMT, CAP, MLCC, 0402, 50V, X7R, 22000pF, 10%	C0402C223K5RACTU
3	20	C102, C103, C106, C303, C304, C306, C403, C404, C405, C406, C417, C418, C419, C420, C503, C504, C600, C601, C602, C603	Multilayer Ceramic Capacitors MLCC: SMD/SMT, CAP, MLCC, 0805, 50V, X7R, 100nF, 10%	CC0805KRX7R9BB104
4	3	C104, C302, C502	Multilayer Ceramic Capacitors MLCC: SMD/SMT, CAP, MLCC, 0402, 25V, X5R, 0.1µF, 10%	TMK105BJ104KV-F
5	3	C105, C200, C202	Multilayer Ceramic Capacitors MLCC: SMD/SMT, CAP, MLCC, 0805, 25V, X5R, 4.7µF, 10%	TMK212BJ475KG-T
6	3	C107, C203, C204	Aluminum Organic Polymer Capacitors 20V, 680µF, 20%, ESR = 20µΩ	APSG200ELL681MJB5S
7	1	C201	Multilayer Ceramic Capacitors MLCC: SMD/SMT, CAP, MLCC, 0805, 50V, X7R, 0.22µF, 10%	08055C224KAT4A
8	9	C205, C206, C400, C401, C407, C408, C412, C413, C507	Multilayer Ceramic Capacitors MLCC: SMD/SMT, DOUBLE STACKED CAP, MLCC, 2220, 25V, X7R, 47µF, 20%	C2220C476M3R2CAUTO
9	1	C207	Multilayer Ceramic Capacitors MLCC: SMD/SMT, CAP, MLCC, 0805, 50V, C0G 0.01µF, 5%	CGA4C2C0G1H103J060AA
10	1	C208	Multilayer Ceramic Capacitors MLCC: SMD/SMT, CAP, MLCC, 0603 25V, X7R, 33000pF, 5%	C0603C333J3RACTU
11	4	C300, C301, C500, C501	Multilayer Ceramic Capacitors MLCC: SMD/SMT, CAP, MLCC, 0805, 25V, X7R, 22000pF, 10%	C0402C223K3RACTU
12	2	C305, C506	Aluminum Organic Polymer Capacitors 12.5V, 100µF, 20%, ESR = 15mΩ	A700X107M12RATE015
13	2	C402, C411	Multilayer Ceramic Capacitors MLCC: SMD/SMT, CAP, MLCC, 0805, 16V, X7R, 2.2µF, 10%	GRM21BR71C225KA12L
14	2	C409, C410	Multilayer Ceramic Capacitors MLCC: SMD/SMT, CAP, MLCC, 0805, 50V, NPO, 22pF, 5%	CC0805JRNPO9BN220
15	3	C414, C415, C416	Multilayer Ceramic Capacitors MLCC: SMD/SMT, CAP, MLCC, 0805, 25V, X7R, 1µF, 10%	TMK212B7105KG-T
16	1	C505	Multilayer Ceramic Capacitors MLCC: SMD/SMT, CAP, MLCC, 0805, 50V, X7R, 0.1µF, 5%	C0805C104J5RACTU
17	1	D100	TVS Diodes: Transient Voltage Suppressors, 400W, 18V	SMAJ18A-13-F
18	1	D200	Schottky Diodes	PDS835L-13
19	1	D201	Schottky Diodes	PMEG6010ER,115
20	1	J100	DC Power Connectors PCB 2.1mm	163-179PH-EX

dc2086afb

PARTS LIST

ITEM	QTY	REFERENCE	PART DESCRIPTION	MANUFACTURER/PART NUMBER
21	1	J101	Terminal Block, 5mm HORZ ENTRY MOD 2POS	Würth Elektronik, 691102710002
22	1	J102	USB Connectors WR-COM Micro USB 3.0 Horizontal B	Würth Elektronik, 692622030100
23	2	J600, J601	Headers: 14-Pin, 2mm, Shrouded and Keyed	98464-G61-14ULF
24	1	J602	Headers: 4-Pin, 2mm, Shrouded and Keyed	DF3-4P-2DS(01)
25	2	J604, J605	Headers: 12-Pin, 2mm, Shrouded and Keyed	98464-G61-12LF
26	1	L200	Fixed Inductors, WE-HCI Inductor, 4.9µH, 100kHz, 6.5A	Würth Elektronik, 744314490
27	1	L400	Fixed Inductors, WE-HCI Inductor, 1.5µH, 100kHz, 13A	Würth Elektronik, 744314150
28	1	L401	Fixed Inductors, SMD Inductor, WE-LHMI 7050, 1.0µH, 10A	Würth Elektronik, 74437349010
29	1	Light Pipe	LED Light Pipes: 5mm Round Lens	PLP5-2-625
30	1	LED101	WL-SMCW SMD, CHIP, LED, Waterclear Blue	Würth Elektronik, 150060BS75000
31	1	R101	Thick Film Resistors: SMD, 0402, 0Ω, 5%	ERJ-2GE0R00X
32	3	R102, R302, R502	Current Sense Resistors: SMD, 2512, 1W, 0.024Ω, 1%,	WSL2512R0240FEK
33	1	R103	Thick Film Resistors: SMD, 0402, 78.7kΩ, 1%	ERJ-2RKF7872X
34	7	R104, R106, R112, R301, R308, R501, R508	Thick Film Resistors: SMD, 0402, 100kΩ, 1%	ERJ-2RKF1003X
35	2	R105, R111	Thick Film Resistors: SMD, 0402, 150kΩ, 1%	ERJ-2RKF1503X
36	6	R107, R108, R303, R304, R503, R504	Thick Film Resistors: SMD, 0402, 0.5Ω, 1%	RL0402FR-070R5L
37	6	R109, R110, R305, R306, R505, R506	Thin Film Resistors: SMD, 0805, 3.16kΩ, 0.1%	RT0805BRD073K16L
38	1	R200	Thick Film Resistors: SMD, 1225, 1kΩ, 1%, 100ppm, 2W	RCL12251K00FKEG
39	1	R201	Thick Film Resistors: SMD, 0402, 187kΩ, 1%	ERJ-2RKF1873X
40	1	R202	Thick Film Resistors: SMD, 0402, 90.9kΩ, 1%	ERJ-2RKF9092X
41	1	R203	Thick Film Resistors: SMD, 0805, 102kΩ, 1%	ERJ-6ENF1023V
42	1	R204	Thick Film Resistors: SMD, 0402, 6.04kΩ, 1%	ERJ-2RKF6041X
43	1	R205	Thick Film Resistors: SMD, 0402, 30kΩ, 1%	ERJ-2RKF3002X
44	2	R206, R405	Thick Film Resistors: SMD, 0402, 10kΩ, 1%	ERJ-2RKF1002X
45	1	R207	Thick Film Resistors: SMD, 0805, 1kΩ, 1%	ERJ-6ENF1001V
46	1	R300	Thick Film Resistors: SMD, 0402, 191kΩ, 1%	ERJ-2RKF1913X
47	2	R307, R507	Thick Film Resistors: SMD, 0402, 169kΩ, 1%	ERJ-2RKF1693X
48	1	R401	Thick Film Resistors: SMD, 0402, 200kΩ, 1%	ERJ-2RKF2003X
49	1	R403	Thick Film Resistors: SMD, 0402, 73.2kΩ, 1%	ERJ-2RKF7322X
50	1	R404	Thin Film Resistors: SMD, 0402, 4.64kΩ, 0.1%, 25ppm	CPF0402B4K64E1
51	1	R406	Thin Film Resistors: SMD, 0402, 1kΩ, 1%	ERA-2AEB102X
52	1	R407	Thick Film Resistors: SMD, 0402, 4.99kΩ, 1%	ERJ-2RKF4991X
53	1	R408	Thick Film Resistors: SMD, 0402, 8.66kΩ, 1%	ERJ-2RKF8661X
54	2	R601, R602	Thick Film Resistors: SMD, 0402, 20kΩ, 1%	ERJ-2RKF2002X
55	1	R603	Thick Film Resistors: SMD, 0402, 249Ω, 1%	ERJ-2RKF2490X
56	3	U100, U300, U500	LTC4227: Dual Ideal Diode and Single Hot Swap Controller	Linear Technology, LTC4227CUFD-2

DEMO MANUAL DC2086A

PARTS LIST

ITEM	QTY	REFERENCE	PART DESCRIPTION	MANUFACTURER/PART NUMBER
57	1	U200	LT3575: Isolated Flyback Converter without an Opto-Coupler	Linear Technology, LT3575EFE
58	1	U400	LTC3633A/LTC3633A-1: Dual Channel 3A, 20V, Monolithic Synchronous Step-Down Regulator	Linear Technology, LTC3633A
59	1	U600	LTC4313: 2-Wire Bus Buffers with High Noise Margin	Linear Technology, LTC4313CMS8-2
60	6	U101, U103, U104, U105, U106, U107	MOSFET N-Ch, 30V, 0.021 Ω , 6A, STripFET VI DG	STL6N3LLH6
61	3	U102, U302, U502	MOSFET 30V, 30A, 5.4W, 3.0 $\mu\Omega$ at 10V	SI7336ADP-T1-E3
62	1	X200	WE-FB Flyback Transformer Suitable, or LT3573/LT3574/LT3575/LT3748	Würth Elektronik, 750311675
63	9	C2, C4, J603, R100, R400, R402, R409, R410, R500, R600	Do Not Populate These Parts on the Board for Standard Operation.	DNP: Do Not Install!

SCHEMATIC DIAGRAMS

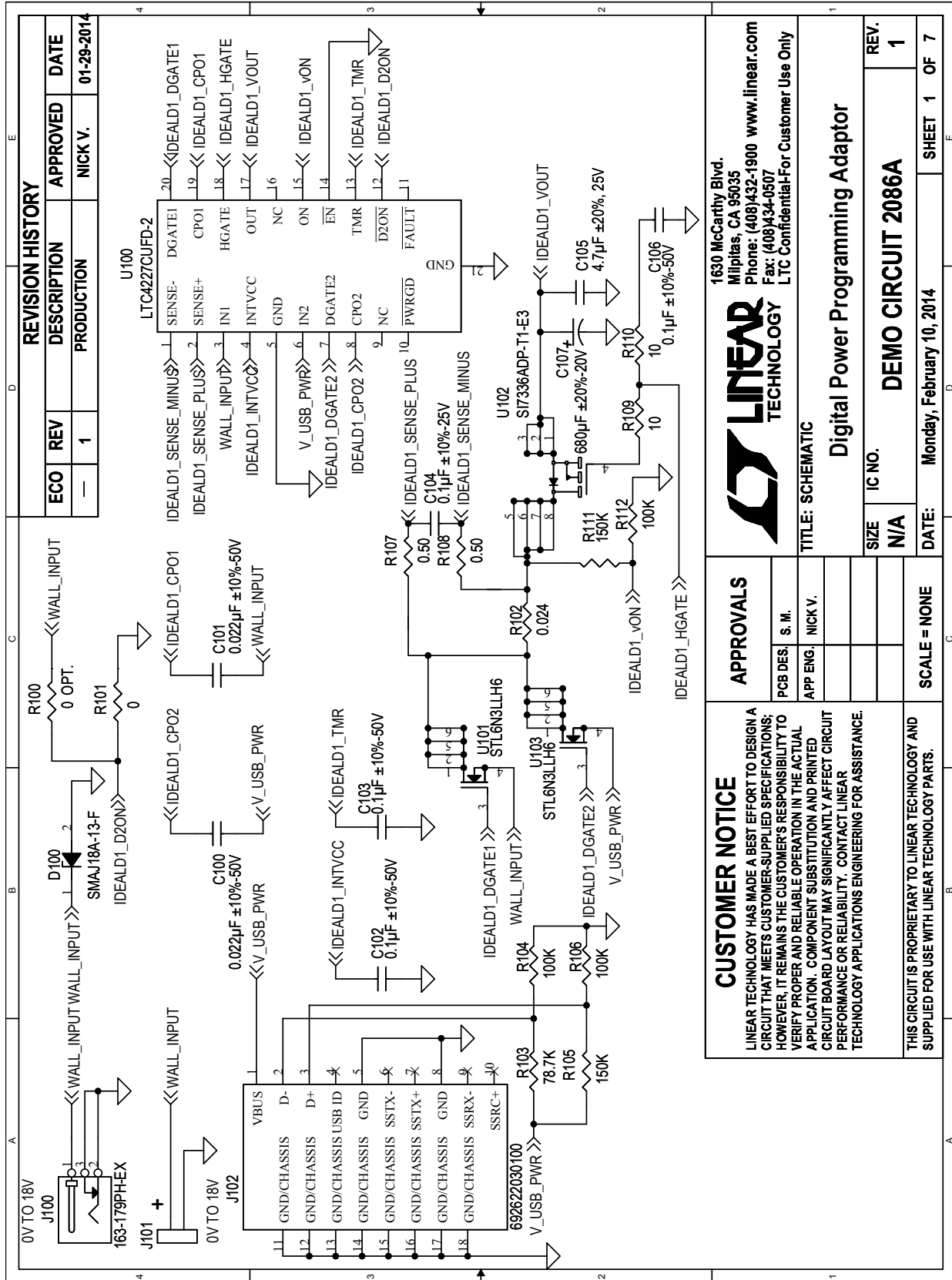

1630 McCarthy Blvd.
Milpitas, CA 95035
Phone: (408)432-1900 www.linear.com
Fax: (408)434-0507
LTC Confidential-For Customer Use Only

TITLE: SCHEMATIC
Digital Power Programming Adaptor

SIZE	IC NO.	REV.
N/A	DEMO CIRCUIT 2086A	1

DATE: Monday, February 10, 2014 SHEET 1 OF 7

CUSTOMER NOTICE
LINEAR TECHNOLOGY HAS MADE A BEST EFFORT TO DESIGN A CIRCUIT THAT MEETS CUSTOMER-SUPPLIED SPECIFICATIONS; HOWEVER, IT REMAINS THE CUSTOMER'S RESPONSIBILITY TO VERIFY PROPER AND RELIABLE OPERATION IN THE ACTUAL APPLICATION. COMPONENT SUBSTITUTION AND PRINTED CIRCUIT BOARD LAYOUT MAY SIGNIFICANTLY AFFECT CIRCUIT PERFORMANCE OR RELIABILITY. CONTACT LINEAR TECHNOLOGY APPLICATIONS ENGINEERING FOR ASSISTANCE.

APPROVALS

PCB DES. S. M.	
APP ENG. NICK V.	

SCALE = NONE

THIS CIRCUIT IS PROPRIETARY TO LINEAR TECHNOLOGY AND SUPPLIED FOR USE WITH LINEAR TECHNOLOGY PARTS.

SCHEMATIC DIAGRAMS

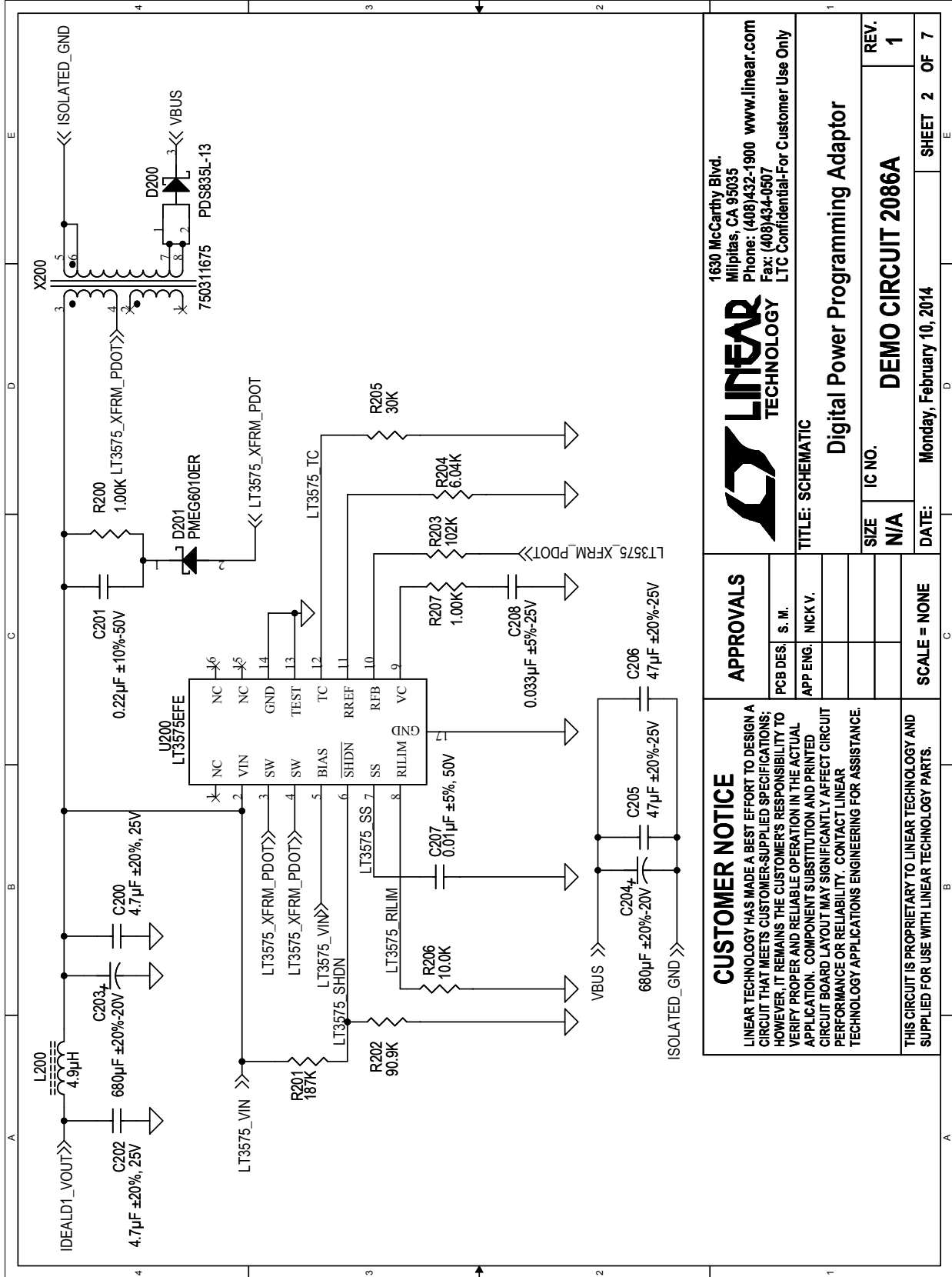

<p>CUSTOMER NOTICE</p> <p>LINEAR TECHNOLOGY HAS MADE A BEST EFFORT TO DESIGN A CIRCUIT THAT MEETS CUSTOMER-SUPPLIED SPECIFICATIONS; HOWEVER, IT REMAINS THE CUSTOMER'S RESPONSIBILITY TO VERIFY PROPER AND RELIABLE OPERATION IN THE ACTUAL APPLICATION. COMPONENT SUBSTITUTION AND PRINTED CIRCUIT BOARD LAYOUT MAY SIGNIFICANTLY AFFECT CIRCUIT PERFORMANCE OR RELIABILITY. CONTACT LINEAR TECHNOLOGY APPLICATIONS ENGINEERING FOR ASSISTANCE.</p>		<p>APPROVALS</p>		
		<p>PCB DES. s. m.</p>	<p>APP ENG. NICK V.</p>	<p>SCALE = NONE</p>
<p>CUSTOMER NOTICE</p> <p>THIS CIRCUIT IS PROPRIETARY TO LINEAR TECHNOLOGY AND SUPPLIED FOR USE WITH LINEAR TECHNOLOGY PARTS.</p>		<p>SIZE N/A</p>	<p>IC NO. DEMO CIRCUIT 2086A</p>	<p>REV. 1</p>
<p>1630 McCarthy Blvd. Milpitas, CA 95035 Phone: (408)432-1900 www.linear.com Fax: (408)434-0507 LTC Confidential-For Customer Use Only</p>		<p>LINEAR TECHNOLOGY</p>		<p>SHEET 2 OF 7</p>
<p>Digital Power Programming Adaptor</p>		<p>TITLE: SCHEMATIC</p>		<p>DATE: Monday, February 10, 2014</p>

SCHEMATIC DIAGRAMS

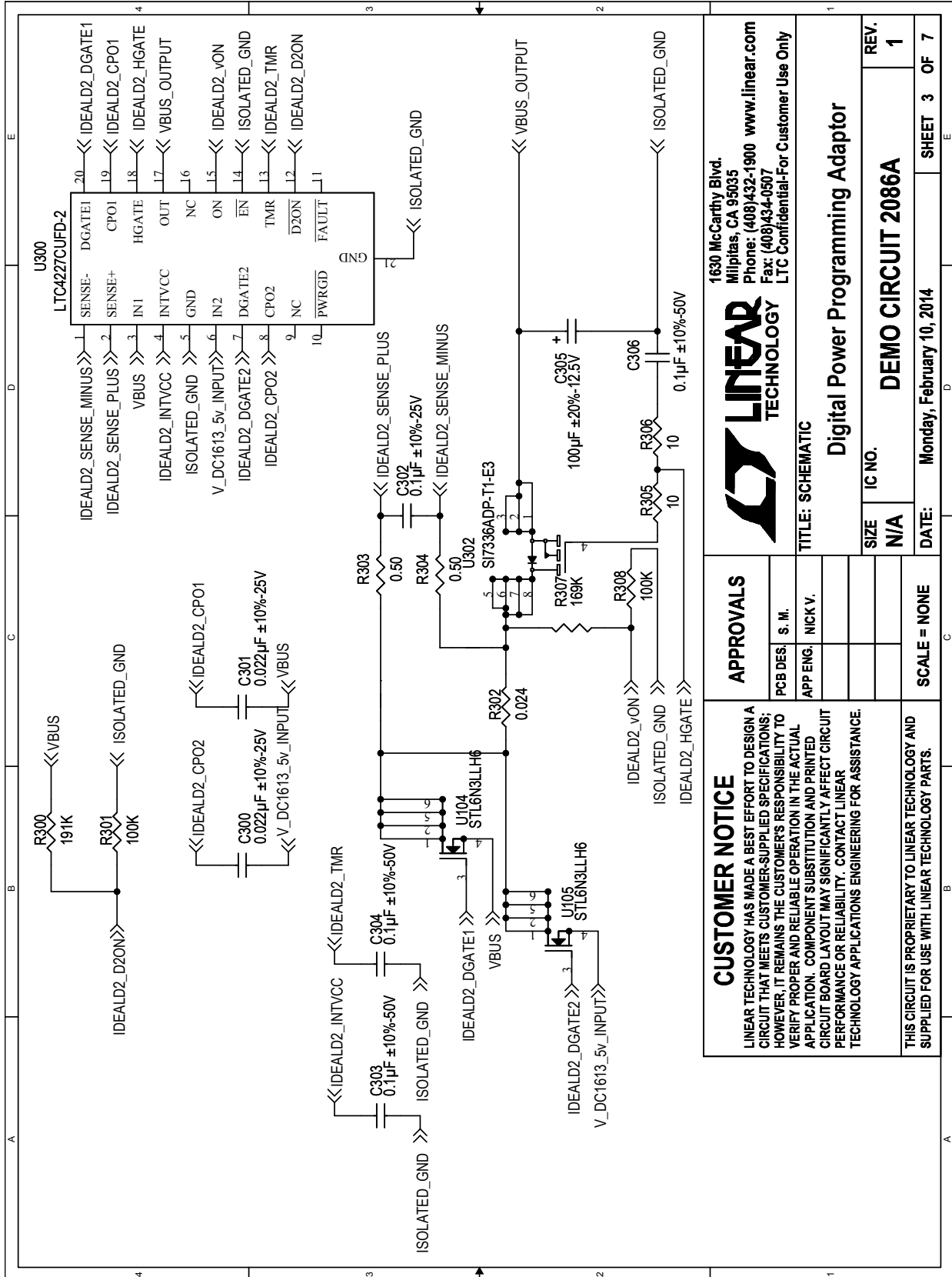

dc2086afb

SCHEMATIC DIAGRAMS

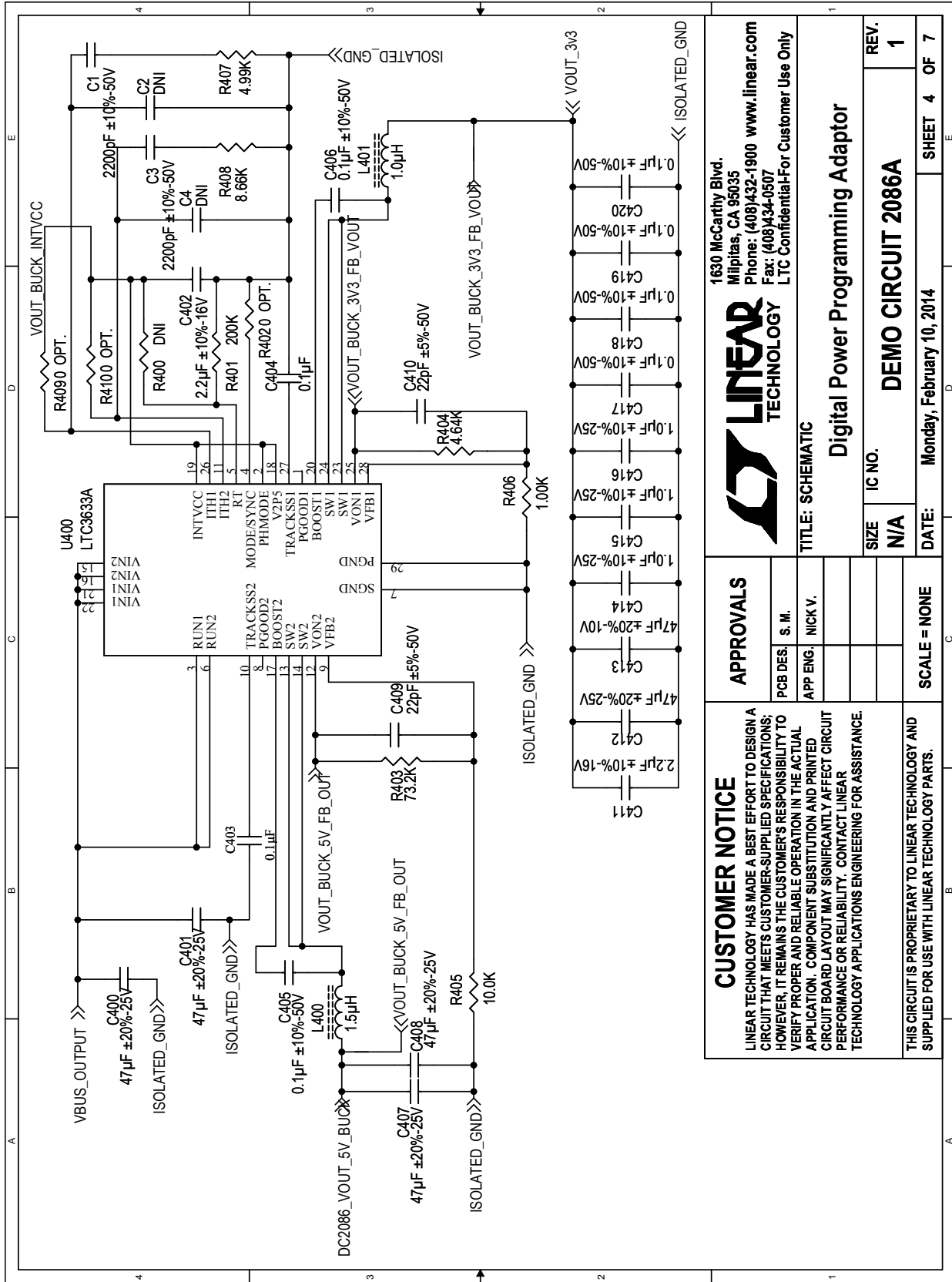

dc2086afb

SCHEMATIC DIAGRAMS

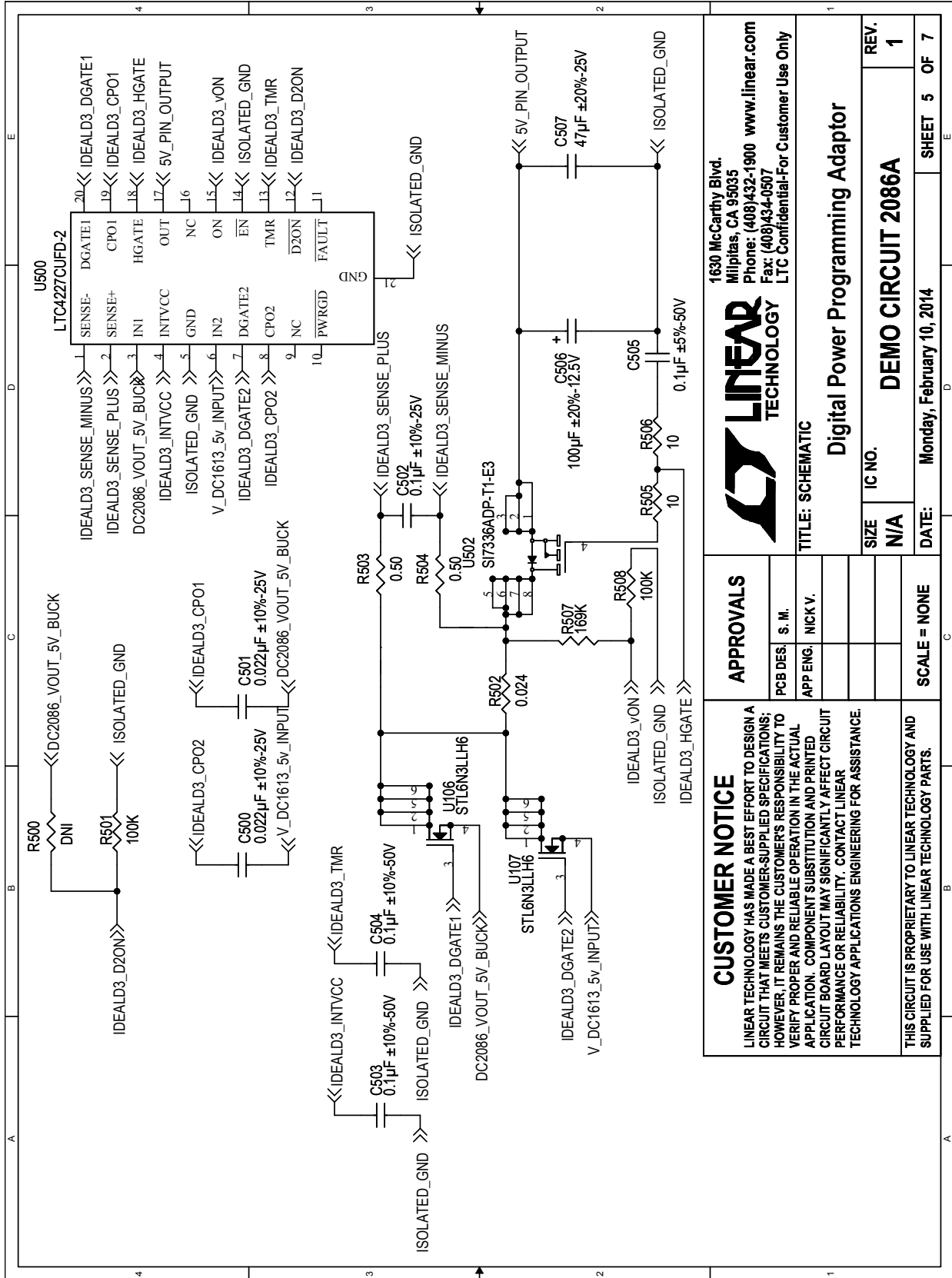

APPROVALS		<p>CUSTOMER NOTICE</p> <p>LINEAR TECHNOLOGY HAS MADE A BEST EFFORT TO DESIGN A CIRCUIT THAT MEETS CUSTOMER-SUPPLIED SPECIFICATIONS; HOWEVER, IT REMAINS THE CUSTOMER'S RESPONSIBILITY TO VERIFY PROPER AND RELIABLE OPERATION IN THE ACTUAL APPLICATION. COMPONENT SUBSTITUTION AND PRINTED CIRCUIT BOARD LAYOUT MAY SIGNIFICANTLY AFFECT CIRCUIT PERFORMANCE OR RELIABILITY. CONTACT LINEAR TECHNOLOGY APPLICATIONS ENGINEERING FOR ASSISTANCE.</p>
PCB DES.	S. M.	
APP ENG.	NICK V.	
SCALE = NONE		<p>THIS CIRCUIT IS PROPRIETARY TO LINEAR TECHNOLOGY AND SUPPLIED FOR USE WITH LINEAR TECHNOLOGY PARTS.</p>
SCALE = NONE		
LINEAR TECHNOLOGY		<p>Digital Power Programming Adaptor</p>
<p>1630 McCarthy Blvd. Milpitas, CA 95035 Phone: (408)432-1900 www.linear.com Fax: (408)434-0507 LTC Confidential-For Customer Use Only</p>		
SIZE	IC NO.	REV.
N/A	DEMO CIRCUIT 2086A	1
DATE:	Monday, February 10, 2014	SHEET 5 OF 7

dc2086afb

DEMO MANUAL DC2086A

SCHEMATIC DIAGRAMS

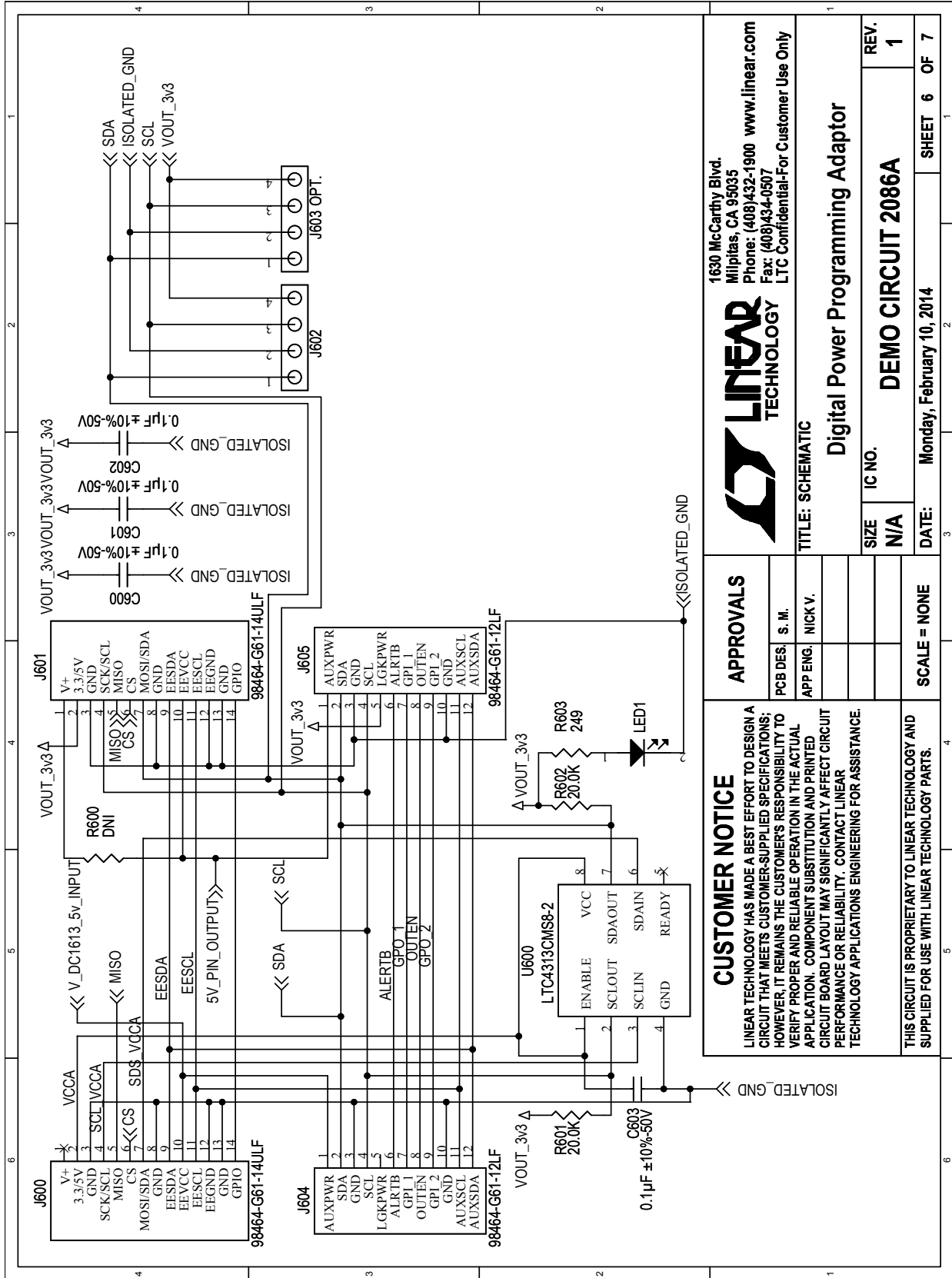

1630 McCarthy Blvd.
Milpitas, CA 95035
Phone: (408)432-1900 www.linear.com
Fax: (408)434-0907
LTC Confidential-For Customer Use Only



TITLE: SCHEMATIC

Digital Power Programming Adaptor

SIZE N/A

IC NO. DEMO CIRCUIT 2086A

REV. 1

DATE: Monday, February 10, 2014

SHEET 6 OF 7

APPROVALS

PCB DES. S. M.

APP ENG. NICK V.

SCALE = NONE

CUSTOMER NOTICE

LINEAR TECHNOLOGY HAS MADE A BEST EFFORT TO DESIGN A CIRCUIT THAT MEETS CUSTOMER-SUPPLIED SPECIFICATIONS; HOWEVER, IT REMAINS THE CUSTOMER'S RESPONSIBILITY TO VERIFY PROPER AND RELIABLE OPERATION IN THE ACTUAL APPLICATION. COMPONENT SUBSTITUTION AND PRINTED CIRCUIT BOARD LAYOUT MAY SIGNIFICANTLY AFFECT CIRCUIT PERFORMANCE OR RELIABILITY. CONTACT LINEAR TECHNOLOGY APPLICATIONS ENGINEERING FOR ASSISTANCE.

THIS CIRCUIT IS PROPRIETARY TO LINEAR TECHNOLOGY AND SUPPLIED FOR USE WITH LINEAR TECHNOLOGY PARTS.

SCHEMATIC DIAGRAMS

<div style="border: 1px solid black; padding: 20px; width: 80%; margin: auto;"> <p style="font-size: 24px; margin: 0;">BOARD STANDOFF HARDWARE</p> </div>	<p style="font-size: 10px; margin: 0;">APPROVALS</p> <table border="1" style="width: 100%; border-collapse: collapse;"> <tr> <td style="width: 30%; font-size: 8px;">PCB DES.</td> <td style="width: 30%; font-size: 8px;">S. M.</td> <td style="width: 40%;"></td> </tr> <tr> <td style="font-size: 8px;">APP ENG.</td> <td style="font-size: 8px;">NICK V.</td> <td></td> </tr> <tr> <td style="font-size: 8px;"> </td> <td style="font-size: 8px;"> </td> <td></td> </tr> <tr> <td style="font-size: 8px;"> </td> <td style="font-size: 8px;"> </td> <td></td> </tr> <tr> <td colspan="3" style="font-size: 8px;">SCALE = NONE</td> </tr> </table>	PCB DES.	S. M.		APP ENG.	NICK V.								SCALE = NONE			<p style="font-size: 10px; margin: 0;">CUSTOMER NOTICE</p> <p style="font-size: 8px; margin: 0;">LINEAR TECHNOLOGY HAS MADE A BEST EFFORT TO DESIGN A CIRCUIT THAT MEETS CUSTOMER-SUPPLIED SPECIFICATIONS; HOWEVER, IT REMAINS THE CUSTOMER'S RESPONSIBILITY TO VERIFY PROPER AND RELIABLE OPERATION IN THE ACTUAL APPLICATION. COMPONENT SUBSTITUTION AND PRINTED CIRCUIT BOARD LAYOUT MAY SIGNIFICANTLY AFFECT CIRCUIT PERFORMANCE OR RELIABILITY. CONTACT LINEAR TECHNOLOGY APPLICATIONS ENGINEERING FOR ASSISTANCE.</p> <p style="font-size: 8px; margin: 0;">THIS CIRCUIT IS PROPRIETARY TO LINEAR TECHNOLOGY AND SUPPLIED FOR USE WITH LINEAR TECHNOLOGY PARTS.</p>
PCB DES.	S. M.																
APP ENG.	NICK V.																
SCALE = NONE																	
<p style="font-size: 10px; margin: 0;">LINEAR TECHNOLOGY</p> <p style="font-size: 8px; margin: 0;">1630 McCarthy Blvd. Milpitas, CA 95035 Phone: (408)432-1900 www.linear.com Fax: (408)434-0507 LTC Confidential-For Customer Use Only</p>																	
<p style="font-size: 10px; margin: 0;">Digital Power Programming Adaptor</p> <table border="1" style="width: 100%; border-collapse: collapse;"> <tr> <td style="width: 30%; font-size: 8px;">TITLE: SCHEMATIC</td> <td style="width: 30%;"></td> <td style="width: 40%;"></td> </tr> <tr> <td style="font-size: 8px;">SIZE</td> <td style="font-size: 8px;">IC NO.</td> <td style="font-size: 8px;">REV.</td> </tr> <tr> <td style="font-size: 8px;">N/A</td> <td style="font-size: 8px;">DEMO CIRCUIT 2086A</td> <td style="font-size: 8px;">1</td> </tr> <tr> <td style="font-size: 8px;">DATE:</td> <td colspan="2" style="font-size: 8px;">Monday, February 10, 2014</td> </tr> <tr> <td colspan="2"></td> <td style="font-size: 8px;">SHEET 7 OF 7</td> </tr> </table>			TITLE: SCHEMATIC			SIZE	IC NO.	REV.	N/A	DEMO CIRCUIT 2086A	1	DATE:	Monday, February 10, 2014				SHEET 7 OF 7
TITLE: SCHEMATIC																	
SIZE	IC NO.	REV.															
N/A	DEMO CIRCUIT 2086A	1															
DATE:	Monday, February 10, 2014																
		SHEET 7 OF 7															

DEMO MANUAL DC2086A

DEMONSTRATION BOARD IMPORTANT NOTICE

Linear Technology Corporation (LTC) provides the enclosed product(s) under the following **AS IS** conditions:

This demonstration board (DEMO BOARD) kit being sold or provided by Linear Technology is intended for use for **ENGINEERING DEVELOPMENT OR EVALUATION PURPOSES ONLY** and is not provided by LTC for commercial use. As such, the DEMO BOARD herein may not be complete in terms of required design-, marketing-, and/or manufacturing-related protective considerations, including but not limited to product safety measures typically found in finished commercial goods. As a prototype, this product does not fall within the scope of the European Union directive on electromagnetic compatibility and therefore may or may not meet the technical requirements of the directive, or other regulations.

If this evaluation kit does not meet the specifications recited in the DEMO BOARD manual the kit may be returned within 30 days from the date of delivery for a full refund. **THE FOREGOING WARRANTY IS THE EXCLUSIVE WARRANTY MADE BY THE SELLER TO BUYER AND IS IN LIEU OF ALL OTHER WARRANTIES, EXPRESSED, IMPLIED, OR STATUTORY, INCLUDING ANY WARRANTY OF MERCHANTABILITY OR FITNESS FOR ANY PARTICULAR PURPOSE. EXCEPT TO THE EXTENT OF THIS INDEMNITY, NEITHER PARTY SHALL BE LIABLE TO THE OTHER FOR ANY INDIRECT, SPECIAL, INCIDENTAL, OR CONSEQUENTIAL DAMAGES.**

The user assumes all responsibility and liability for proper and safe handling of the goods. Further, the user releases LTC from all claims arising from the handling or use of the goods. Due to the open construction of the product, it is the user's responsibility to take any and all appropriate precautions with regard to electrostatic discharge. Also be aware that the products herein may not be regulatory compliant or agency certified (FCC, UL, CE, etc.).

No License is granted under any patent right or other intellectual property whatsoever. **LTC assumes no liability for applications assistance, customer product design, software performance, or infringement of patents or any other intellectual property rights of any kind.**

LTC currently services a variety of customers for products around the world, and therefore this transaction **is not exclusive**.

Please read the DEMO BOARD manual prior to handling the product. Persons handling this product must have electronics training and observe good laboratory practice standards. **Common sense is encouraged.**

This notice contains important safety information about temperatures and voltages. For further safety concerns, please contact a LTC application engineer.

Mailing Address:

Linear Technology
1630 McCarthy Blvd.
Milpitas, CA 95035

Copyright © 2004, Linear Technology Corporation