

5-A *SwitchMax* Power Transistors

High-Voltage N-P-N Types for Off-Line Power Supplies and Other High-Voltage Switching Applications

Features:

- High-temperature parameters guaranteed
- Fast switching speed
- High voltage ratings:
 $V_{CEX} = 350\text{ V to }450\text{ V}$
- Low $V_{CE(sat)}$ at $I_C = 5\text{ A}$
- VERSAWATT package

Applications:

- Off-line power supplies
- High-voltage inverters
- Switching regulators

T-35-19

TERMINAL DESIGNATIONS

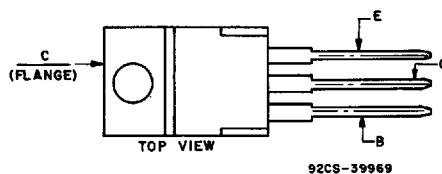

JEDEC TO-220AB

The 2N6738, 2N6739, and 2N6740* SwitchMax series of silicon n-p-n power transistors feature high-voltage capability, fast switching speeds, and low saturation voltages, together with high safe-operating-area (SOA) ratings. They are specially designed for off-line power supplies and are also well suited for use in a wide range of inverter or converter circuits and pulse-width-modulated regulators. These high-voltage, high-speed transistors are 100-per-cent tested for parameters that

are essential to the design of industrial high-power switching circuits. Switching times, including inductive turn-off time, and saturation voltages are guaranteed at 125°C to provide information necessary for worst-case design.

The 2N6738, 2N6739, and 2N6740 series transistors are supplied in the JEDEC TO-220AB package.

*Formerly Dev. Type Nos. TA9141A, TA9141B, and TA9141C, respectively.

MAXIMUM RATINGS, Absolute-Maximum Values:

	2N6738	2N6739	2N6740	
* V_{CEV}				
$V_{BE} = -1.5\text{ V}$	450	550	650	V
* $V_{CEX}(\text{Clamped})$				
$V_{BE} = -1.5\text{ V}$	350	400	450	V
* V_{CEO}	300	350	400	V
* V_{EBO}		8		V
$I_C(\text{sat})$		5		A
* I_C		8		A
I_{CM}		10		A
* I_B		4		A
* P_T				
T_C up to 25°C		100		W
T_C above 25°C, derate linearly		0.8		W/°C
* T_{stg}, T_J		-65 to 150		°C
* T_L				
At distance $\geq 1/8"$ in. (3.17 mm) from seating plane for 10 s max.		235		°C

*In accordance with JEDEC registration data.

CHARACTERISTIC	TEST CONDITIONS				LIMITS						UNITS
	VOLTAGE		CURRENT		2N6738		2N6739		2N6740		
	V dc		A dc		Min.	Max.	Min.	Max.	Min.	Max.	
	V _{CE}	V _{BE}	I _C	I _B							

T-35-19

T_C=25°C

I _{CEV}	450	-1.5			—	0.1	—	—	—	—	mA
	550	-1.5			—	—	—	0.1	—	—	
	650	-1.5			—	—	—	—	—	0.1	
I _{EBO}		-8	0		—	2	—	2	—	2	
V _{CEO(sus)} ^b			0.2 ^a	0	300	—	350	—	400	—	V
h _{FE}	3		5 ^a		10	40	10	40	10	40	
V _{BE(sat)}			5 ^a	1	—	1.6	—	1.6	—	1.6	V
V _{CE(sat)}			5 ^a	1	—	1	—	1	—	1	
			8 ^a	4	—	2	—	2	—	2	
V _{CEX} ^b (Clamped E _{S/b}) L=170 μH, R _{BB} =5 Ω		-5	5	1 ^e	350	—	400	—	450	—	
		-5	8	3 ^e	200	—	250	—	300	—	
I _{S/b}	25		4		0.5	—	0.5	—	0.5	—	s
h _{fe} f=5 MHz	10		0.2		3	12	3	12	3	12	
f _T	10		0.2		15	60	15	60	15	60	MHz
C _{obo} f=0.1 MHz	10 ^c				50	300	50	300	50	300	pF
t _d ^d			5	1	—	0.1	—	0.1	—	0.1	μs
t _r ^d			5	1	—	0.5	—	0.5	—	0.5	
t _s ^d			5	1 ^e	—	2.5	—	2.5	—	2.5	
t _f ^d			5	1 ^e	—	0.4	—	0.4	—	0.4	
t _c V _{CC} =125 V L=170 μH R _C =25 Ω Collector clamped to V _{CEX}			5	1 ^e	—	0.4	—	0.4	—	0.4	

T_C=125°C

I _{CEV}	450	-1.5			—	1	—	—	—	—	mA
	550	-1.5			—	—	—	1	—	—	
	650	-1.5			—	—	—	—	—	1	
V _{CE(sat)}			5 ^a	1	—	2	—	2	—	2	V
t _r ^d			5	1	—	0.8	—	0.8	—	0.8	μs
t _s ^d			5	1 ^e	—	4	—	4	—	4	
t _f ^d			5	1 ^e	—	0.8	—	0.8	—	0.8	
t _c V _{CC} =125 V, L=170 μH, R _C =25 Ω Collector clamped to V _{CEX}			5	1 ^e	—	0.8	—	0.8	—	0.8	

R _{θJC}	10	5			—	1.25	—	1.25	—	1.25	°C/W
R _{θJA}					—	70	—	70	—	70	°C/W

* In accordance with JEDEC registration data

^cV_{CB} value.^eI_{B1} = -I_{B2}^aPulsed, pulse duration = 300 μs, duty factor ≤ 2%^dV_{CC} = 125 V, t_p = 20 μs^bCAUTION The sustaining voltage V_{CEO(sus)}and V_{CEX} MUST NOT be measured on a curve tracer

HARRIS SEMICONDUCTOR 56E D 430227J 0040639 350 HAS

POWER TRANSISTORS

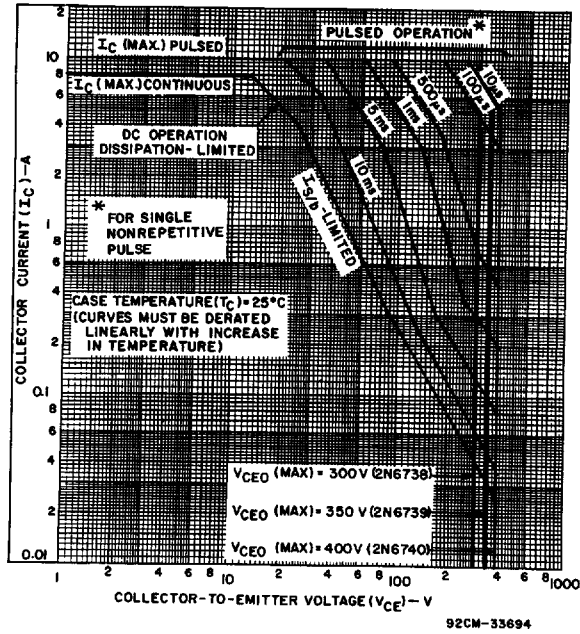

Fig. 1 — Maximum operating areas for all types ($T_c = 25^\circ C$).

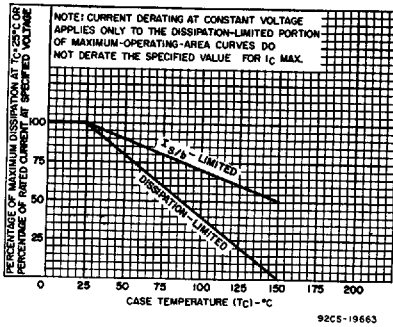

Fig. 2 — Dissipation and derating curve for all types.

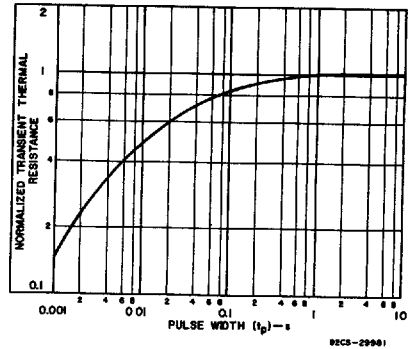

Fig. 3 — Typical thermal-response characteristic for all types.

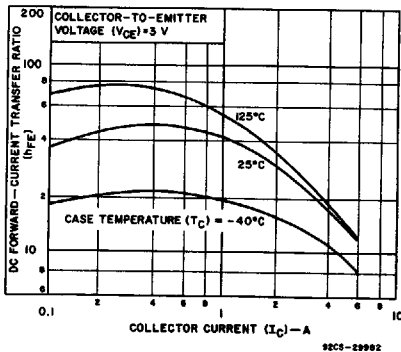

Fig. 4 — Typical dc beta characteristics for all types.

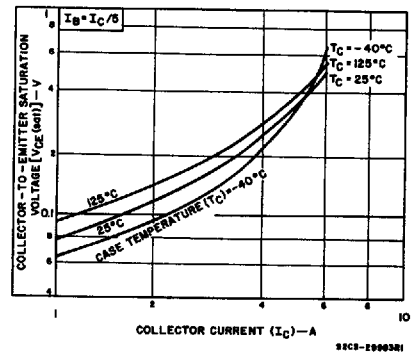

Fig. 5 — Typical collector-to-emitter saturation voltage as a function of collector current for all types.

56E D 430227J 0040640 072 HAS

HARRIS SEMICONDUCTOR

HARRIS SEMICOND SECTOR

T-35-19

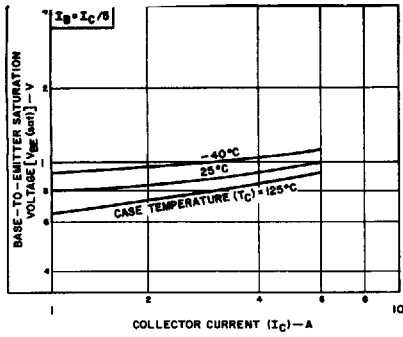

Fig. 6 — Typical base-to-emitter saturation voltage as a function of collector current for all types.

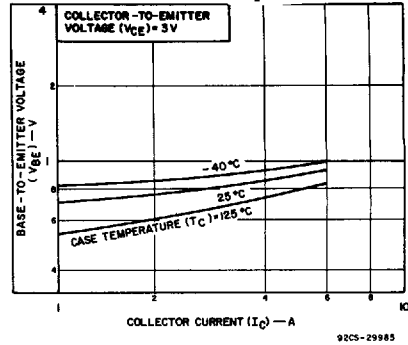

Fig. 7 — Typical base-to-emitter voltage as a function of collector current for all types.

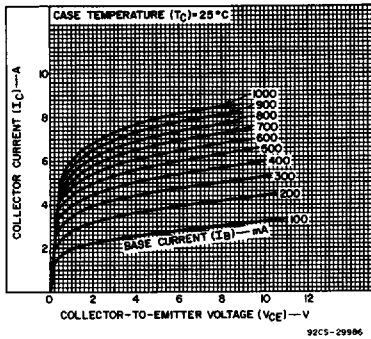

Fig. 8 — Typical output characteristics for all types.

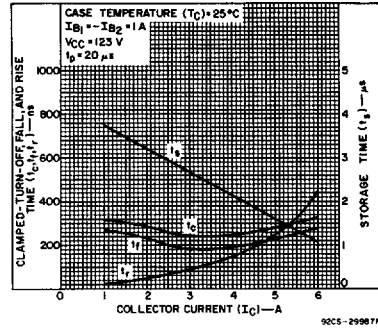

Fig. 9 — Typical saturated switching time characteristics for all types.

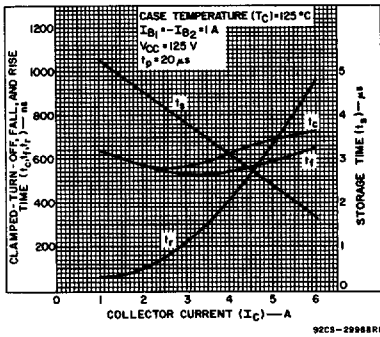

Fig. 10 — Typical saturated switching time characteristics for all types.

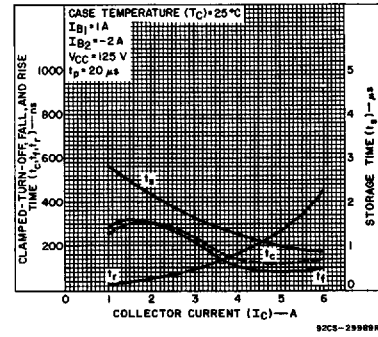

Fig. 11 — Typical saturated switching time characteristics for all types.

POWER TRANSISTORS

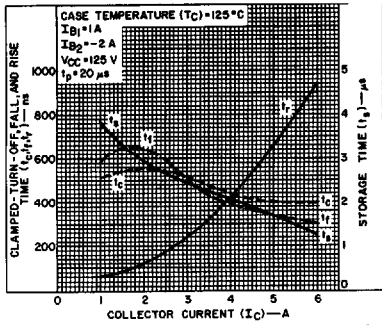

Fig. 12 — Typical saturated switching time characteristics for all types.

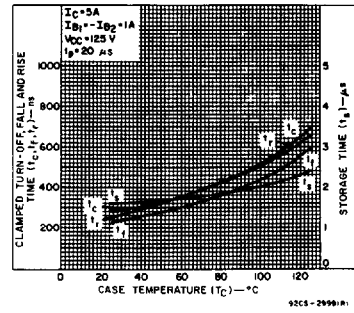

Fig. 13 — Typical saturated switching time characteristics as a function of case temperature for all types.

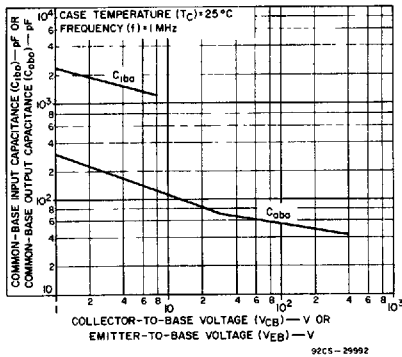

Fig. 14 — Typical common-base input or output capacitance characteristics as a function of collector-to-base voltage or emitter-to-base voltage for all types.

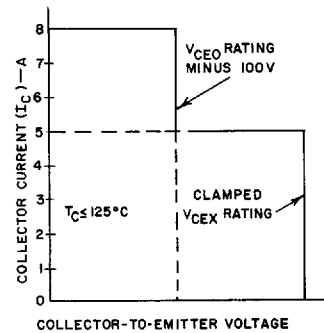

Fig. 15 — Maximum operating conditions for switching between saturation and cutoff.

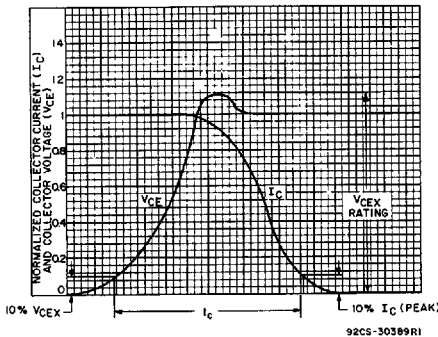

Fig. 16 — Oscilloscope display for measurement of clamped induction switching-time (t_c).

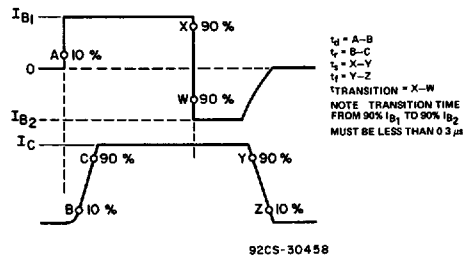

Fig. 17 — Phase relationship between input and output currents showing reference points for specification of switching times.

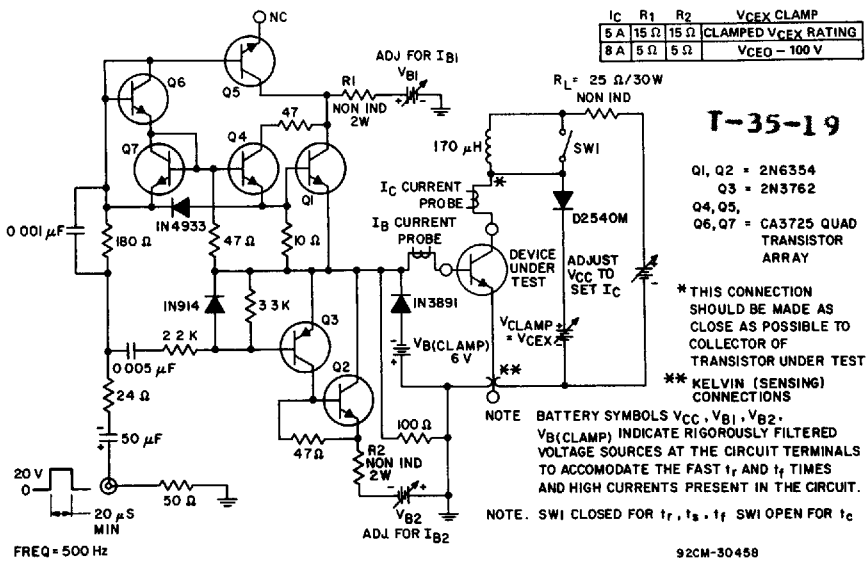

Fig. 18 — Circuit for measuring switching times.

POWER TRANSISTORS