

PRODUCT DATA DRAWING

REVISION HISTORY			
REV	DESCRIPTION	DATE	APPROVED
01	PRELIMINARY	08/12	STW
-	REL. NRN 37890	12/30/12	STW
A	DCN 40984	12/14	STW

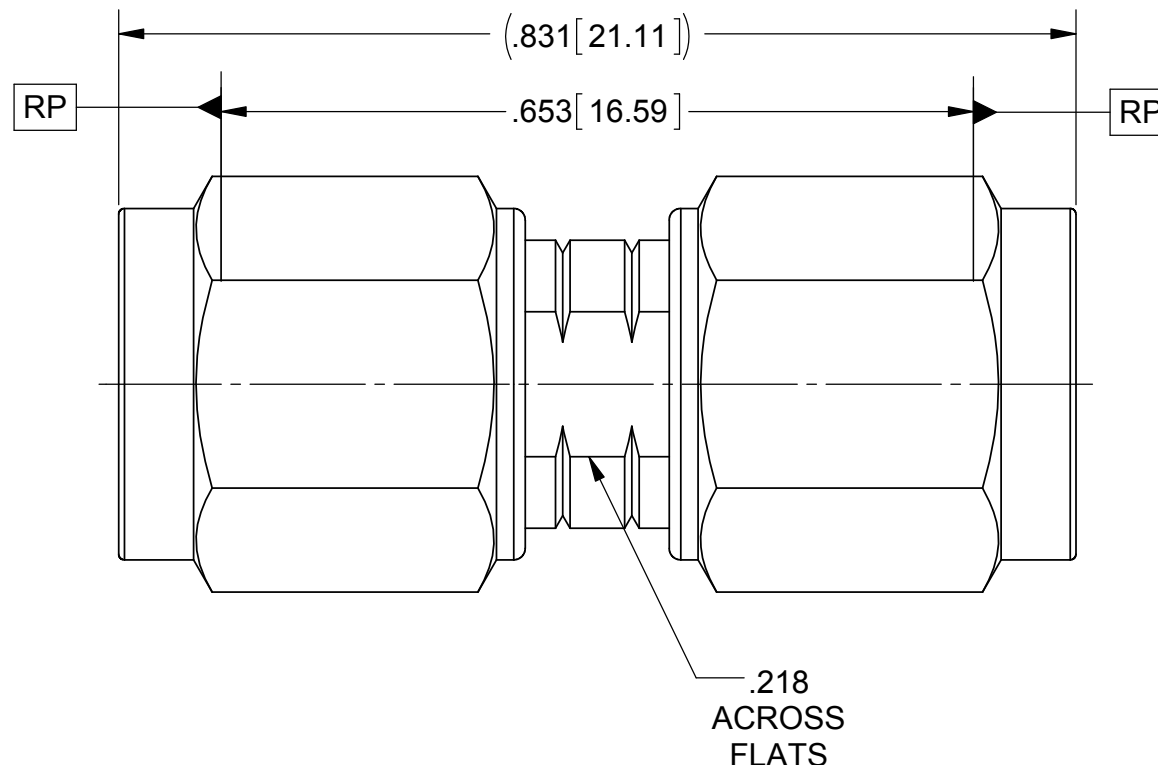
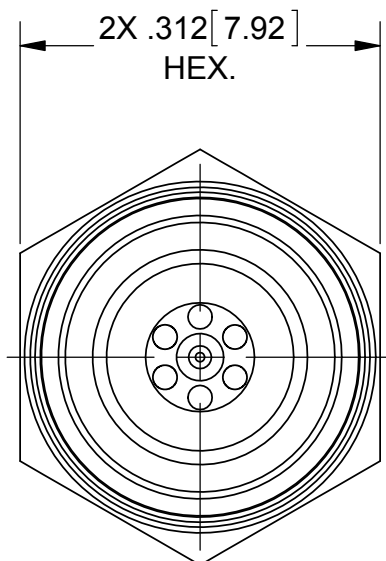

MATERIAL:

BODY, INSERTS & COUPLING NUT:

STAINLESS STEEL PER AMS-5640, ALLOY UNS S30300, TYPE 1

LOCK RING & CONTACT:

BERYLLIUM COPPER PER ASTM B196, ALLOY No. UNS C17300, TD04

BEADS:

POLYETHERIMIDE "ULTEM" PER ASTM D5205

GASKET:

SILICONE RUBBER PER A-A-59588, CLASS 2B, GRADE 50/60

FINISH:

BODY, INSERTS, & COUPLING NUT:

PASSIVATED PER AMS-2700.

CONTACT:

GOLD PER ASTM B488, TYPE II, CODE C, CLASS 1.27, OVER NICKEL PER AMS-QQ-N-290, CLASS 1, .00005" MIN.

PERFORMANCE:

IMPEDANCE:
FREQ. RANGE:
VSWR:

50 OHMS
DC TO 50.0 GHz
1.11:1 MAX. DC TO 18GHz
1.13:1 MAX. 18 TO 26.5 GHz
1.29:1 MAX. 26.5 TO 50 GHz

INSERTION LOSS:

.07 X SQRT (F(F IN GHz))

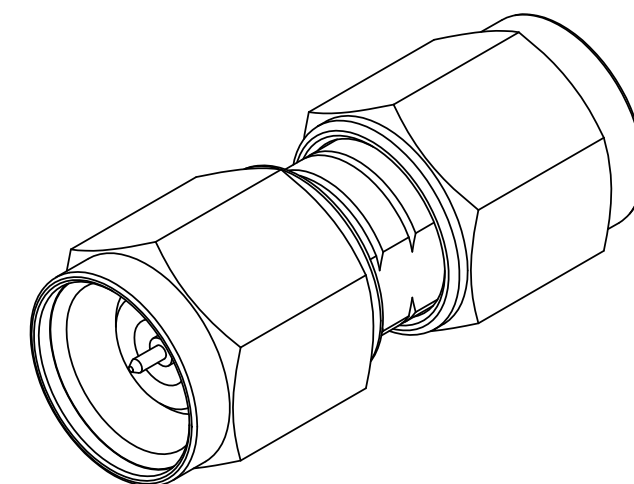

MATERIAL: SEE NOTES	DIMENSIONS ARE IN INCHES TOLERANCES: FRACTIONAL: ±1/64 ANGULAR: X° ±1'0" X"X' ±15'	UNLESS OTHERWISE SPECIFIED 1) ALL DIMENSIONS ARE IN INCHES (MILLIMETERS) 2) ALL DIMENSIONS ARE AFTER PLATING. 3) BREAK CORNERS & EDGES .005 R. MAX. 4) CHAM. 1ST & LAST THREADS. 5) SURFACE ROUGHNESS 63-MIL-STD-10. 6) DIA. 'S ON COMMON CENTERS TO BE CONCENTRIC WITHIN .005 T.I.R. 7) REMOVE ALL BURRS	SV Microwave, Inc. 2400 Centrepark West Drive, Suite 100 West Palm Beach, FL 33409
FINISH: SEE NOTES	DECIMAL: X ±.030 .XX ±.010 .XXX ±.005	INTERPRET DIMENSIONS AND TOLERANCES PER ASME Y14.5M - 1994	TITLE: 2.4mm PLUG TO PLUG ADAPTER
SURFACE AREA: N/A	THIRD ANGLE PROJECTION	DRAWN: ELA 08/10/12	SIZE: B CAGE CODE: 95077 DWG. NO. SF1116-6039
PROPRIETARY THE INFORMATION CONTAINED IN THIS DRAWING IS THE SOLE PROPERTY OF SV MICROWAVE, INC. ANY REPRODUCTION IN PART OR AS A WHOLE WITHOUT THE WRITTEN PERMISSION OF SV MICROWAVE, INC IS PROHIBITED.		CHECKED: STW 08/10/12 APPROVED: STW 08/10/12	SCALE: 6:1 SHEET 1 OF 1