

1. MECHANICAL DIMENSIONS :

REV.	DATE	DESCRIPTION
01	Jan. 15, '18	1st RELEASE

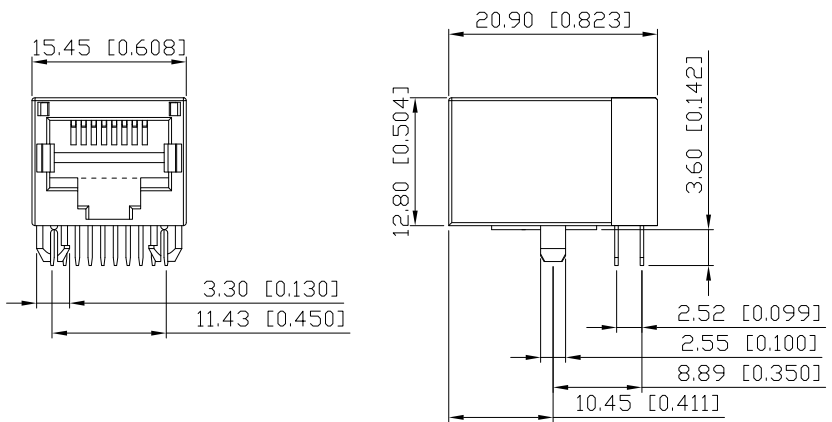

NOTES:

- MATERIAL:
HOUSING: HIGH THERMOPLASTIC, UL94V-0, BLACK
CONTACTS: T=0.35mm PHOS-BRONZE,
GOLD FLASH AND TIN IN SOLDER AREA
- OPERATING TEMPERATURE: -40°C~+85°C
- INSERTION FORCE: 4 POUNDS MAX.
EXTRACTION FORCE: 4 POUNDS MAX.
- DURABILITY: 750 MATING CYCLED MIN.
- CAVITY CONFORMS TO FCC RULES AND REGULATIONS PART 68,
SUBPART F.
- UNSPECIFIED TOLERANCE: .XX ±0.25[0.010]
.X ±0.30[0.012]

RECOMMENDED PLUG DIMENSION:

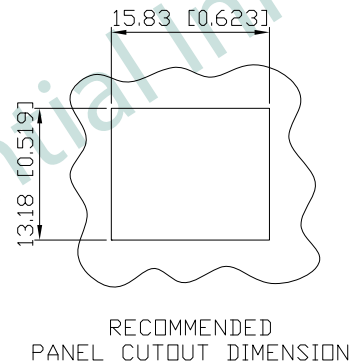
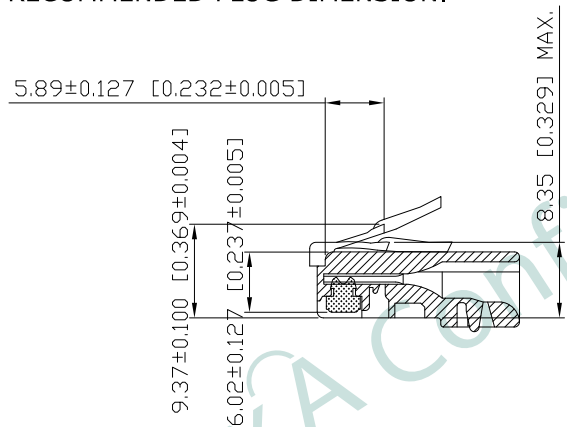

PART NO		KPF-01P-0-PA3-000		
TITLE	RJ45 8P8C, W/ 10/100 TRANSFORMER AND PoE, W/D LED, UNSHIELDED			
REV : 01				
UNIT	DRAWN	CHKD	DATE	SHEET
mm[inch]	CINDY	DANIEL	Jan. 15, '18	1 of 4

ROHS Compliant

2. PCB LAYOUT :

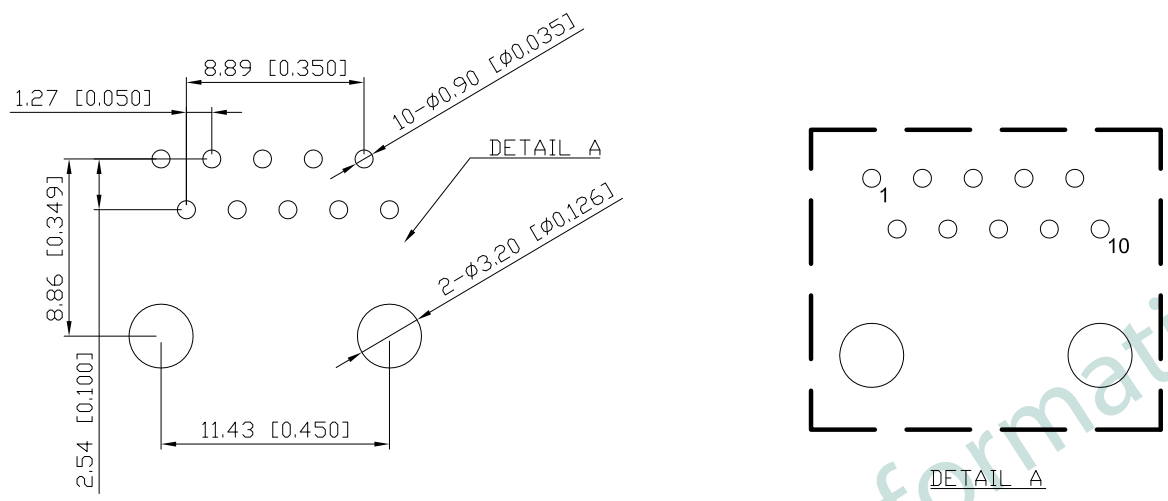

P#	DEFINITION
P1	-
P2	TD+
P3	TD-
P4	CT
P5	-
P6	-
P7	-
P8	RD+
P9	RD-
P10	-

SUGGESTED PCB LAYOUT
(TOP VIEW) SCALE:2:1
DIMENSIONAL TOLERANCE: .XX ±0.08[0.003]

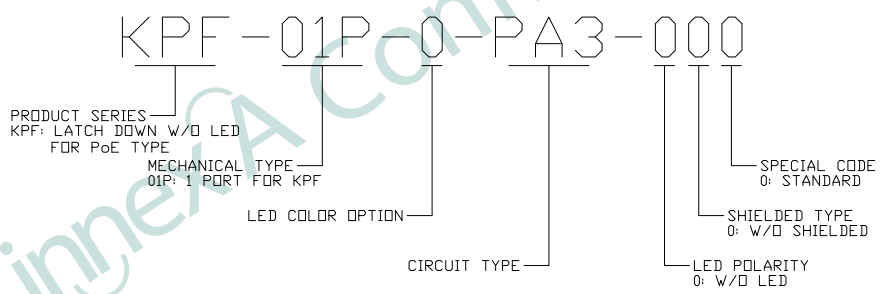

PART NO		KPF-01P-0-PA3-000		
TITLE	RJ45 8P8C, W/ 10/100 TRANSFORMER AND PoE, W/D LED, UNSHIELDED			
REV : 01				
UNIT	DRAWN	CHKD	DATE	SHEET
mm[inch]	CINDY	DANIEL	Jan. 15, '18	2 of 4

3. SCHEMATIC :

4. ELECTRICAL CHARACTERISTICS :

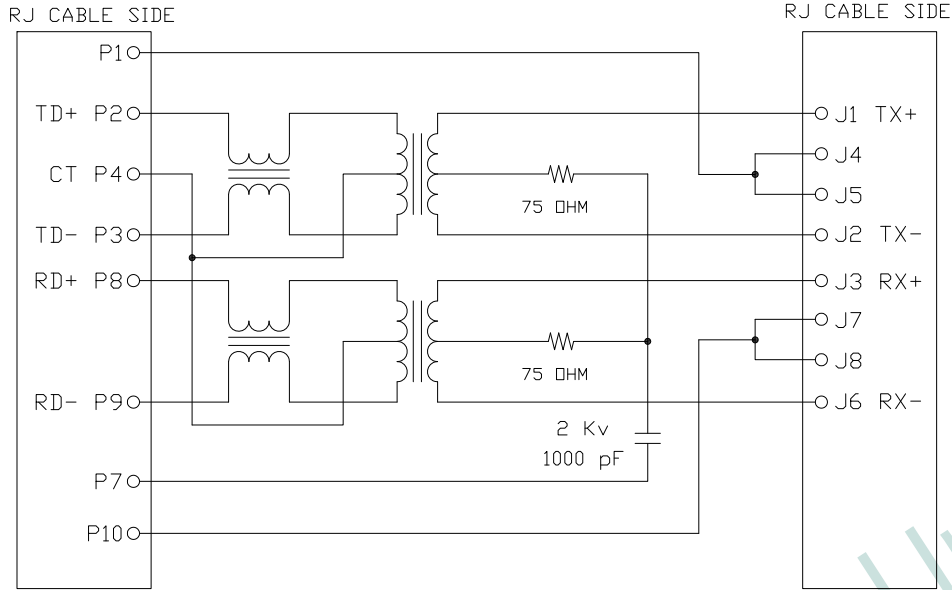

TEST NOTES:(25±5°C)

1. TR:
INPUT TO OUTPUT=1:1±3%
2. LX:(100KHz,100mV,8mA, DC Bias)
350uH MINIMUM
3. DCR:
EVERY RJ PAIR=1.2 Ω MAXIMUM
4. HIPOT:
INPUT(RJ SIDE) TO OUTPUT(LAN SIDE):
1500 VAC/60SEC
5. INSERTION LOSS:
-1.0dB MAXIMUM AT 0.3MHz TO 100MHz
6. RETURN LOSS:
-20dB MINIMUM AT 1MHz TO 30MHz
-15dB MINIMUM AT 30MHz TO 60MHz
-10dB MINIMUM AT 60MHz TO 80MHz
7. CROSS TALK:
-30dB MINIMUM AT 1MHz TO 100MHz
8. COMMON TO COMMON MODE REJECTION:
-30dB MINIMUM AT 1MHz TO 100MHz
9. WORKING CURRENT FOR PoE: 360mA DC MAX

 PART NO		KPF-01P-0-PA3-000		
TITLE	RJ45 8P8C, W/ 10/100 TRANSFORMER AND PoE, W/O LED, UNSHIELDED			
REV : 01				
UNIT	DRAWN	CHKD	DATE	SHEET
mm[inch]	CINDY	DANIEL	Jan. 15, '18	3 of 4

5. PROFILE OF WAVE SOLDER :

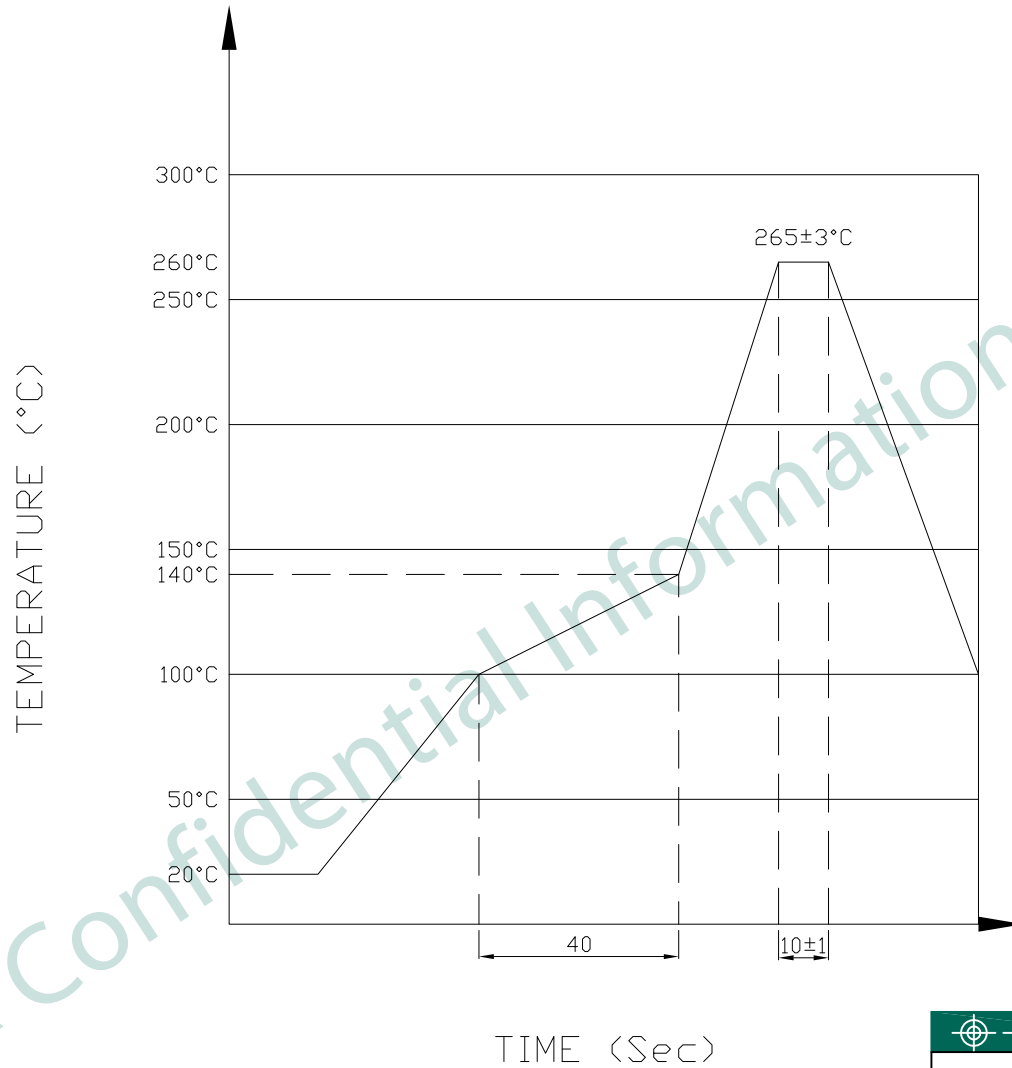

The measuring point for the specified temperature shall be on the soldered part of the lead

PART NO KPF-01P-0-PA3-000				
TITLE	RJ45 8P8C, W/ 10/100 TRANSFORMER AND PoE, W/D LED, UNSHIELDED			
REV : 01				
UNIT	DRAWN	CHKD	DATE	SHEET
mm[inch]	CINDY	DANIEL	Jan. 15, '18	4 of 4