



### Electrical specifications

**Center Frequency:** 8016 MHz  
**Passband:** 7656-8376 MHz  
**Insertion loss over passband:** <1.0 dB  
**Passband flatness:** +/- 0.2 dB  
**Return loss over passband:** >14 dB  
**Rejection 1:** >80 dB@6960 MHz  
**Rejection 2:** >80 dB@8960 MHz

### Mechanical

**Mounting Method:** Threaded Mounting Holes  
**Connector Type:** SMA Female  
**Dimensions:** 2.75" x 0.50" x 0.50" in

### Environmental

**Operating Temperature:** -45 to +85° C  
**Storage Temperature:** -55 to +95° C  
**Shock:** 20 G. 11ms  
**Vibration:** 20 G. 5 to 200 MHz

### Outline Drawing:

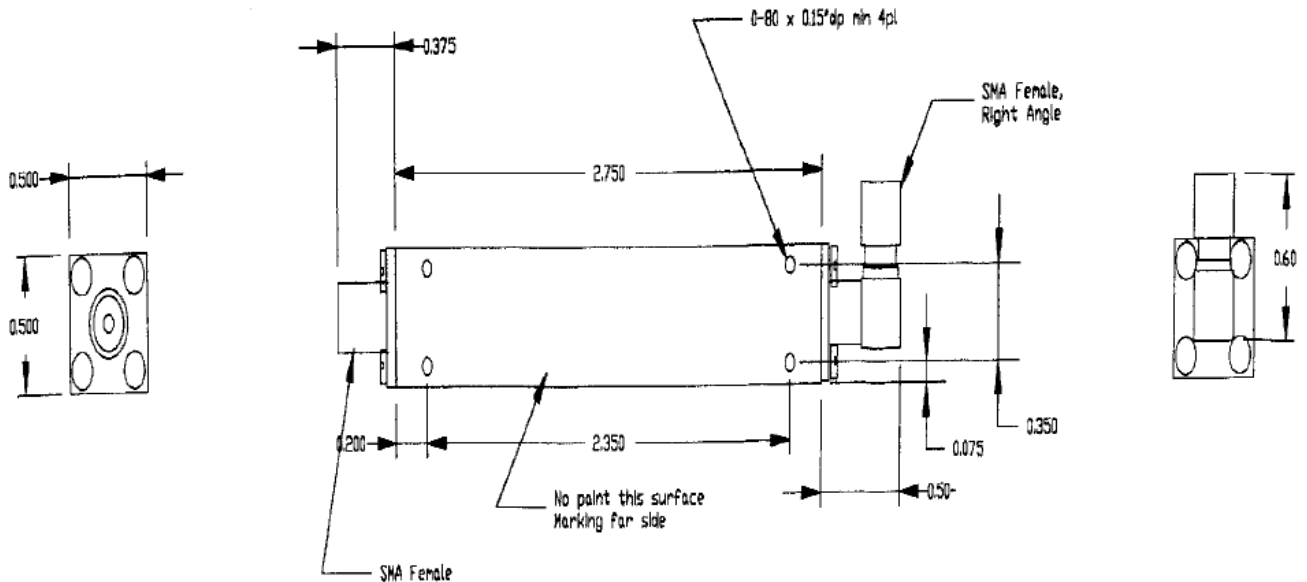



**ANATECH ELECTRONICS INC**  
RF & Microwave Filters & Products

# 8016 MHz Cavity Bandpass Filter

Part Number: AB8016B871



## Plots:

